

Stack-Lift

390966 – 390968 - 391900

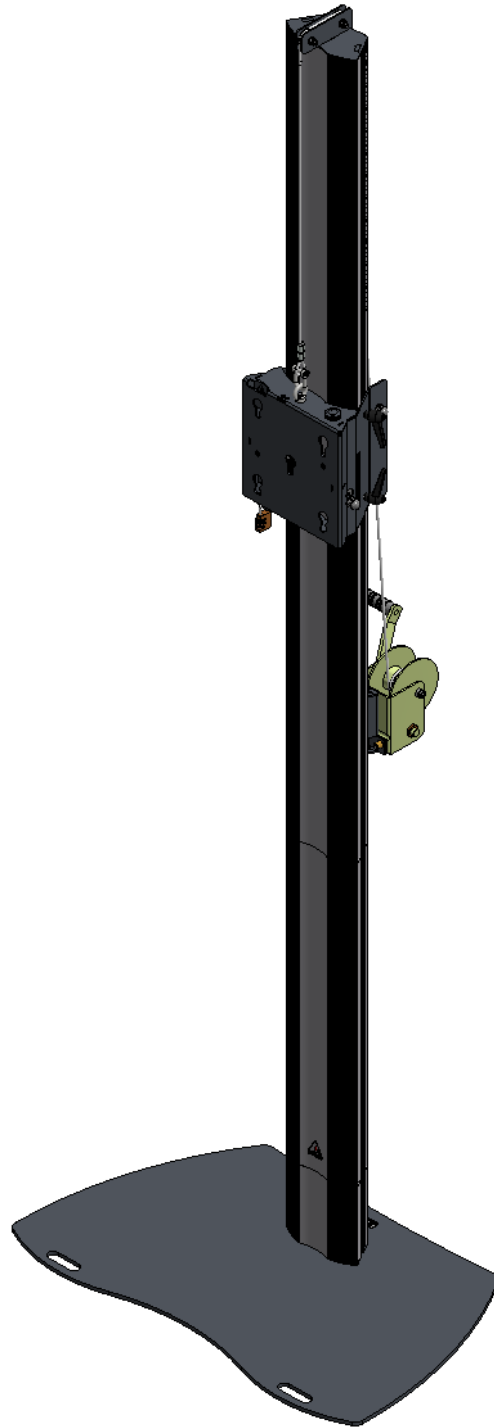

 **Audipack**[®]
It's great to have solutions...

1.
Install the Stack-Lift only on level floors!

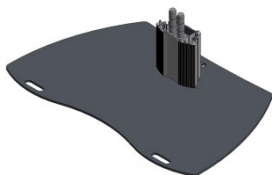

2.
Place the floor plate
on the floor

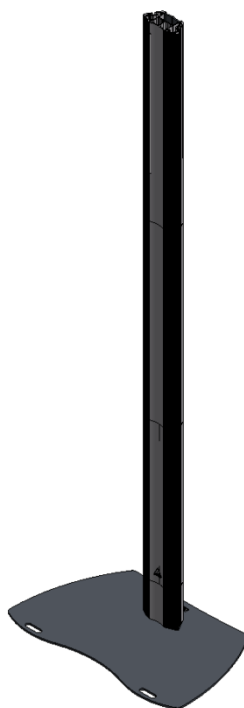

3.
Stack the columns
on the floor plate
and on each other.



4.
Slide on the
mounting head.



5.
Secure the columns to each
other with the clips and to the
floor plate.

6.
Place the cable guidance on top of the column. Lock it with the butterfly bolts.

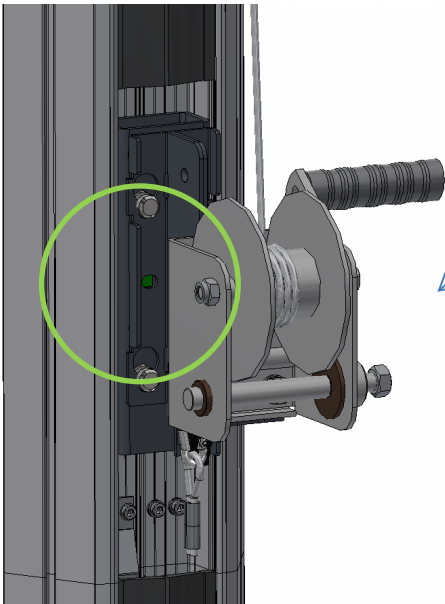
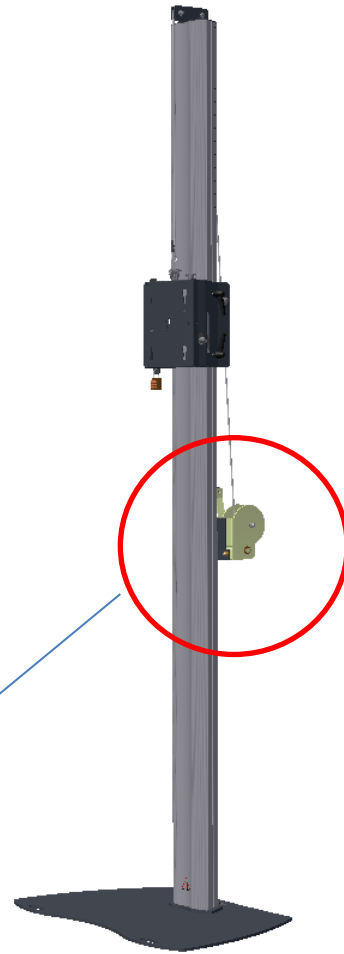
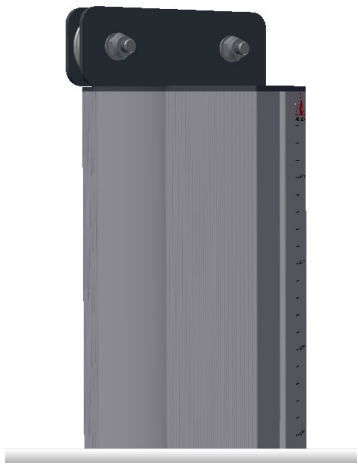

7.
Install the hoist to the back of the Stack-Lift by inserting it in the cams.
Secure it well with the *safety cable* and check for the **green check spot**.

Use all 4 cams.

Loop the cable across the upper cable guidance.

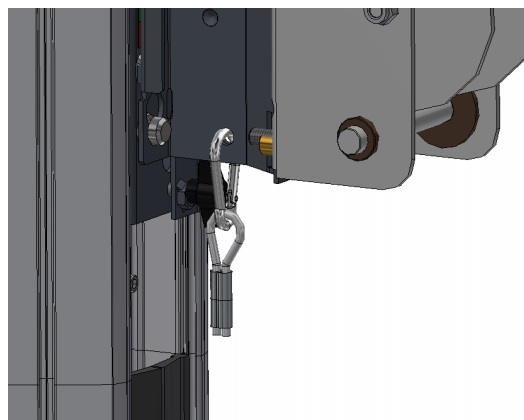
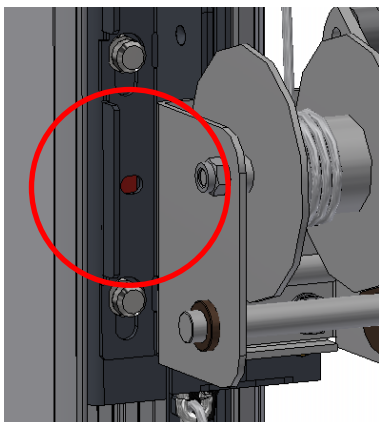

8.

Install the monitor with an Audipack monitor mount and hoist up the screen to presentation height.

Lock the position of the mounting head when ready.

9.

The Stack-Lift requires an obligated safety test and check every year.

10.

Annual product check.

Yearly the product needs to be checked. It is possible to have the hoist and cable be checked at a local company or deliver the product to Audipack.

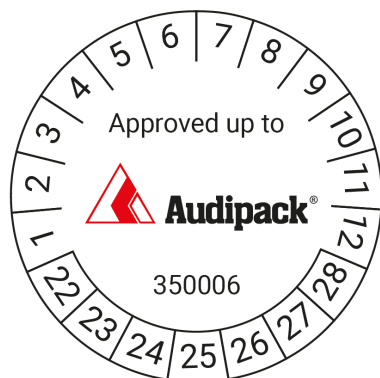

Important product information

This product is suitable for a determined max. load, see the product label for more.
The product is only suitable for lifting screens and monitors, connected / installed with proper certified / original Audipack materials.

User manual:

- Assemble the product according the supplied manual and place the product only on flat surfaces, with sufficient grip. The surface must be level.
- Secure all dividable items with the provided fasteners.
- Check stability and safety of the product.
- The load must be suspended level and equal to the product, always level!
- Make sure the hoist cable is organized neatly on the cable drum, do not bend the cable, organize next to each other. Do not cross the cable on the drum.
- Always leave 2-3 complete windings left on the drum.

Safety rules:

- The user must be trained and informed about the legal working conditions act, wearing personal safety clothes, shoes etc. Extra attention not to walk below the load.
- Do not install a ladder / scaffolding against the product.
- A load may never swing or be out of balance. At an offset position of the load, re-install the product.
- Check before every use the product on damage, function, wear and tear on cable or missing parts, check the cable, function + safety and anti-slip feet.
- When (cable)fault are detected do not use the product and contact Audipack
- The product must be checked every year by an expert on lifting devices; this for the safety of the user and surrounding persons.

NEN-EN-ISO 12100:2010NL

Slijtende delen vallen niet onder garantie:

- Staalkabel
- Staalkabelhulzen
- Hijshaak

Parts excluded from product warranty:

- Lifting cable / steel cable
- Kabel fixantions
- Lifting hook

Audipack's general conditions of sales and delivery apply to all of Audipack's deliveries. These conditions can be downloaded from Audipack's website, www.audipack.com, or will be sent by post on request.

Audipack liefert ausschließlich unter die allgemeine Verkauf- und Lieferungsbedingungen von Audipack. Diese Bedingungen sind zum downloaden verfügbar auf die Webseite von Audipack, www.audipack.com, oder werden Ihnen auf Anfrage per Post gesendet.

Alle leveringen geschieden uitsluitend volgens de Algemene Verkoop- en Leveringsvoorwaarden van Audipack. Een afschrift hiervan kunt u downloaden van de website van Audipack, www.audipack.com, of wordt u op aanvraag gestuurd per post.

Les conditions de vente et de livraison de Audipack s'appliquent à tous les livraisons de Audipack. Cette conditions sont disponible sur le site internet de Audipack, www.audipack.com, où seront envoyé par poste sur demande.

AUDIPACK

Industriestraat 2-4
2751 GT Moerkapelle
the Netherlands

Tel: +31(0)795931671
Fax: +31(0)795933115
Email: audipack@audipack.com

www.audipack.com

Audipack reserves the right to make changes in specifications and other information contained in this document without prior written notice. The information provided herein is subject to change without notice. In no event shall Audipack be liable for any incidental, special, indirect, or consequential damages whatsoever, including but not limited to lost profits, arising out of or related to this manual or the information contained herein, even if Audipack has been advised of, known, or should have known, the possibility of such damages.