

OWM90

WALL ENCLOSURE FOR OUTDOOR DISPLAYS

FOR SAMSUNG 46" LH46OHB MONITOR



OWM90 outdoor wall enclosure is an innovative solution, designed and dedicated to Samsung LH46OHB monitor. A solid, metal structure and a modern look of the device guarantee high quality. The internal ventilation system and easy access to installation and maintenance services make it very popular.

FEATURES

- Durable steel construction
- Integrated cable management system
- Place for IT equipment
- Quick and easy assembly

PRODUCT SPECIFICATIONS

Short index	OWM90
Product group	Wall enclosures
Category	Wall enclosures for outdoor displays
Colour	Black
Warranty	Limited 5-years
Number of screens	1
Screen size	46"
Maximum load	50 kg



46"



50 kg



Durable steel construction



Quick and easy assembly

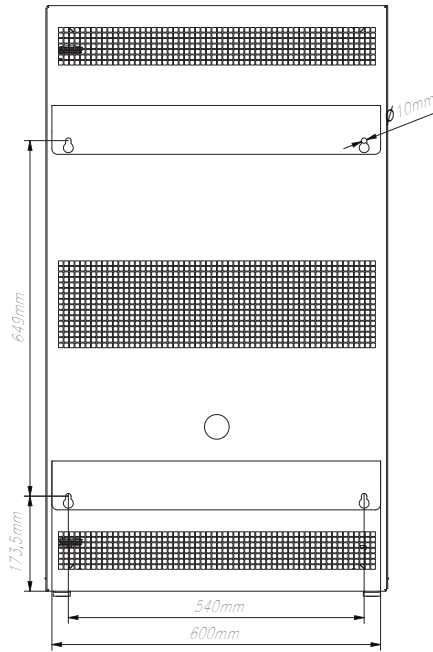
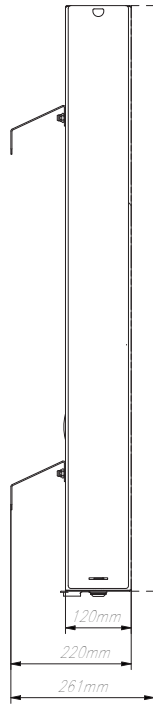
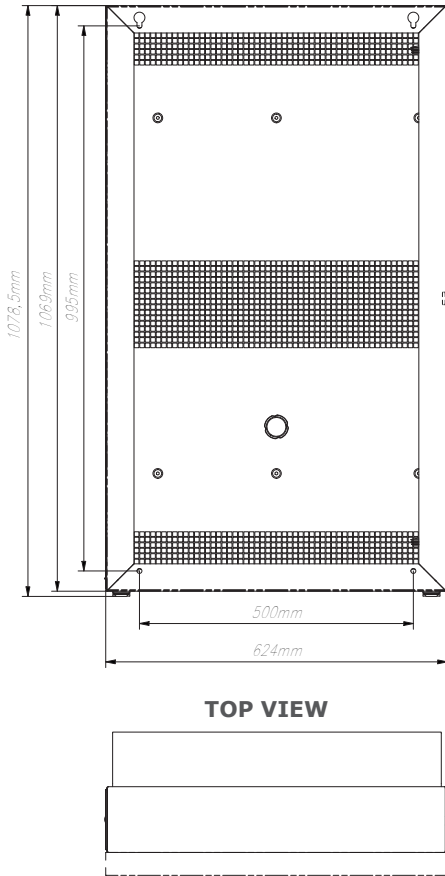
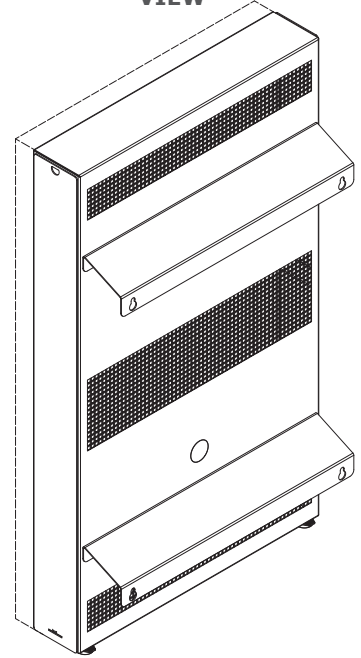

Wall mounting

FRONT VIEW
SIDE VIEW
REAR VIEW

ISOMETRIC VIEW

TECHNICAL SPECIFICATIONS

Product dimensions

W: 624 mm D: 220 mm H: 1078,5 mm (W:24,57" D:8,66" H:42,46")

Product weight

19 kg (41,88 lb)

LOGISTICS DATA

SAP INDEX	EAN CODE	COLOUR	PACKAGE DIMENSIONS	PACKAGE WEIGHT
WOZE-OWM90	5902841106727	BLACK	1088 x 634 x 230 mm 42,83 x 24,96 x 9,05"	19,5 kg 43 lb

HS Code (Harmonized System): 732690, HTS Code (Harmonized Tariff Schedule): 7326909890, Country of Origin: Poland

ACCESSORIES AND RELATED PRODUCTS

OWM101



POK100

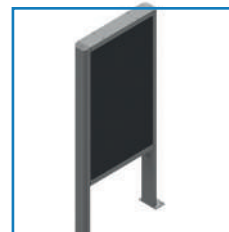

POK101