

SD/HD/3G-SDI 1 to 8 Distribution Amplifier & Repeater

Operating Instruction

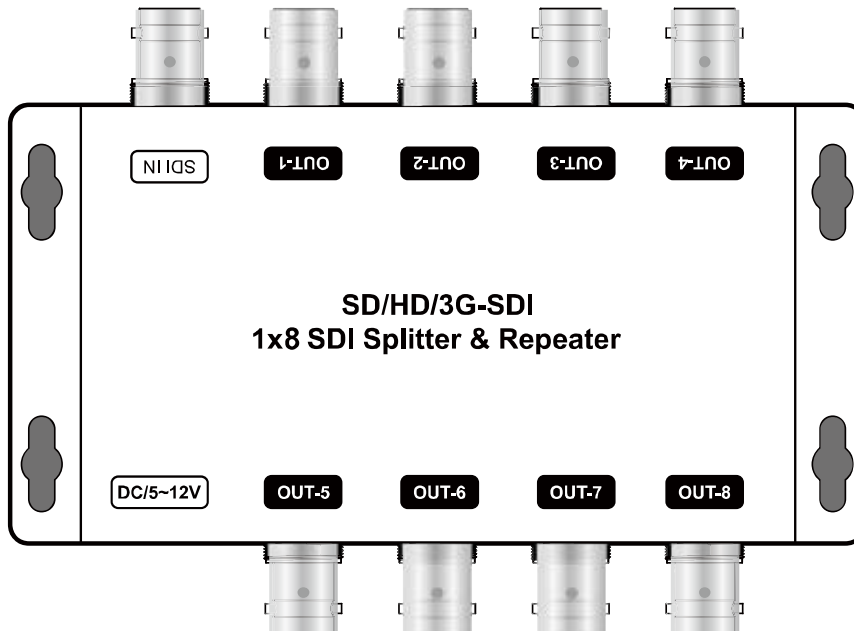

Dear Customer

Thank you for purchasing this product. For optimum performance and safety, please read these instructions carefully before connecting, operating or adjusting this product. Please keep this manual for future reference.

Features

- 1) Distributes 1 SDI input to 8 SDI outputs simultaneously
- 2) Single unit can transmit up to 120m/390ft (Belden 1694A)
- 3) Re-clocking function capability---unlimited repeater connection
- 4) Support SDI Standard :SD-SDI,HD-SDI, 3G-SDI
- 5) Data Rates: 270Mbps(SD-SDI), 1.485Gbps (HD-SDI), 2.97Gbps (3G-SDI)
- 6) Signal Type: SMPTE 292M, SMPTE 259M, SMPTE 424M
- 7) DC 5V1A (Power consumption less than 2W)
- 8) With mounting ears

NOTICE

Our company reserves the right to make changes in the hardware, packaging and any accompanying documentation without prior written notice.

Specifications

Re-clocking Function	Yes
SDI Standards	SD-SDI, HD-SDI,3G-SDI
HD/SD-SDI Detection	Auto
Supported Protocols	SMPTE 259M SMPTE 292M SMPTE 424M
Data Rates	270Mbps(SD-SDI), 1.485Gbps (HD-SDI), 2.97Gbps (3G-SDI)
Video Support	480i@60hz, 720p@50/59.94/60hz, 1080i@50/59.94/60hz, 1080p@23.98/24/25/29.97/30/50/59.94/60hz
SDI Signal Type	SMPTE-292M, SMPTE-259M, SMPTE-424M
Output Impedance	75 ohms
Cable Equalization	HD-SDI up to 120m SD-SDI up to 200m Unlimited repeater connection
Audio Sampling rate	48Khz
Impedance	75 ohms
Input	1x BNC [SDI]
Output	8x BNC [SDI]
Power Adapter	5V1A DC
Power Consumption(Max)	2W
Dimension(LxWxH)	L115xW64xH30mm
Operating Temperature	0°C ~ 40°C / 32°F ~ 104°F
Storage Temperature	-20°C ~ 60°C / -4°F ~ 140°F
Relative Humidity	20~90% RH (no condensation)
Housing Material	Metal case

Package Contents

- 1x8 Splitter & Repeater
- 5V1A DC power adaptor
- User Manual

PANEL DESCRIPTIONS

Left Side View

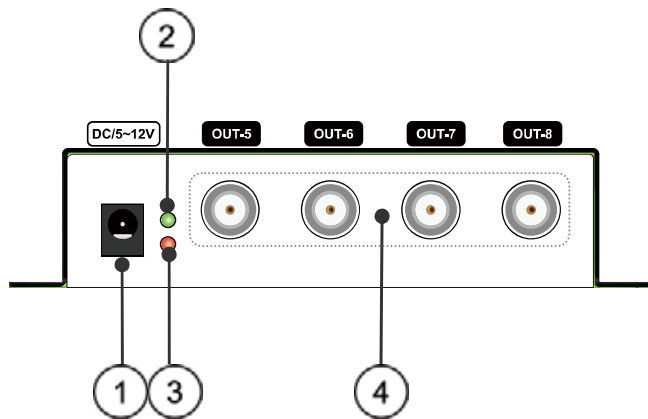

Right Side View

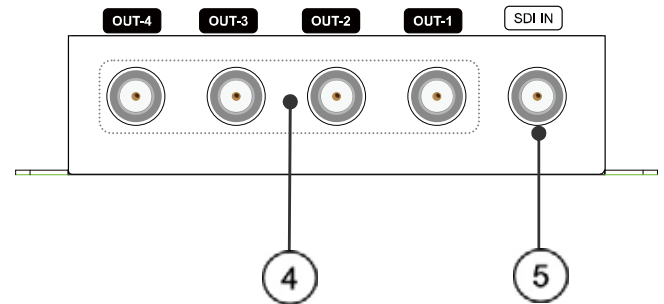

- 1) DC 5~12V
- 2) Green indicator of source status
- 3) Red indicator of power input
- 4) SDI outputs
- 5) SDI input

Connecting and Operating

1. Connect a camera or other device equipped with SDI output to 1x8 SDI repeater input.
2. Connect devices equipped with SDI input (e.g monitors or video processors) to the 1x8 SDI repeater outputs.
3. Plug power adapter into power jack.



Note 1) This item can also work with our HDMI to SDI converter and SDI to HDMI converter.

2) We suggest you use cable with Belden 1694A.

3) The distance depends on the quality of the SDI signal from the HD Camera source and also the coax cable & connector.

Typical Application

(1) Distribute one SDI input to 8 SDI output

Coaxial cable (RG59) —————

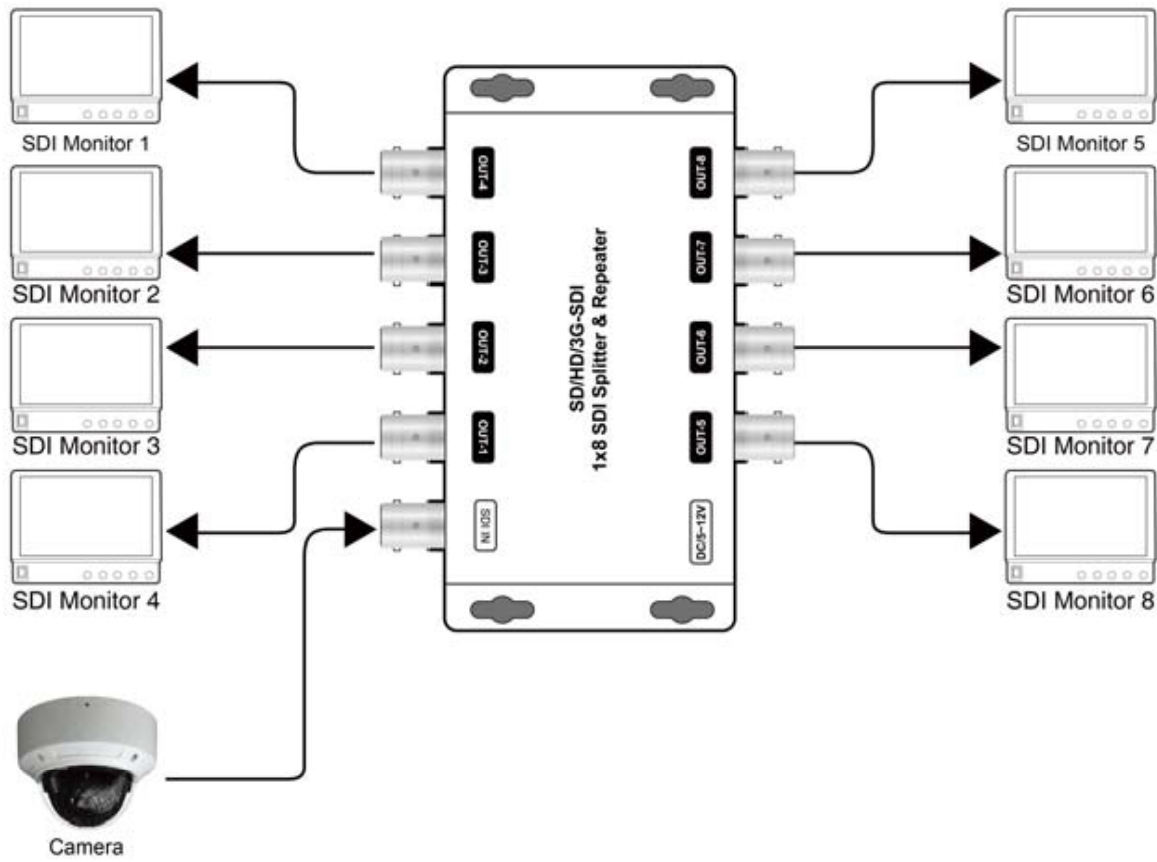

(2) Connect with HDMI to SDI converter and SDI to HDMI converter

HDMI cable (dotted line)

Coaxial cable (RG59) —————

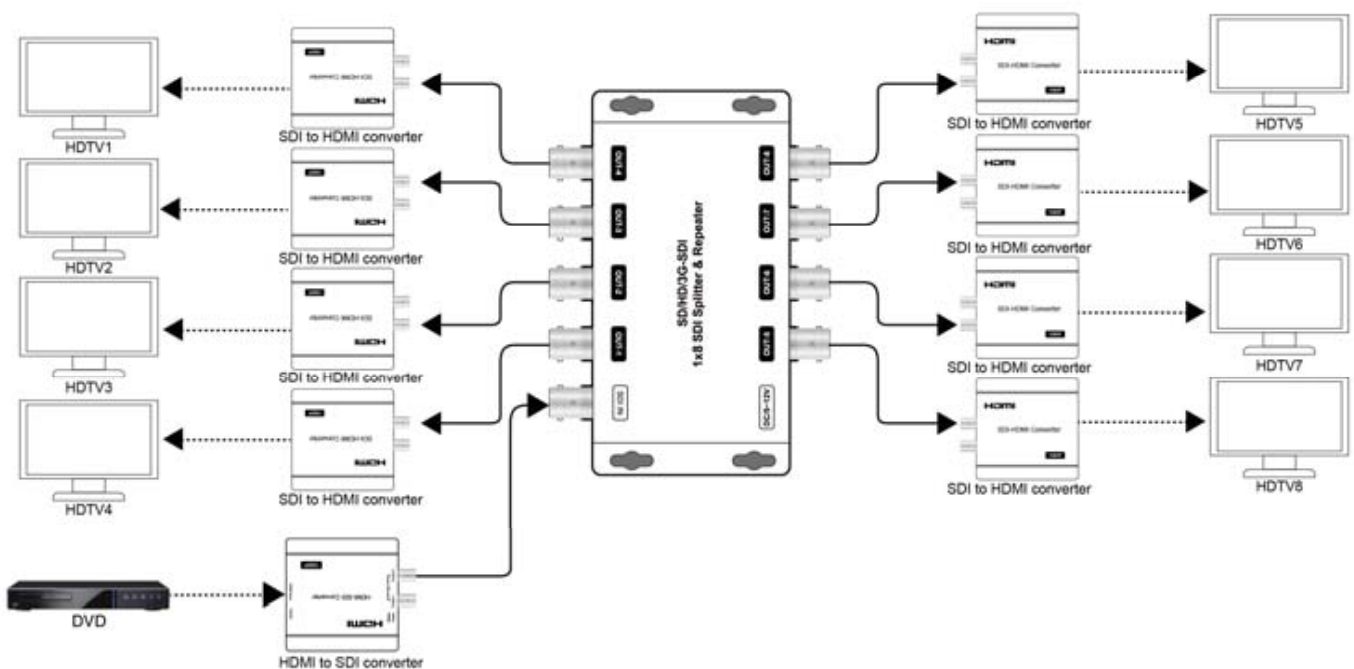

(3) Repeater connection

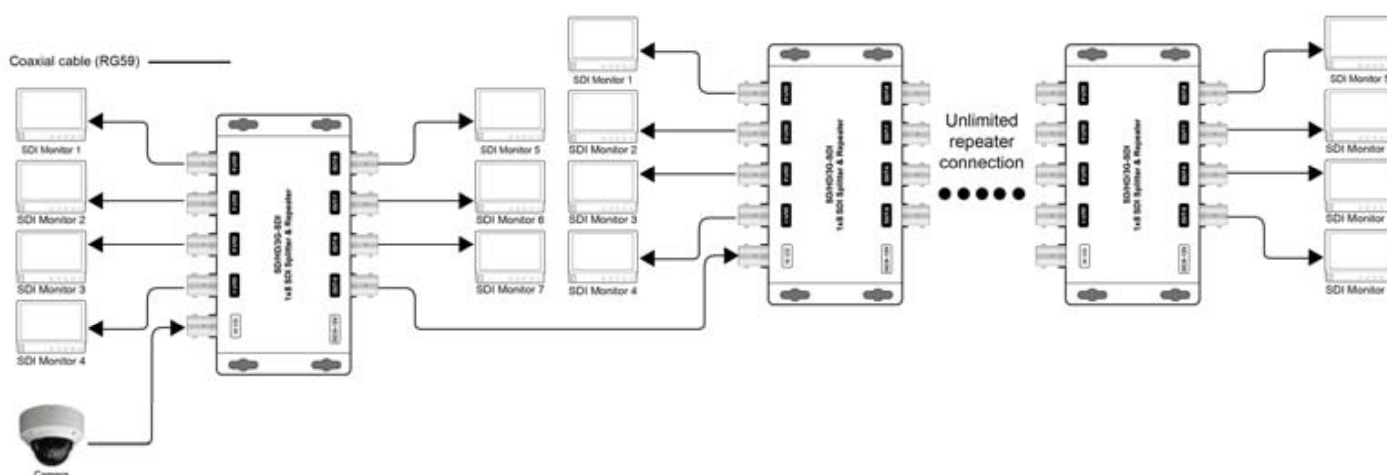

After sale Service and Warranty

WARRANTY

If your product does not work properly because of a defect in materials or workmanship, our Company (referred to as "the warrantor") will, for the length of the period indicated as below, **(Parts(2)Year, Labor(90) Days)** which starts with the date of original purchase ("Limited Warranty period"), at its option either(a) repair your product with new or refurbished parts, or (b) replace it with a new of a refurbished product. The decision to repair or replace will be made by the warrantor.

During the "Labor" Limited Warranty period there will be no charge for labor.

During the "Parts" warranty period, there will be no charge for parts. You must mail-in your product during the warranty period. This Limited Warranty is extended only to the original purchaser and only covers product purchased as new. A purchase receipt or other proof of original purchase date is required for Limited Warranty service.

MAIL-IN SERVICE

When shipping the unit carefully pack and send it prepaid, adequately insured and preferably in the original carton. Include a letter detailing the complaint and provide a day time phone and/or email address where you can be reached.

LIMITED WARRANTY LIMITS AND EXCLUSIONS

(a) This Limited Warranty ONLY COVERS failures due to defects in materials or workmanship, and DOES NOT COVER normal wear and tear or cosmetic damage. The failures which are caused by products not supplied by warrantor, or failures which result from accidents, misuse, abuse, neglect, mishandling, misapplication, alteration, faulty installation, set-up adjustments, maladjustment of consumer controls, improper maintenance, power line surge, lightning damage, modification, or service by anyone other than a Factory Service center or other Authorized Server, or damage that is attributable to acts of God.

(b) THERE ARE NO EXPRESS WARRANTIES EXCEPT AS LISTED UNDER "LIMITED WARRANTY COVERAGE". THE WARRANTOR IS NOT LIABLE FOR INCIDENTAL OR CONSEQUENTIAL DAMAGES RESULTING FROM THE USE OF THIS PRODUCT, OR ARISING OUT OF ANY BREACH OF THIS WARRANTY. (As examples, this excludes damages for lost time, cost of having someone remove or re-install an installed unit if applicable, travel to and from the service, loss of or damage to media or images, data or other recorded content. The items listed are not exclusive, but are for illustration only.)

(c) PARTS AND SERVICE, WHICH ARE NOT COVERED BY THIS LIMITED WARRANTY, ARE YOUR RESPONSIBILITY.