

MBV1155-L

MENU BOARD CEILING MOUNT

FOR ONE 42"-57" SCREEN, LANDSCAPE

MBV1155-L is a robust and accurately manufactured ceiling screen mount. It features a slim structure and simple design. Stepwise height adjustment ensures accurate fastening, and the integrated cable management system allows the cabling to be hidden, guaranteeing aesthetic appearance. Equipped with safety devices that protect the screen against falling, it is perfect for hotels, restaurants and public buildings. The MBV1155-L mount is a perfect solution for those who value aesthetics and comfort during use.

FEATURES

- Screen load-carrying plate made of aluminum
- Stepwise height adjustment
- Quick and simple installation
- Integrated cable management system
- Universal VESA-compliant mounting range

PRODUCT SPECIFICATIONS

Short index	MBV1155-L
Category	Menu Board Ceiling Mounts
Product group	Video Wall & Menu Board Mounts
Colour	Black
Warranty	Limited 5-years
Number of screens	1
Minimum screen size	42"
Maximum screen size	57"
Maximum load	70 kg
Forward tilting	+18°
VESA Mounting Compatibility	100×100 up to 600×400

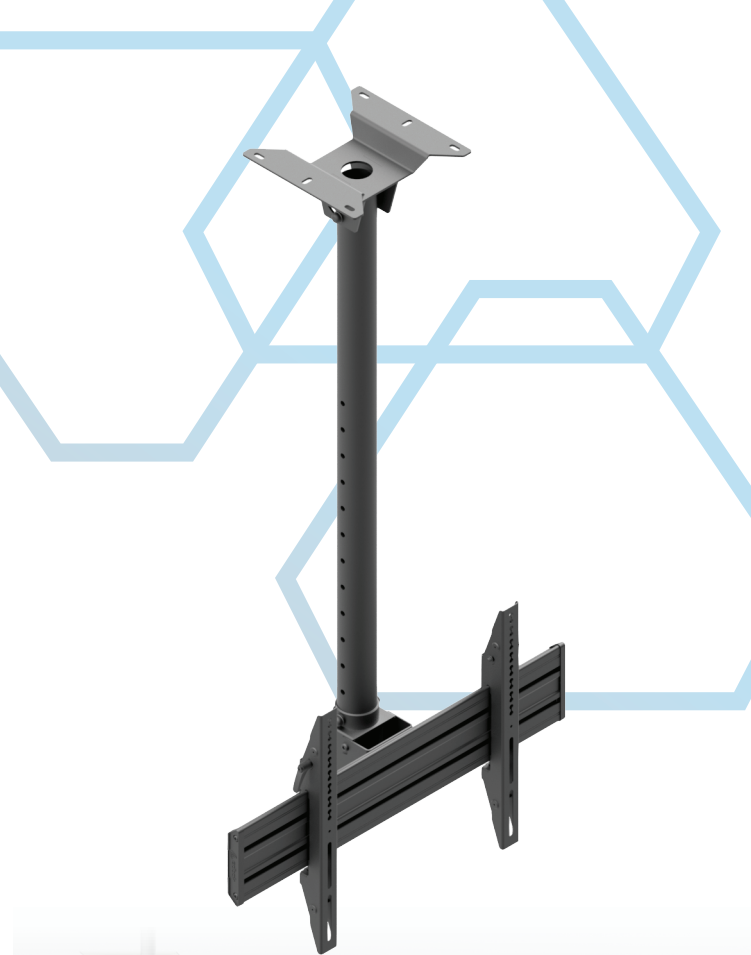

Vertical adjustment

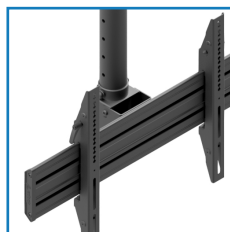

Integrated cable management system

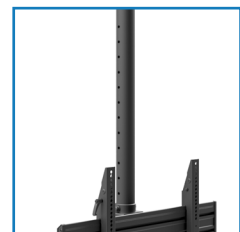

Stepwise height adjustment

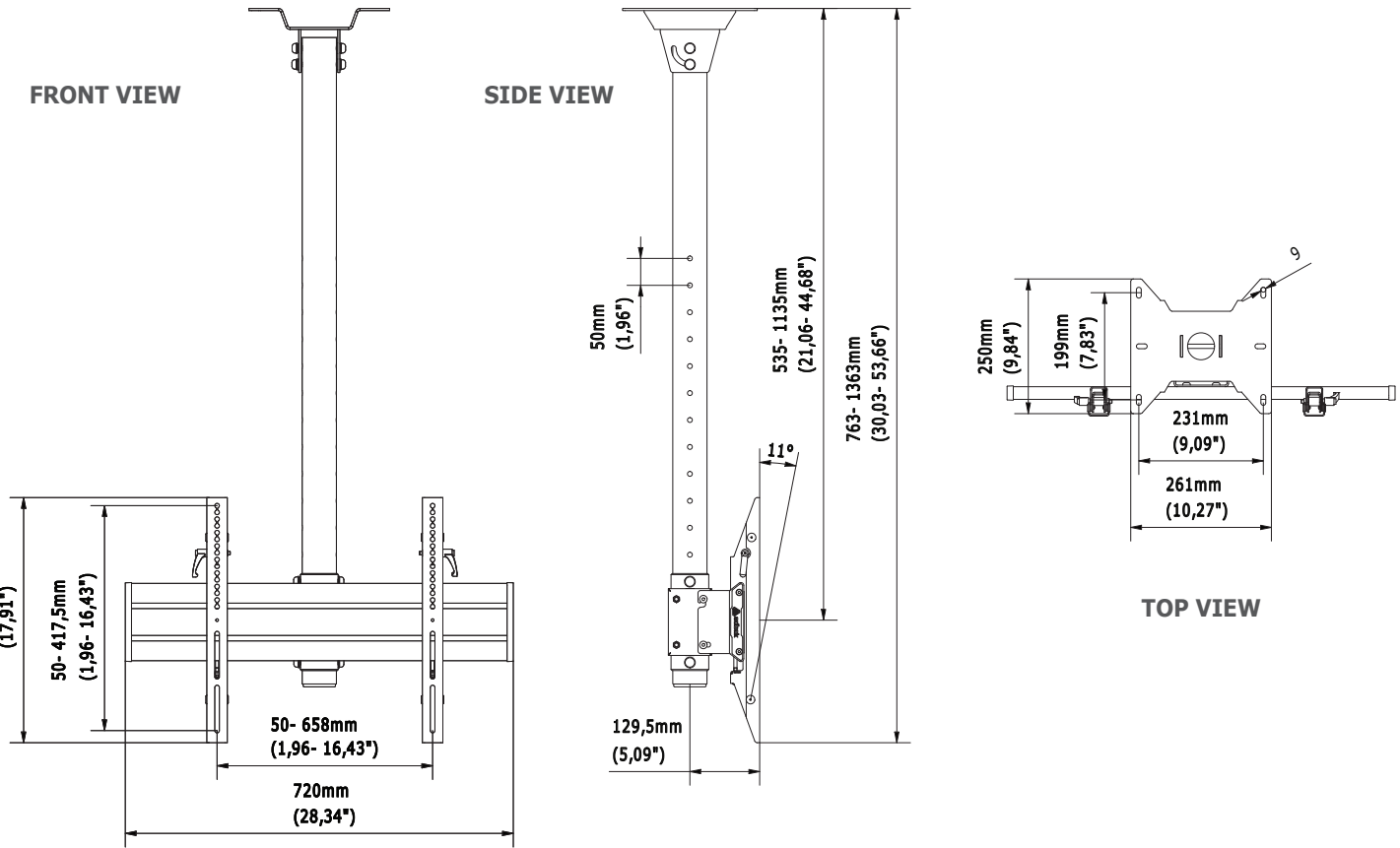

TECHNICAL SPECIFICATIONS

Product dimensions	W: 720 mm D: 250 mm H: 1363 mm (W:28,35" D:9,84" H:53,66")
Product weight	14 kg (31 lb)
Max. distance from mounting surface	1135 mm (44,68")
Min. distance from mounting surface	535 mm (21,06")
Max. mounting pattern	658 mm x 417,5 mm
Min. mounting pattern	50 mm x 50 mm

LOGISTICS DATA

SAP INDEX	EAN CODE	COLOUR	PACKAGE DIMENSIONS	PACKAGE WEIGHT
WUSU-MBV1155-L	5902841112162	BLACK	1310 x 310 x 185 mm 51,57 x 12,20 x 7,28"	15,5 kg 34 lb

HS Code (Harmonized System): 732690, HTS Code (Harmonized Tariff Schedule): 7326909890, Country of Origin: Poland

ACCESSORIES AND RELATED PRODUCTS



MBV1155-P



MBV1155BB-L



MBV2147-L



MBV3147-L