

## Overview

The DHR12 is a 2-way bi-amp powered loudspeaker equipped with a 12-inch woofer and a 1.4-inch HF driver, perfect for use as a main speaker. Combining a 1000W amplifier and high-performance DSP with the same plywood construction found on Yamaha's high-end DZR Series, the DHR12 offers best-in-class sound quality and durability.



## Features

- Featuring a plywood cabinet that delivers a clear sound with minimal vibration
- Plywood enclosure with a polyurea coating for a robust, scratch resistant surface
- Compact size despite the 12-inch LF driver that provides excellent low frequency response
- Dual-angle pole sockets offer both 0° or a -7° down tilt
- Rigging points for use with eye bolts
- Proprietary FIR-X™ tuning, provides FIR filtering and corrective EQ, minimizing phase distortion

## Specifications

### General Specifications

System Type		2-way, Bi-amped Powered Speaker, Bass-reflex
Components	LF	Diameter: 12" cone, Voice Coil: 2.5", Magnet: Ferrite
	HF	Diaphragm: 1.4", Type: 1" throat compression driver, Magnet: Ferrite
Frequency Range (-10dB)		48Hz – 20kHz
Crossover		1.8 kHz: FIR-X tuning™ (linear phase FIR filter)
Coverage Angle (Horizontal x Vertical)		H90° x V60° (Rotatable)
Amplifier Type		Class-D
Power Rating	Dynamic	1,000 W (LF: 800 W, HF: 200 W) *1
	Continuous	465 W (LF: 400 W, HF: 65 W)
Maximum Output Level (Measured Peak, IEC noise@1m)		130 dB SPL
Cooling		Fan cooling, 4 speeds
A/D D/A Converters		24 bit 48 kHz Sampling
Processors		HPF: OFF, 100 Hz, 120 Hz, 24 dB/Oct.; D-CONTOUR: FOH/MAIN, MONITOR, OFF
I/O Connectors		INPUT1: Combo x1, INPUT2: Combo x 1 + RCA pin x 2 (Unbalanced), OUTPUT: XLR3-32 x 1 (CH1 Parallel Through or CH1+CH2 Mix)
Power Consumption		74 W (1/8 power), 18 W (Idle)
Power Requirements		100 V, 110-120 V, 220-240 V, 110/127/220 V (Brazil), 50/60 Hz
Cabinet Mmaterial		Plywood
Finish		Durable Polyurea Painting, Black
Handle		Top x1, Side x2
Pole Socket		Φ35 mm x2 (Bottom, 0° or -7°)
Rigging		Top x 2, Rear x 1 (Fit for M10 x 30 – 50 mm Eyebolts)
Floor Monitor Angle		–
Dimensions (W x H x D) (with rubber feet)		359 mm x 578 mm x 340 mm (14.1" x 22.8" x 13.4")
Net Weight		19.2 kg (42.3 lbs)

\*1 Total peak power of individual outputs (AC 120V, 25°C). This value was measured at minimum load impedance, with protection released.

## Dimensions

Unit: mm (inch)

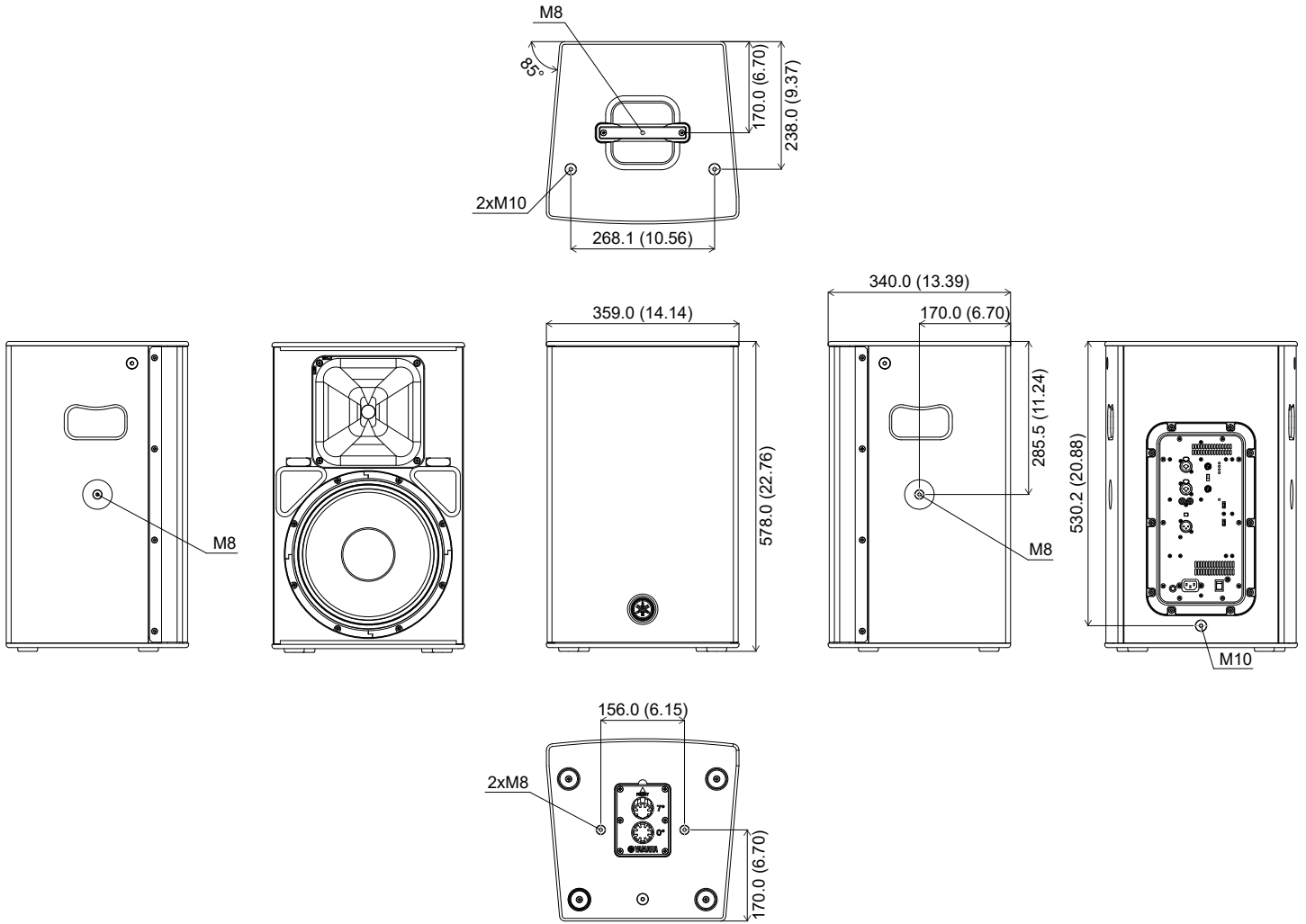

## Options

- U Bracket

UB-DXRDHR12

## Architectural and Engineering Specifications

---

The Yamaha DHR12 Powered Loudspeaker shall be a two-way bass-reflex type full-range loudspeaker system having a single 12" cone driver with a 2.5" voice coil for the low frequencies and a 1.4" compression driver with a 1" throat for the high frequencies. The loudspeaker shall incorporate a class-D amplifier capable of delivering 1000 watts dynamic or 465 watts continuous power. The amplifier section shall include a 4-speed fan for cooling. The DHR12 Powered Loudspeaker shall meet the following performance criteria: Maximum SPL shall be 130dB at 1 meter, frequency response shall be 48Hz to 20kHz at 10dB below rated sensitivity, the frequency dividing network shall have a crossover frequency of 1.8kHz, and the nominal coverage angle shall be 90° horizontal and 60° vertical via a rotatable horn.

Built-in 24-bit 48kHz AD/DA conversion and digital signal processing shall provide FIR-X Tuning (linear phase FIR filters) for smooth crossover and optimum time alignment, plus D-CONTOUR dynamic processing to achieve maximum SPL while maintaining optimum overall response. The D-CONTOUR feature shall include switchable FOH/MAIN and MONITOR modes. A switchable high-pass filter (OFF/100Hz/120Hz) shall also be provided.

Clip limiting, integral power, and DC fault protection shall be provided for the speakers. Thermal and output overcurrent protection shall be provided for the amplifier. Thermal, output overvoltage, and output overcurrent protection shall be provided for the power supply. Power, protection, signal, and limit indicators shall be provided on the rear panel.

Two input channels shall be provided, each with a Combo connector that accepts balanced input via XLR or TRS phone type plugs. Channel 1 shall have a MIC/LINE input selector switch. Channel 2 shall provide an additional pair of RCA pin connectors for unbalanced inputs. Both channels shall have level controls that allow Channel 1 + Channel 2 mixing. One XLR3-32 connector that is switchable for CH1 THRU operation or CH1+CH2 Mix output shall also be provided. The cabinet shall be constructed of wood with a durable black Polyurea coating. The cabinet shall have one top handle and two side handles, threaded mounting points for M10 eyebolts (top x 2, rear x 1), and M8 screw holes for installation of an optional U-bracket for direct ceiling or wall mounting. Two 35mm pole sockets shall be provided, one for normal vertical mounting and one that allows the speaker to be angled downward by 7 degrees. Dimensions shall be 359 (W) x 578 (H) x 340 (D) mm. Weight shall be 19.2kg.

# Block Diagram

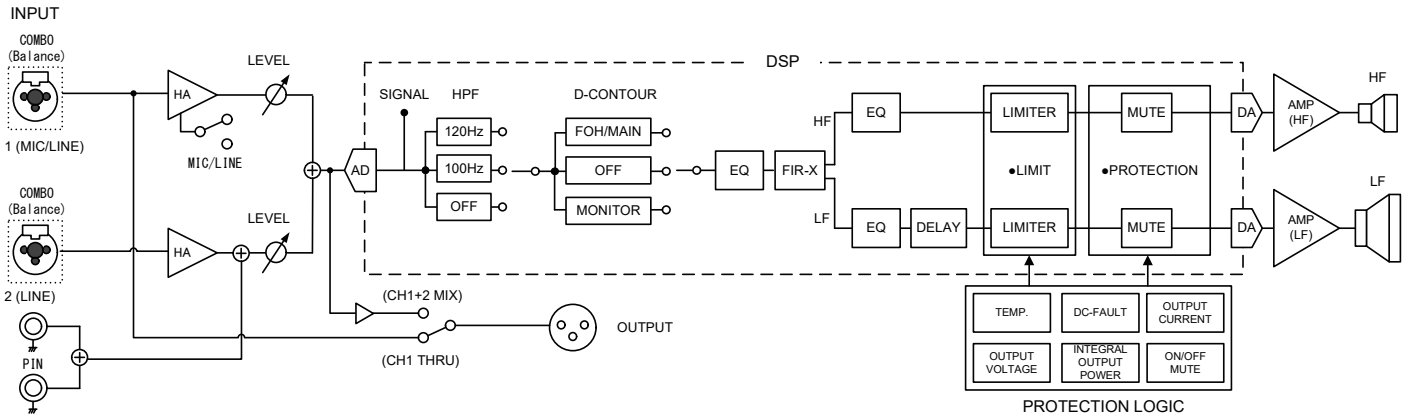

### Frequency Response

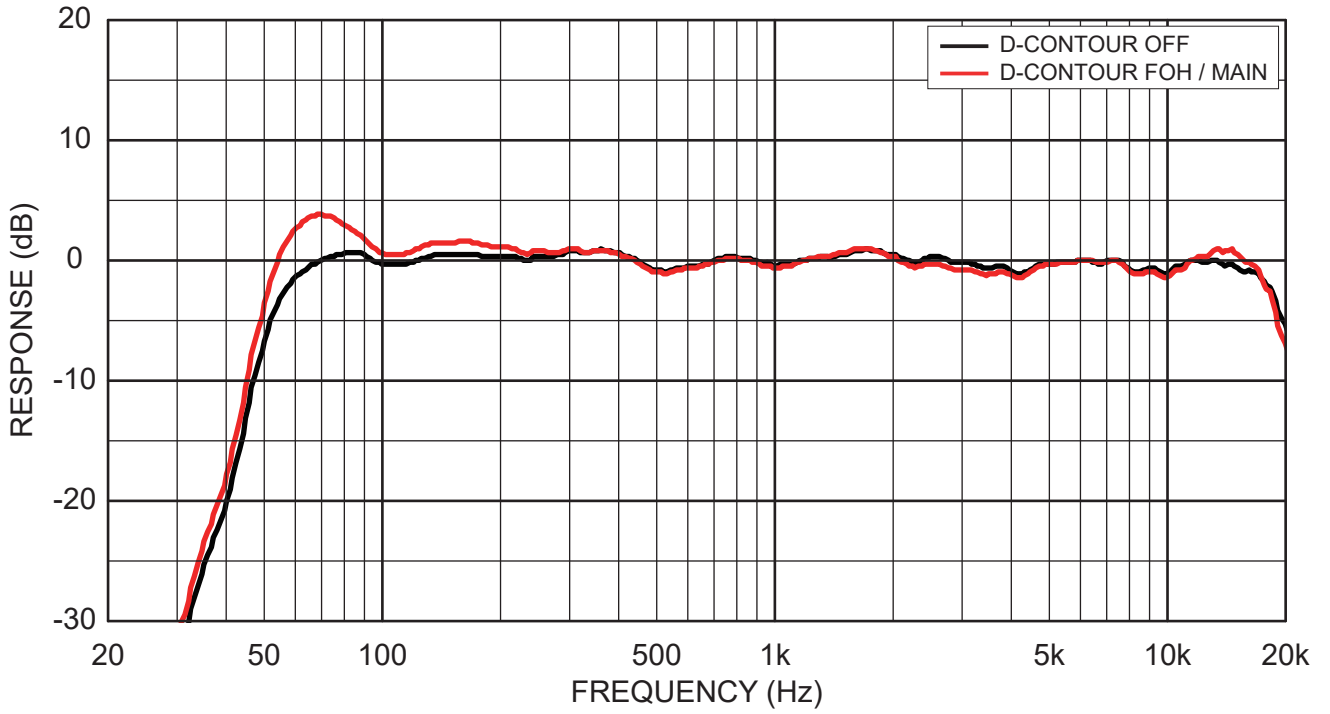

### Phase Response

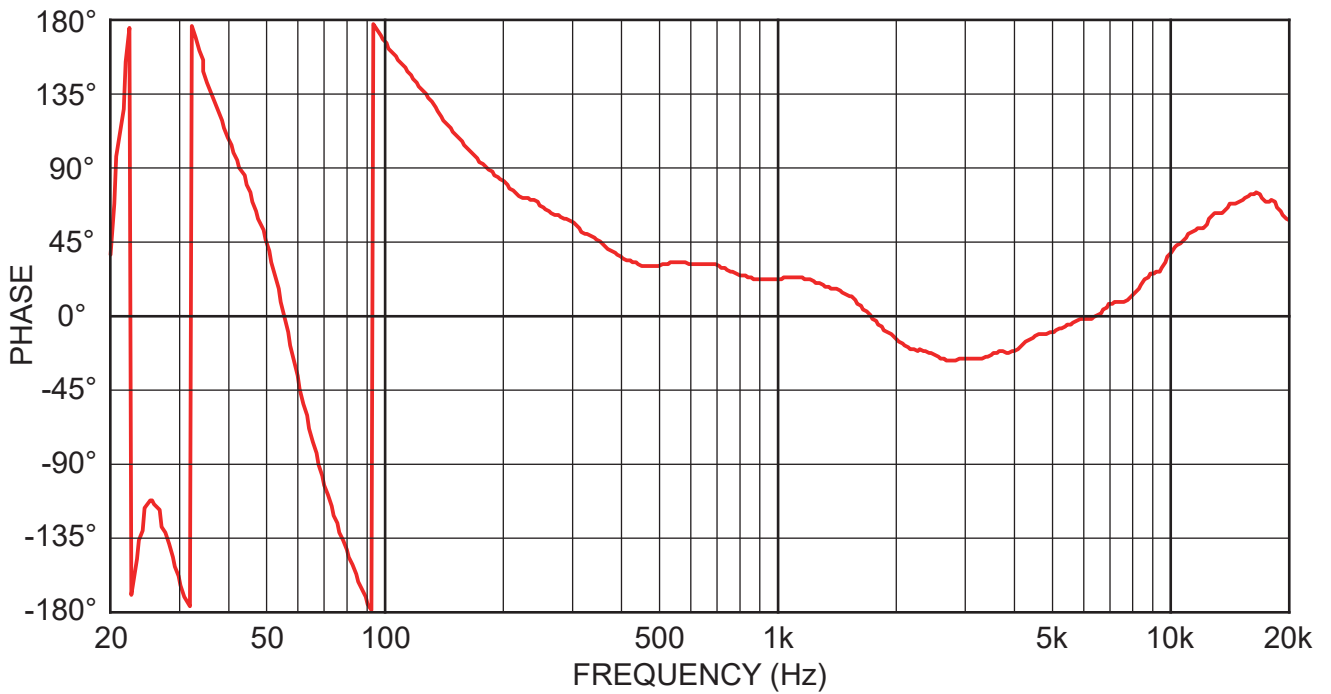

## Polar Plots

Horizontal

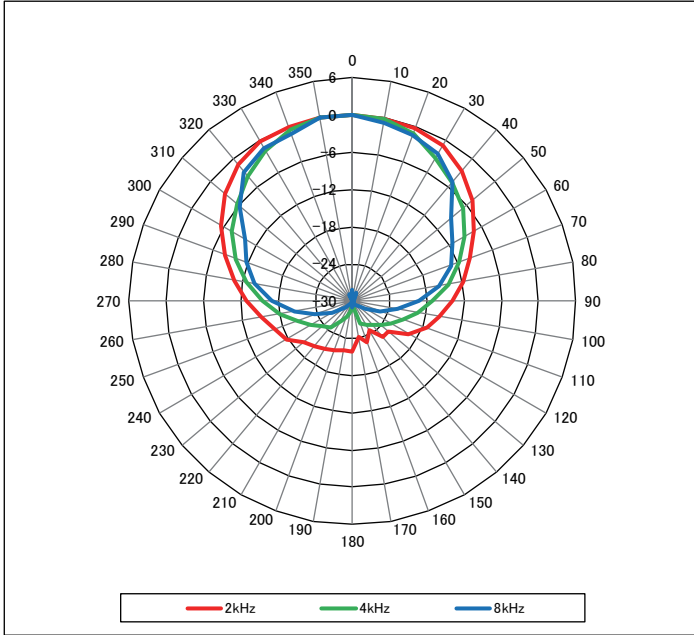

Vertical

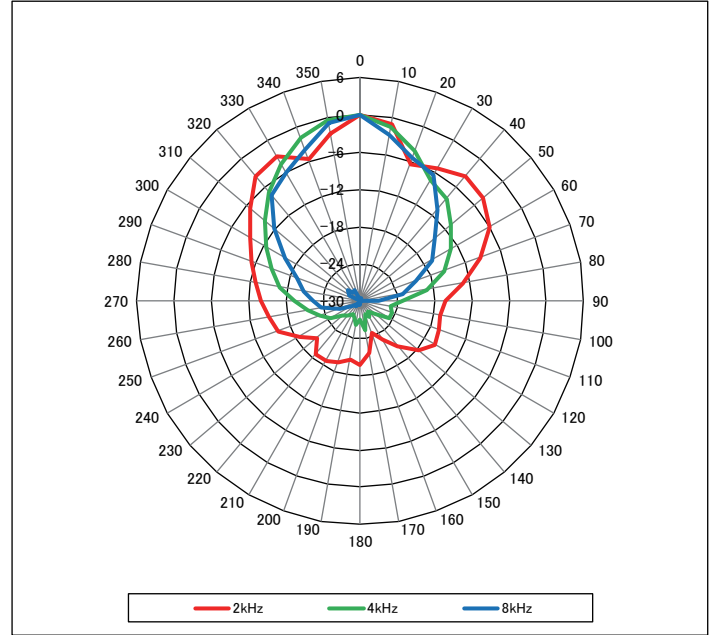

\*All information subject to change without notice.

\*All trademarks and registered trademarks are property of their respective owners.

Created in June, 2024

YAMAHA CORPORATION  
P.O.BOX 1, Hamamatsu Japan