

REVISION HISTORY OF: 020-001808-01			
REV	DESCRIPTION OF CHANGE	BY	REV. DATE
01	INITIAL RELEASE	PK	03/03/2013

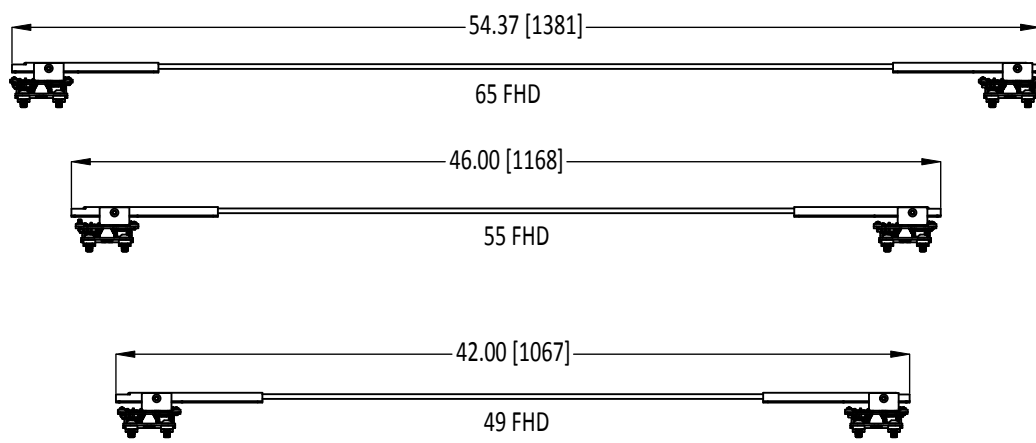

TOP VIEW

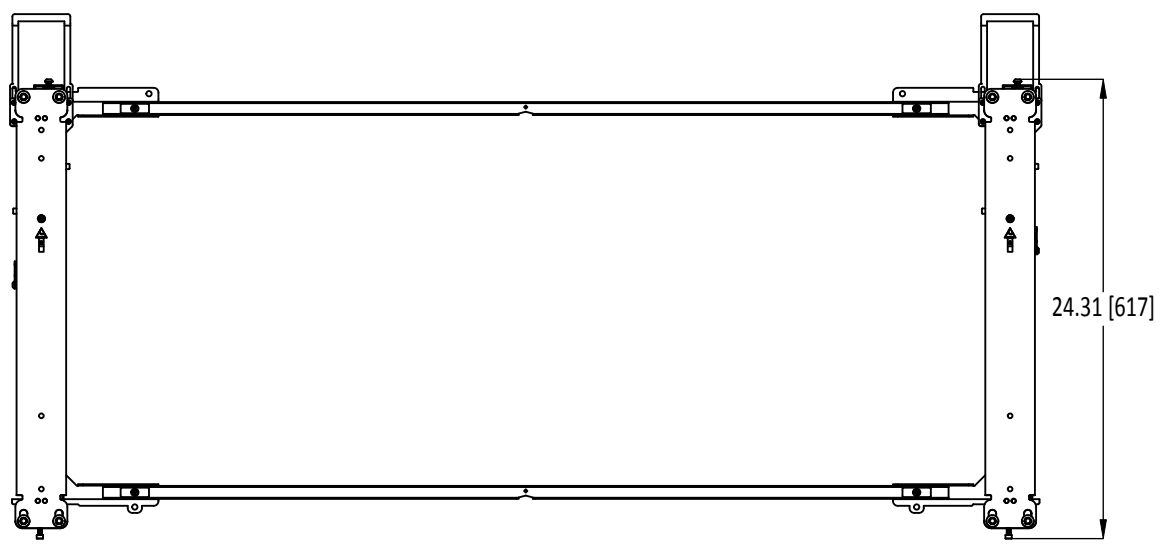

FRONT VIEW

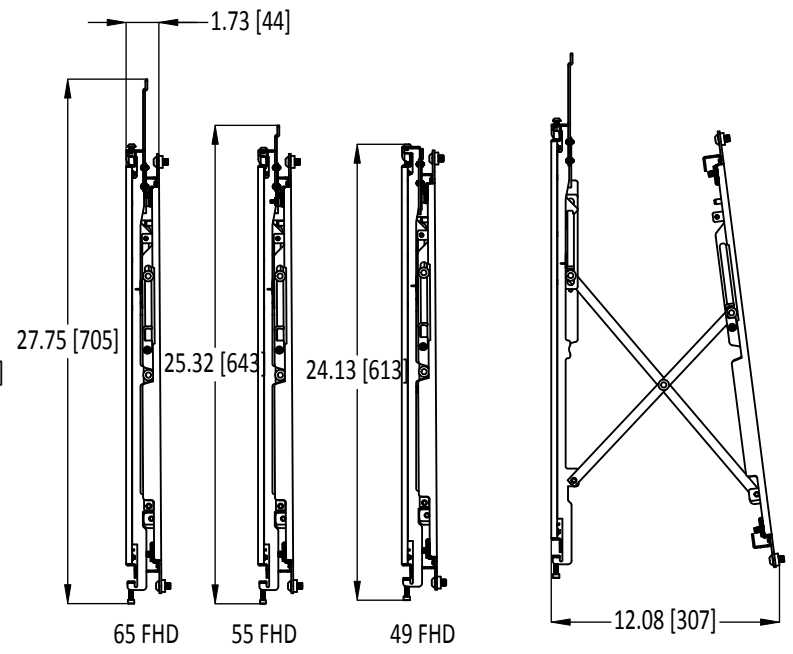

UNITS: INCHES	MILLIMETERS	PROPRIETARY	DATE: 03/03/2013
UNLESS OTHERWISE SPECIFIED, DIMENSIONS ARE TO BE TAKEN FROM THE CENTER OF GRAVITY UNLESS OTHERWISE SPECIFIED.		DESIGNED BY: [blank]	DATE: [blank]
TOLERANCES APPLY AS SHOWN BELOW		DRAWN BY: [blank]	DATE: [blank]
DECIMAL FRACTIONS	FRACTIONS	CHECKED BY: [blank]	DATE: [blank]
0.125	1/8	APPROVED BY: [blank]	DATE: [blank]
0.250	1/4	DATE: [blank]	
0.375	3/8		
0.500	1/2		
0.750	3/4		
1.000	1		
1.500	1 1/2		
2.000	2		
3.000	3		
4.000	4		
5.000	5		
6.000	6		
8.000	8		
10.000	10		
12.000	12		
15.000	15		
20.000	20		
25.000	25		
30.000	30		
40.000	40		
50.000	50		
60.000	60		
75.000	75		
100.000	100		
125.000	125		
150.000	150		
200.000	200		
250.000	250		
300.000	300		
400.000	400		
500.000	500		
600.000	600		
800.000	800		
1000.000	1000		
NOT TO BE REPRODUCED OR REPRODUCED IN ANY MANNER WITHOUT THE EXPRESS WRITTEN PERMISSION OF CHRISTIE		<p><b>CHRISTIE</b></p> <p>DWG Line ADA Mount ML25</p> <p>020-001808-01</p>	
<p>THIRD ANGLE PROJECTION</p>		<p>DATE: 03/03/2013</p> <p>SCALE: 1:3</p> <p>FILE: 020-001808-01</p> <p>SHEET 1 OF 1</p>	