

visual engineering
LIGHTWARE

User's Manual



VINX-120-HDMI-ENC
VINX-110-HDMI-DEC

VINX-210AP-HDMI-ENC
VINX-120AP-HDMI-ENC
VINX-110AP-HDMI-DEC
VINX-120AP-HDMI-ENC-DNT

WP-VINX-110P-HDMI-ENC

AV Over IP Multimedia Extender

Important Safety Instructions

Class II apparatus construction.

The equipment should be operated only from the power source indicated on the product.

To disconnect the equipment safely from power, remove the power cord from the rear of the equipment or from the power source. The MAINS plug is used as the disconnect device, the disconnect device shall remain readily operable.

There are no user-serviceable parts inside of the unit. Removal of the cover will expose dangerous voltages. To avoid personal injury, do not remove the cover. Do not operate the unit without the cover installed.

The appliance must be safely connected to multimedia systems. Follow instructions described in this manual.

Ventilation

For the correct ventilation and to avoid overheating, ensure enough free space around the appliance. Do not cover the appliance, leave the ventilation holes free and never block or bypass the ventilators (if there are any).

WARNING

To prevent injury, the apparatus is recommended to be securely attached to the floor/wall or mounted in accordance with the installation instructions. The apparatus shall not be exposed to dripping or splashing, and no objects filled with liquids, such as vases, shall be placed on the apparatus. No naked flame sources, such as lit candles, should be placed on the apparatus.

Waste Electrical & Electronic Equipment WEEE

This marking shown on the product or its literature indicates that it should not be disposed of along with other household wastes at the end of its working life. To prevent possible harm to the environment or human health from uncontrolled waste disposal, please separate this from other types of wastes and recycle it responsibly to promote the sustainable reuse of material resources. Household users should contact either the retailer where they purchased this product, or their local government office for details of where and how they can take this item for environmentally safe recycling. Business users should contact their supplier and check the terms and conditions of the purchase contract. This product should not be mixed with other commercial wastes for disposal.

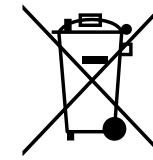

Caution: Laser Product



Common Safety Symbols

Symbol	Description
	Direct current
	Alternating current
	Double insulation
	Caution: for indoor use only
	Caution: possibility of electric shock
	Caution

Symbol Legend

The following symbols and markings are used in the document:

WARNING! Safety-related information that is highly recommended to read and keep in every case!

ATTENTION! Useful information for performing a successful procedure; it is recommended to read.

DIFFERENCE: Feature or function that is available with a specific firmware/hardware version or product variant.

INFO: A notice, which may contain additional information. Procedure can be successful without reading it.

DEFINITION: The short description of a feature or a function.

TIPS AND TRICKS: Ideas that you may have not known yet, but can be useful.

Navigation Buttons

 Go back to the previous page. If you clicked on a link previously, you can go back to the source page by pressing the button.

 Navigate to the Table of Contents.

 Step back one page.

 Step forward to the next page.

Document Information

All presented functions refer to the indicated products. The descriptions have been made while testing these functions in accordance with the indicated Hardware/Firmware/Software environment:

Item	Version
Firmware package version	3.4.0b3
Lightware Device Controller	2.6.4b1
Lightware Device Updater V2	2.17.0b2

Document revision: **v2.8**

Release date: **19-12-2022**

Editor: Tamas Forgacs

About Printing

Lightware Visual Engineering supports green technologies and eco-friendly mentality. Thus, this document is primarily made for digital use. If you need to print out a few pages for any reason, follow the recommended printing settings:

- Page size: A4
- Output size: Fit to page or Match page size
- Orientation: Landscape

TIPS AND TRICKS: Thanks to the size of the original page, a border around the content (gray on the second picture below) makes it possible to organize the pages better. After punching holes in the printed pages, they can easily be placed into a ring folder.

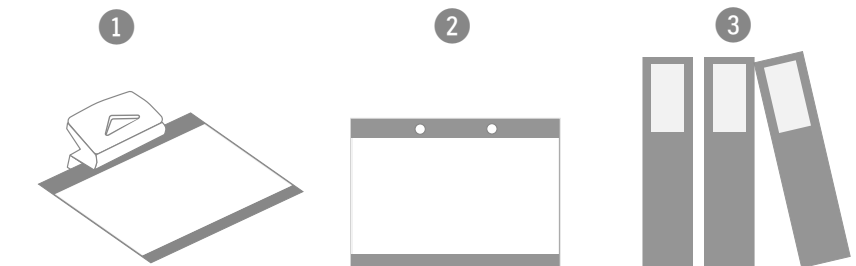

Hashtag (#) Keywords in the Document

This user's manual contains keywords with hashtags (#) to help you find the relevant information as quick as possible.

The format of the keywords is the following:

#<keyword>

The usage of the keywords: use the **Search** function (Ctrl+F / Cmd+F) of your PDF reader application, type the # (hashtag) character and the wished keyword.

The **#new** special keyword indicates a new feature/function that has just appeared in the latest firmware or software version.

Example

#dhcp

This keyword is placed at the DHCP (dynamic IP address) setting in the front panel operation, the Lightware Device Controller (LDC) and the LW3 programmer's reference section. See the list of all hashtag keywords of the document in the [Hashtag Keyword List](#).

Table of Contents

1. INTRODUCTION	7	4.2.3. Layout Examples	34	6.3.1. The LW3 Tree and Command Structures	58
1.1. DESCRIPTION	8	4.3. ANALOG AUDIO INTERFACE	35	6.3.2. Legend for the Control Commands	58
1.2. BOX CONTENTS	9	4.4. USB INTERFACE	36	6.3.3. General Rules	59
1.3. MODEL COMPARISON	10	4.5. DANTE® AUDIO OUTPUT INTERFACE	36	6.3.4. Command Types.....	59
1.4. FEATURES OF THE DEVICE	11	4.6. RS-232 INTERFACE	38	6.3.5. Prefix Summary	60
1.5. FURTHER FEATURES OF THE AP-SERIES	11	4.7. CLEARTEXT LOGIN FEATURE	38	6.3.6. Error Messages.....	60
1.6. TYPICAL APPLICATIONS	12	5. SOFTWARE CONTROL OPTIONS	39	6.3.7. Escaping.....	60
2. PRODUCT OVERVIEW	13	5.1. SOFTWARE CONTROL MODES	40	6.3.8. Signature	60
2.1. VINX-120-HDMI-ENC	14	5.2. CONNECTING USING LIGHTWARE DEVICE CONTROLLER	41	6.3.9. Subscription	61
2.2. VINX-110-HDMI-DEC	14	5.2.1. Updating the LDC.....	41	6.3.10. Notifications about the Changes of the Properties	61
2.3. VINX-120AP-HDMI-ENC	15	5.2.2. Running the LDC.....	41	6.4. SYSTEM COMMANDS	62
2.4. VINX-120AP-HDMI-ENC-DNT	16	5.3. CONNECTING VIA THE BUILT-IN WEB PAGE	42	6.4.1. Querying the Product Name	62
2.5. VINX-210AP-HDMI-ENC	17	5.4. MAIN SETTINGS (ENCODER)	43	6.4.2. Setting the Device Label.....	62
2.6. VINX-110AP-HDMI-DEC.....	18	5.4.1. General Settings	43	6.4.3. Querying the Serial Number	62
2.7. WP-VINX-110P-HDMI-ENC	19	5.4.2. Cleartext Login (Login Settings).....	44	6.4.4. Querying the Package Version.....	62
2.8. FRONT PANEL LEDs	20	5.4.3. Video Status and Settings.....	44	6.4.5. Resetting the Device.....	62
2.9. RJ45 LEDs	20	5.4.4. Audio Settings	45	6.4.6. Restoring the Factory Default Settings	62
2.10. FRONT PANEL BUTTONS	21	5.5. MAIN SETTINGS (DECODER)	45	6.5. CLEARTEXT LOGIN PROTECTION	63
2.10.2. Wallplate	21	5.5.1. General Settings	45	6.5.1. Setting the Login Password	63
2.11. DIP SWITCH	21	5.5.2. Video Status and Settings.....	46	6.5.2. Logging into the Device.....	63
3. INSTALLATION	22	5.5.3. Audio Settings	48	6.5.3. Logging out of the Device	63
3.1. MOUNTING OPTIONS	23	5.6. CROSSPOINT MENU	49	6.5.4. Enabling/Disabling the Cleartext Login Function.....	63
3.1.1. VESA100 Mounting Adapter for Extenders.....	23	5.6.1. Grid view.....	49	6.6. NETWORK CONFIGURATION	64
3.1.2. Rack Shelf Mounting	23	5.6.2. Tile view	50	6.6.1. Querying the IP Address.....	64
3.1.3. UD-kit Mounting	24	5.7. EDID MENU	51	6.6.2. Querying the IP Setup Mode (FW 2.x.x)	64
3.2. MOUNTING INTO THE POWERED RACKMOUNT CAGE	24	5.7.1. The EDID Memory Structure	51	6.6.3. Setting the IP Setup Mode (FW 2.x.x)	64
3.2.1. Features	24	5.7.2. EDID Operations.....	51	6.6.4. Querying the DHCP State (FW 1.x.x)	64
3.2.2. Assembling Steps.....	24	5.8. ADVANCED SETTINGS	52	6.6.5. Setting the DHCP State (FW 1.x.x)	65
3.3. MOUNTING THE WALL PLATE MODEL	26	5.8.1. Common Settings (Encoder and Decoder)	52	6.6.6. Setting a Static IP Address	65
3.4. ELECTRICAL CONNECTIONS	27	5.8.2. Decoder-related Settings	53	6.6.7. Querying the Subnet Mask.....	65
3.5. CONNECTING STEPS	29	5.8.3. LW3 Terminal	54	6.6.8. Setting a Static Subnet Mask	65
3.5.1. Preparing the Network	29	5.9. VIDEO WALL SETUP	55	6.6.9. Querying the Gateway Address	65
3.5.2. Point-to-Multipoint Transmission (Multicast Mode)	29	5.9.1. Creating a Video Wall	55	6.6.10. Setting a Static Gateway Address	66
3.5.3. Point-to-Point Transmission (Unicast Mode)	30	5.9.2. Identify the Decoders	55	6.7. ENCODER-RELATED COMMANDS	66
3.5.4. Installation Checkpoints	30	5.9.3. Gap and Bezel Settings	56	6.7.1. Querying the Input Video Signal Presence.....	66
4. DEVICE CONCEPT	31	5.9.4. Modifying a Video Wall	56	6.7.2. Querying the Resolution of the Input Video Signal.....	66
4.1. VINX DEVICE CONCEPT	32	5.9.5. Deleting a Video Wall	56	6.7.3. Querying the Active Input Port.....	66
4.2. VIDEO INTERFACE	32	6. PROGRAMMER'S REFERENCE	57	6.7.4. Querying the Video Input Selection Mode	66
4.2.1. One-to-one Video Transmission (Unicast Mode)	33	6.1. OVERVIEW	58	6.7.5. Setting the Video Input Selection Mode.....	67
4.2.2. One-to-All Video Transmission (Multicast Mode)	33	6.2. INSTRUCTIONS FOR THE TERMINAL APPLICATION USAGE	58	6.7.6. Querying the Video Quality Mode	67
		6.3. PROTOCOL RULES	58	6.7.7. Setting the Video Quality Mode	67
				6.7.8. Querying the HDCP State.....	67

Table of Contents

6.7.9. Setting the HDCP State	68	6.12.2. Setting the Baud Rate of the Port.....	75	7.7. THE UPDATING STEPS	90
6.7.10. Force HDCP Version.....	68	6.12.3. Setting the RS-232 Port Mode	76	7.8. COMMAND LINE INTERFACE (CLI)	92
6.8. DECODER-RELATED COMMANDS	68	6.12.4. Setting the Data Bits	76	7.8.1. How to Run.....	92
6.8.1. Querying the Resolution of the Output Video Signal	68	6.12.5. Setting the Stop Bits.....	76	7.8.2. How to Use.....	93
6.8.2. Querying the Scaling Mode of the Output Video Signal	68	6.12.6. Setting the Parity	76	7.9. CLI COMMANDS	93
6.8.3. Setting the Scaling Mode of the Output Video Signal.....	68	6.13. ARRANGING THE EXTENDERS TO GROUPS	77	7.9.1. Help	93
6.8.4. Querying the Signal Type of the Output Video Signal	69	6.13.1. Querying the Working Mode (Unicast/Multicast).....	77	7.9.2. LDU2 Version	93
6.8.5. Setting the Resolution of the Output Video Signal.....	69	6.13.2. Setting the Working Mode (Unicast/Multicast).....	77	7.9.3. Check For New LDU2 Version.....	93
6.8.6. Rotating the screen	69	6.13.3. Querying the Video Stream ID Setting Method.....	77	7.9.4. Device Info	94
6.8.7. Setting the No-signal-screen.....	69	6.13.4. Querying the DIP Switch Value	77	7.9.5. Update	94
6.8.8. Setting the State of the Output	70	6.13.5. Querying the Video Stream ID	78	7.9.6. Exit Codes	95
6.8.9. Setting the Delay of Muting the Audio During Switching	70	6.13.6. DIP Switch Enable	78	7.10. IF THE UPDATE IS NOT SUCCESSFUL.....	95
6.8.10. Setting the Switch Order	70	6.13.7. Setting the Video Stream ID.....	78	8. TROUBLESHOOTING	96
6.8.11. Using of Free Routing.....	71	6.14. VIDEO WALL SETTINGS	78	8.1. USE CASES	97
6.9. CUSTOM LOGO MANAGEMENT.....	71	6.14.1. Setting the Name of the Video Wall	78	8.2. HOW TO SPEED UP THE TROUBLESHOOTING PROCESS	97
6.9.1. Querying the Storage Size.....	71	6.14.2. Assigning a Decoder to a Video Wall	79	9. TECHNOLOGIES	98
6.9.2. Querying the Free Storage Size.....	71	6.15. SETTING UP A VIDEO WALL (EXAMPLE)	79	9.1. EDID MANAGEMENT.....	99
6.9.3. Querying the Number of Uploaded Files.....	71	6.16. CROSSPOINT SWITCHING EXAMPLES	80	9.1.1. Understanding the EDID	99
6.9.4. Querying the List of Uploaded Files	72	6.16.1. Switching an Input to an Output	80	9.1.2. Advanced EDID Management.....	99
6.9.5. Deleting a Custom Image.....	72	6.16.2. Switching an Input to All Outputs.....	80	9.2. AV OVER IP	100
6.9.6. Selecting a Custom Logo - No Connection to the Encoder	72	6.16.3. Switching the Source of a Video Wall	80	9.3. HDCP MANAGEMENT	100
6.9.7. Selecting a Custom Logo - No Active Video Signal.....	72	6.16.4. Multiple Switching.....	81	9.3.1. Protected and Unprotected Content	100
6.9.8. Selecting a Custom Logo to Be Forced Over the Active Video.....	72	6.17. EDID MANAGEMENT (ENCODER).....	81	9.3.2. Disable Unnecessary Encryption	100
6.9.9. Setting the Status of the Information Text.....	72	6.17.1. Querying the Emulated EDID.....	81	9.3.3. HDCP v2.2.....	101
6.9.10. Setting the Signal Type of the Output Video Signal	73	6.17.2. Setting the Emulated EDID on the Input Port.....	81	9.4. RS-232 SIGNAL MANAGEMENT (VINX AP-SERIES).....	102
6.9.11. Querying the State of the USB Connection.....	73	6.17.3. Copying an EDID	82	9.4.1. General Information	102
6.9.12. Establishing the USB Connection.....	73	6.17.4. Querying the Preferred Resolution of an EDID.....	82	9.4.2. Types of Serial Cables.....	102
6.10. AUDIO-RELATED COMMANDS.....	73	6.17.5. Deleting an EDID from the User Memory	82	9.4.3. Serial Device Types	102
6.10.1. Querying the Audio Input Selection Mode	73	6.18. LW3 COMMANDS - QUICK SUMMARY	83	9.4.4. RS-232 Signal Transmission over VINX Devices	102
6.10.2. Setting the Audio Input Selection Mode	73	7. FIRMWARE UPDATE	86	10. APPENDIX	103
6.10.3. Querying the Audio Signal Presence.....	74	7.1. BUILT-IN WEB OR LDU2.....	87	10.1. SPECIFICATIONS	104
6.11. ANALOG AUDIO INPUT/OUTPUT SIGNAL LEVEL SETTINGS.....	74	7.2. IMPORTANT NOTICES – BEFORE STARTING THE UPDATE.....	87	10.1.1. VINX Basic Series.....	104
6.11.1. Querying the Volume (Exact Value).....	74	7.3. ABOUT THE FIRMWARE PACKAGE (LFP/LFP2 FILE)	87	10.1.2. VINX AP-series	105
6.11.2. Setting the Volume (Exact Value).....	74	7.4. OPTION 1. – UPDATING VIA THE BUILT-IN WEB PAGE	87	10.1.3. VINX Wall plate.....	107
6.11.3. Setting the Volume (by a Step Value)	74	7.4.1. Firmware Updating Steps.....	87	10.2. DELAY IN THE VIDEO TRANSMISSION.....	109
6.11.4. Querying the Volume (in Percentage).....	74	7.5. OPTION 2. – UPDATING BY LDU2	88	10.3. FACTORY DEFAULT SETTINGS.....	109
6.11.5. Setting the Volume (in Percentage)	74	7.5.1. Introduction.....	88	10.4. DIP SWITCH STATES	109
6.11.6. Setting the Volume (by a Step Value in Percentage)	75	7.5.2. Preparation	88	10.5. MECHANICAL DRAWINGS	110
6.11.7. Querying the Mute State	75	7.5.3. About the Firmware Package (LFP2 File)	88	10.6. RS-232 CABLE WIRING GUIDE.....	112
6.11.8. Setting the Mute State	75	7.5.4. LDU2 Installation	88	10.7. SUPPORTED RESOLUTIONS.....	113
6.12. SERIAL PORT SETTINGS.....	75	7.6. RUNNING THE SOFTWARE	89		
6.12.1. Setting the Port Availability.....	75				

Table of Contents

10.8. FACTORY EDID LIST	115
10.9. FIRMWARE RELEASE NOTES	117
10.10. APPLICATION NOTE (LW-AN-001)	121
10.11. HASHTAG KEYWORD LIST	124
10.12. APPLIED PORTS (NETWORK SETTINGS)	125
10.13. AUDIO PORT NUMBERING.....	125
10.14. FURTHER INFORMATION.....	126

1

Introduction

Thank you for choosing Lightware's VINX Video Network Extender devices. In the first chapter we would like to introduce the device by highlighting the most important features in the sections listed below:

- ▶ [DESCRIPTION](#)
- ▶ [BOX CONTENTS](#)
- ▶ [MODEL COMPARISON](#)
- ▶ [FEATURES OF THE DEVICE](#)
- ▶ [FURTHER FEATURES OF THE AP-SERIES](#)
- ▶ [TYPICAL APPLICATIONS](#)

1.1. Description

VINX-120-HDMI-ENC and VINX-110-HDMI-DEC are LAN-based Encoder/Decoder multimedia extenders to extend HDMI video from a local source to a remote sink. The Encoder and Decoder devices connect either via a direct CATx cable connection or through a Gigabit Ethernet Switch in between. The maximum delivery distance can reach up to 100 m with minimal latency and employing a quality, proprietary wavelet transform based image compression.

The maximum supported resolution is 3840 x 2160 @ 30Hz with 7.1 audio. The devices support both static and dynamic (DHCP) IP address settings. Pre-programmed factory EDID presets and user EDIDs are stored in the Encoder. DIP switches serve quick manual setting for device pairing over the network, a quick and easy installation method. Gap and bezel compensation can be adjusted for video walls. Scaling is available on the receiver side and videos can be freely cropped.

VINX AP-series

The VINX 'AP-series' is the second generation of the VINX family. These products extend the features of the first generation with the following functions: VGA input port, Analog audio (de)embedding and transmission over SFP modules. Furthermore, the devices can be powered over Ethernet (PoE).

VINX-120AP-HDMI-ENC-DNT

This variant contains a special module that allows de-embedding the audio of the incoming HDMI signal and transmitting as a 2-channel Dante® or AES67 source via the extra RJ45 connector. See more details in the [Dante® Audio Output Interface](#) section.



Dante® is a registered trademark of Audinate Pty Ltd.

Compatible Devices

The VINX AP-series devices are compatible with the VINX-120-HDMI-ENC and VINX-110-HDMI-DEC (basic VINX) devices. Please note that certain features are not available when mixing VINX-AP and basic VINX devices:

	Basic series	AP series
Video input port	HDMI	HDMI, VGA *
Analog audio (de)embedding	✗	✓
Return audio (mono) – in unicast mode	✗	✓
Dante® or AES67 audio de-embedding	✗	✓ **
Network interface	RJ45	RJ45, SFP
Powering modes	local	local, PoE

* VGA is available in VINX-210AP-HDMI-ENC model only.

** In VINX-120AP-HDMI-ENC-DNT model only.

See more details in the [Model Comparison](#) section.

Model Denomination

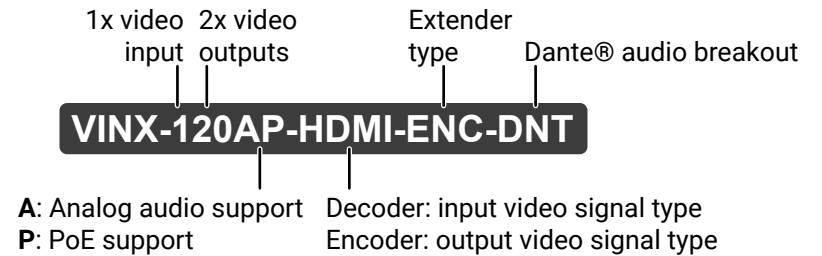

About the Serial Number



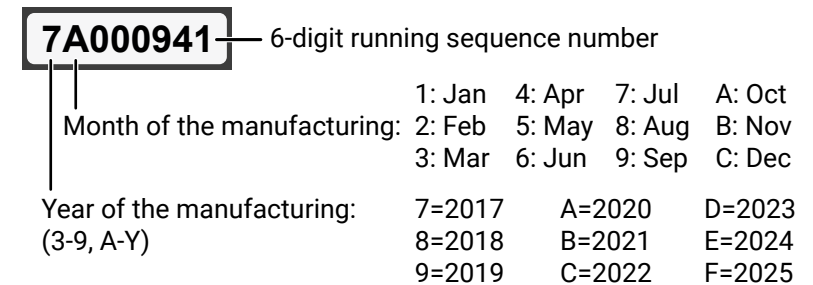



Lightware devices contain a label indicating the unique serial number of the product. The structure is the following:



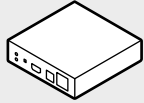

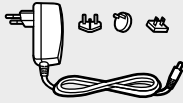

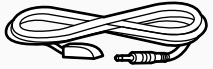
1.2. Box Contents

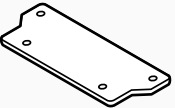
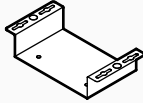
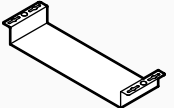
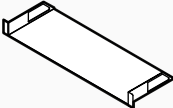
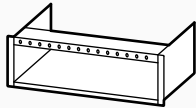
The assembling of certain accessories can be found in the [Mounting Options](#) section

Desktop models

	Supplied accessories					Optional accessories						
												
	Encoder / Decoder device	Safety and warranty info, QSG	5V DC adaptor	12 DC adaptor	Mounting screws (m3x4)	Infrared transmitter unit	Infrared receiver unit	VESA-100 compatible mounting adaptor	UD-kit	UD-kit double	1U high rack shelf	Powered rackmount cage (PRC-16-205)
VINX-110-HDMI-DEC	✓	✓	✓	-	✓ (2 pcs.)	-	✓	✓	✓	✓	✓	✓
VINX-120-HDMI-ENC	✓	✓	✓	-	✓ (2 pcs.)	✓	-	✓	✓	✓	✓	✓
VINX-110AP-HDMI-DEC	✓	✓	-	✓	✓ (2 pcs.)	-	✓	-	-	✓	✓	-
VINX-210AP-HDMI-ENC	✓	✓	-	✓	✓ (2 pcs.)	✓	-	-	-	✓	✓	-
VINX-120AP-HDMI-ENC	✓	✓	-	✓	✓ (2 pcs.)	✓	-	-	-	✓	✓	-
VINX-120AP-HDMI-ENC-DNT	✓	✓	-	✓	✓ (2 pcs.)	✓	-	-	-	✓	✓	-

Wallplate Model

	Supplied accessories				Optional accessories		
							
	Encoder device	Safety and warranty info, QSG	Fixing screws	Mounting screws	Phoenix Combicon 2-pole Connector	12V DC adaptor	Switch/outlet box (B225R)
WP-VINX-110P-HDMI-ENC	✓	✓	✓(4 pcs.)	✓(4 pcs.)	✓	✓	✓

1.3. Model Comparison

	Enclosure width		Power supply input			Inputs						Outputs					Control ports							
	1/4 RU	1/2 RU	5V DC	12V DC	PoE	HDMI	VGA	AV input		Analog audio	Microphone	HDMI	AV output		Dante® audio	Analog audio	RS-232		IR IN	IR OUT	USB type-A	USB mini-B	USB type-B	Ethernet
																	D-Sub9	RJ12						
VINX-120-HDMI-ENC	✓	-	✓	-	-	✓	-	-	-	-	-	✓	✓	-	-	-	-	✓	-	✓	-	✓	-	-
VINX-110-HDMI-DEC	✓	-	✓	-	-	-	-	✓	-	-	-	✓	-	-	-	-	-	✓	✓	-	✓	-	-	-
VINX-120AP-HDMI-ENC	-	✓	-	✓	✓	✓	-	-	-	✓	-	✓	✓	✓	-	✓	✓ (female)	-	-	✓	-	-	✓	-
VINX-120AP-HDMI-ENC-DNT	-	✓	-	✓	✓	✓	-	-	-	✓	-	✓	✓	✓	✓	✓	✓ (female)	-	-	✓	-	-	✓	-
VINX-210AP-HDMI-ENC	-	✓	-	✓	✓	✓	✓	-	-	✓	-	-	✓	✓	-	✓	✓ (female)	-	-	✓	-	-	✓	-
VINX-110AP-HDMI-DEC	-	✓	-	✓	✓	-	-	✓	✓	-	✓	✓	-	-	-	✓	✓ (male)	-	✓	-	✓	-	-	-
WP-VINX-110P-HDMI-ENC	-	-	-	✓	✓	✓	-	-	-	-	-	-	-	-	-	-	-	-	-	-	-	-	✓	✓

1.4. Features of the Device

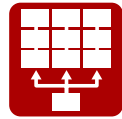

Video Wall Application

The VINX devices can be arranged to a Video wall of up to 8x8 Display devices. The displayed video can be the same on each display, one image enlarged to all the sinks, or the mixture of these.



Supporting 4K Resolution

Up to HDMI 2.0 4K 2160p@60Hz 4:2:0 video input or 3840 x 2160 @ 30Hz resolution over a 1 Gigabit network with very low latency.



3D Signal Support

The extenders support the transmission of 3D content in 'Side-by-side' and 'Top-to-bottom' modes.



Advanced EDID Management

The user can emulate any EDID on the inputs independently, read out and store any attached monitor's EDID in the User memory locations, upload and download EDID files.

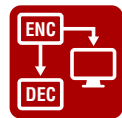

Local HDMI Output

A display device can be connected to the Encoder for local signal checking. The port carries the same video as the transmitted signal.



Frame Detector and Signal Analysis

The exact video and audio signal formats can be determined, such as timing, frequencies, scan mode, HDCP encryption, color range, color space and audio sample rate.



Image Adjustment

The extended video can be rotated or flipped at the Decoder side. Scaling is available at the Decoder side and videos can be freely cropped.



Built-in Website

Easy access from a web browser to control and configure the devices – even with a mobile device.

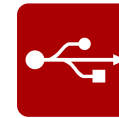

USB Extension

KVM extension for USB HID (Human Interface Devices, e.g. keyboard, mouse, presenter) and Mass Storage devices (Flash drive, Hard drive).



Serial Data Transmission

Transparent serial data transmission is available between the endpoints: Encoder and Decoder devices.

1.5. Further Features of the AP-series

DIFFERENCE: The features mentioned below refer to the VINX-110AP-HDMI-DEC, VINX-120AP-HDMI-ENC and VINX-210AP-HDMI-ENC models only.

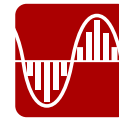

Analog Video Support

The extra VGA input port allows connecting analog video, which is converted to digital signal.



Analog Audio Support

External analog audio signal can be embedded in the video stream at the Encoder side, and can be de-embedded at the Decoder side.



SFP Module Support

The devices can be connected to the network switch over SFP modules.



Remote Power (PoE)

The devices can be Powered over Ethernet (according to IEEE 802.3af) by a compatible power source equipment.



Return Audio for a Microphone

Mono input port for a microphone from the Decoder towards the Encoder when the extender-pair is used in Unicast mode. Includes a 20 dB gain in the signal path.



Dante® or AES67 Audio De-embedding (VINX-120AP-HDMI-ENC-DNT only)

The audio of the HDMI signal can be transmitted as a 2-channel Dante® or AES67 source over the dedicated RJ45 connector.

1.6. Typical Applications

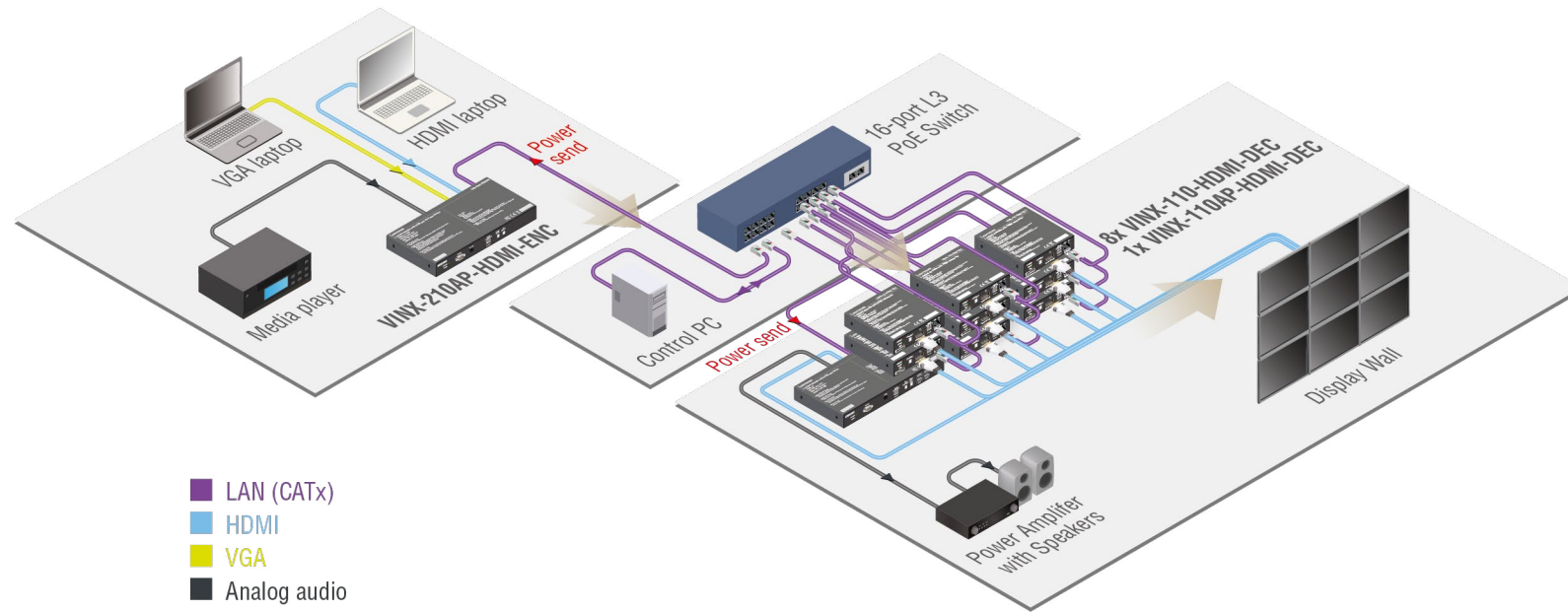

Video Wall Application (Multicast Mode)

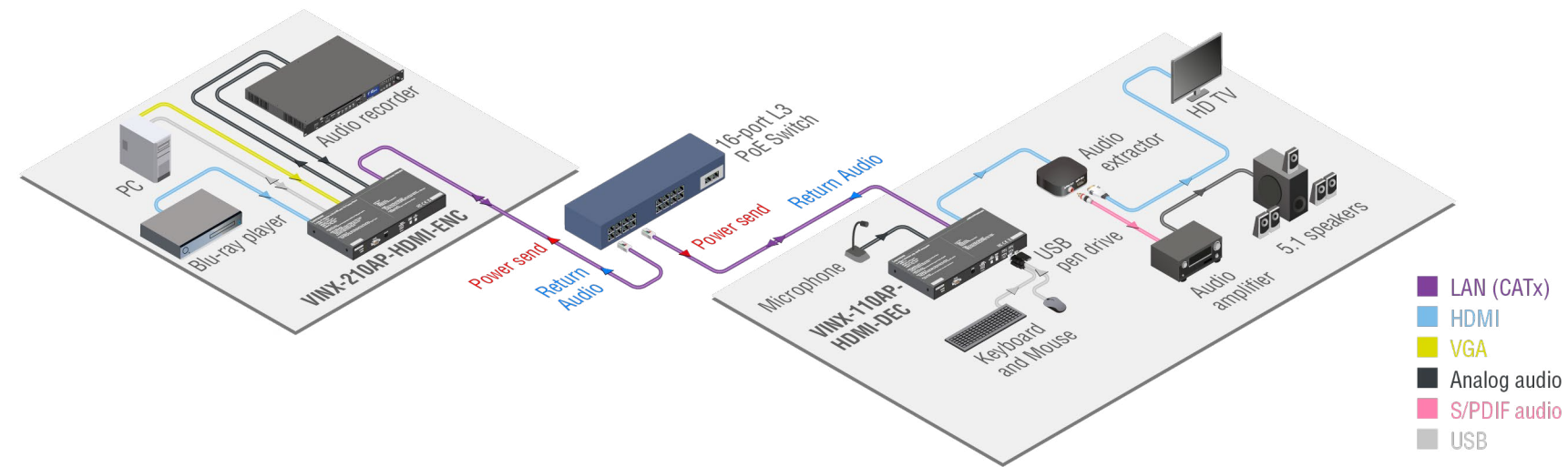

Simple Signal Extension (Unicast Mode)

2

Product Overview

The following sections are about the physical structure of the device, input/output ports, connectors, status LEDs and front panel button functions.

- ▶ [VINX-120-HDMI-ENC](#)
- ▶ [VINX-110-HDMI-DEC](#)
- ▶ [VINX-120AP-HDMI-ENC](#)
- ▶ [VINX-120AP-HDMI-ENC-DNT](#)
- ▶ [VINX-210AP-HDMI-ENC](#)
- ▶ [VINX-110AP-HDMI-DEC](#)
- ▶ [WP-VINX-110P-HDMI-ENC](#)
- ▶ [FRONT PANEL LEDs](#)
- ▶ [RJ45 LEDs](#)
- ▶ [FRONT PANEL BUTTONS](#)
- ▶ [DIP SWITCH](#)

2.1. VINX-120-HDMI-ENC

Front and Rear View

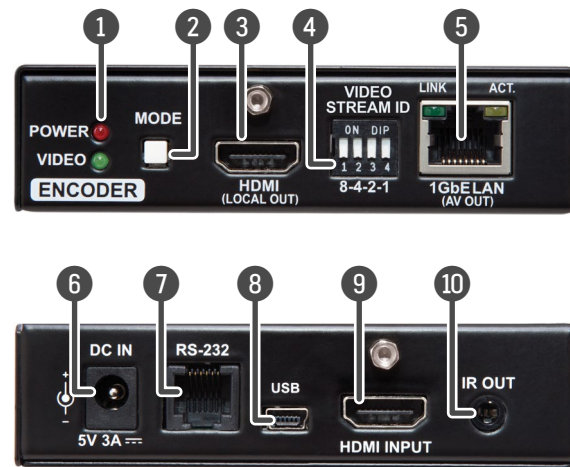

- 1 **Status LEDs** See the [Front Panel LEDs](#) section.
- 2 **Mode Button** **Short press:** switching between Video and Graphics modes.
Long press (more, than 10 seconds): reset to factory default settings.*
- 3 **HDMI Output Port** Forwarding the same Audio / Video content as the AV Output Port.
- 4 **DIP Switch** Linking Encoder and Decoder devices; for more information see the [DIP Switch](#) section.
- 5 **AV Output Port** RJ45 connector for outgoing AV signal to the Decoder device or Network switch. Applied cable shall be max. 100 m (CAT5 or CAT7).
- 6 **DC 5V Input** 5V DC input for local power supply.
- 7 **RS-232 Port** RJ12 connector for transparent serial communication (point-to-point or point-to-multi point).
- 8 **USB Port** Mini B-type connector for USB pass-through (IP KVM) application.
- 9 **HDMI Input Port** Video port for DVI or HDMI signal.
- 10 **IR Output Port** IR signal output connector (for 3.5 mm Jack, 3-pole, TRS plug).

* From firmware version v3.3.1, factory defaults may only be called this way for 90 seconds after booting up.

WARNING! Always use the supplied 5V power adaptor. Warranty void if damage occurs due to use of a different power source.

2.2. VINX-110-HDMI-DEC

Front and Rear View

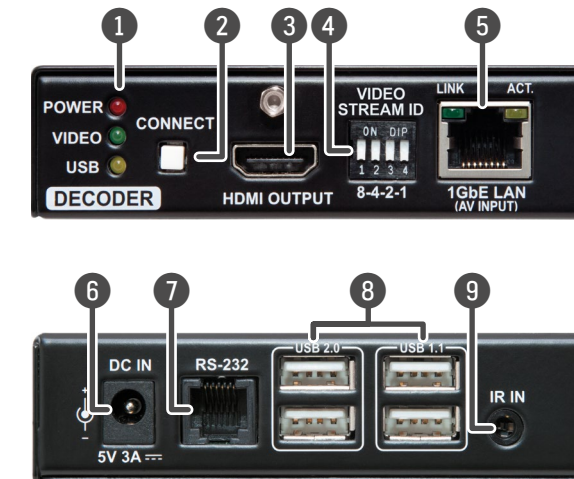

- 1 **Status LEDs** See the [Front Panel LEDs](#) section.
- 2 **Connect Button** **Short press:** acquire USB connection (this is required only in Multicast mode)
Long press (more than 10 seconds): reset to factory default settings.*
- 3 **HDMI Output Port** HDMI output to a sink device.
- 4 **DIP Switch** Linking Encoder and Decoder devices; for more information, see the [DIP Switch](#) section.
- 5 **AV Input Port** RJ45 connector for incoming AV signal from the Encoder device or Network switch. Applied cable shall be max. 100 m (CAT5 or CAT7).
- 6 **DC 5V Input** 5V DC input for local power supply.
- 7 **RS-232 Port** RJ12 connector for transparent serial communication (point-to-point or point-to-multi point).
- 8 **USB Ports** USB 1.1 and 2.0 compatible A-type ports for transmitting USB HID and mass storage devices. USB 1.1 port can be used for changing the video stream by a keyboard, see the [Keyboard Shortcuts](#) section.
- 9 **IR Input Port** IR signal input connector (for 3.5 mm Jack, 3-pole, TRS plug).

* From firmware version v3.3.1, factory defaults may only be called this way for 90 seconds after booting up.

2.3. VINX-120AP-HDMI-ENC

Front View

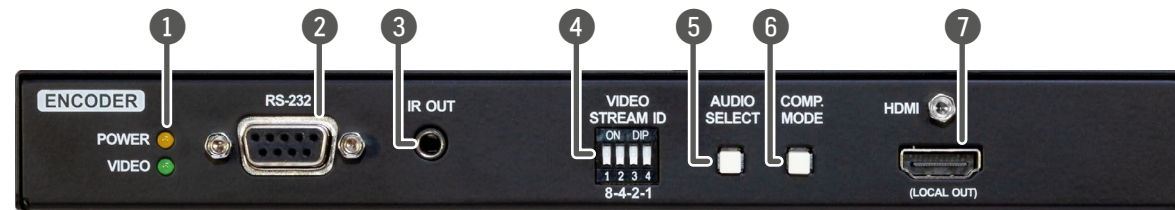

- | | | |
|---|--------------------------------|---|
| 1 | Status LEDs | See the Front Panel LEDs section. |
| 2 | RS-232 Port | D-SUB9 connector for transparent serial communication (point-to-point or point-to-multi point). |
| 3 | IR Output Port | IR signal output connector (for 3.5 mm Jack, 3-pole, TRS plug). |
| 4 | DIP Switch | Linking Encoder and Decoder devices (HW setting). |
| 5 | Audio Select button | Press the button to toggle between the following modes:
<div style="text-align: center;"> Auto → HDMI → Analog audio </div> |
| 6 | Compression Mode Button | Short press: switching between the Video and Graphics modes.
Long press (more than 10 seconds): reset to factory default settings.* |
| 7 | HDMI Output | For a local sink device (mirrored from the AV output). |

* From firmware version v3.3.1, factory defaults may only be called this way for 90 seconds after booting up.

Rear View

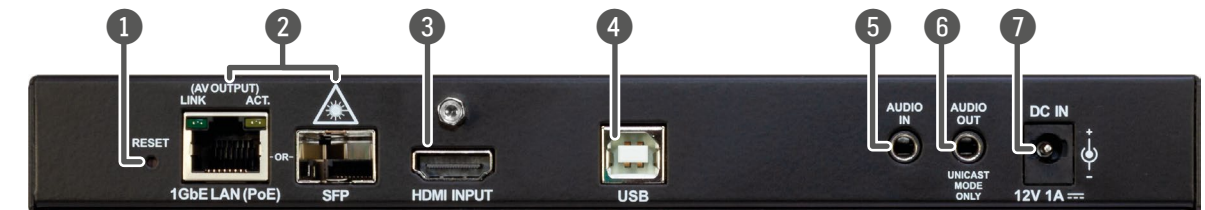

- | | | |
|---|--------------------------|---|
| 1 | Reset Button | Reboots the device. |
| 2 | AV Input Ports | RJ45 connector and slot for an SFP module. One at a time is available for receiving an AV signal. Applied cable shall be max. 100 m (CAT5 or CAT7) in case of RJ45. Please note that SFP module is not supplied with the device. |
| 3 | HDMI Input Port | Video port for DVI or HDMI signal. |
| 4 | USB Port | B-Type connector for USB pass-through application (e.g. for connecting the Encoder to a computer). |
| 5 | Audio Input Port | For unbalanced analog audio signal. |
| 6 | Audio Output Port | Presenting the audio signal coming from the Audio input port of the connected Encoder . This feature is available only in Unicast mode , and if the Analog audio input is selected as an audio source on the Encoder . |
| 7 | DC 12V Input | 12V DC input for local power supply. |

2.4. VINX-120AP-HDMI-ENC-DNT

Front View

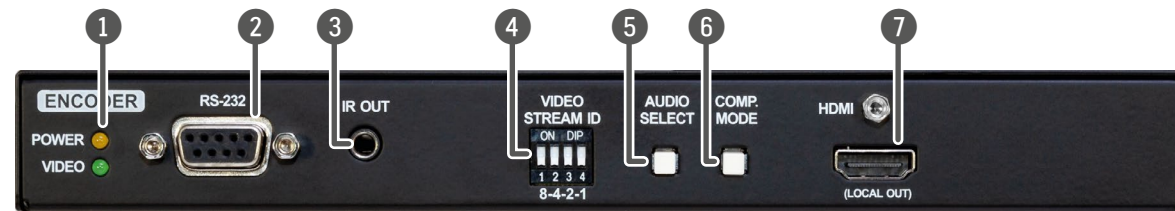

Rear View

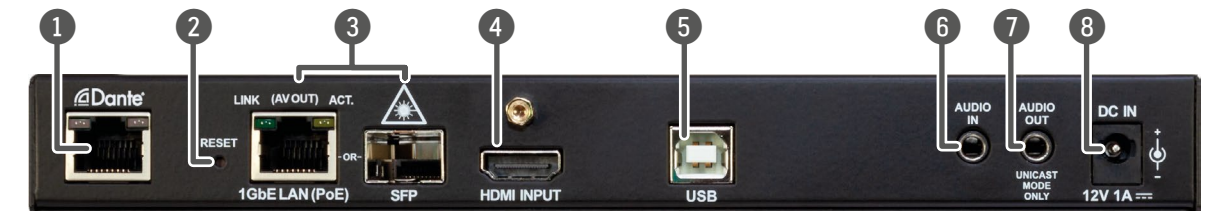

- | | | |
|---|--------------------------------|---|
| 1 | Status LEDs | See the Front Panel LEDs section. |
| 2 | RS-232 Port | D-SUB9 connector for transparent serial communication (point-to-point or point-to-multi point). |
| 3 | IR Output Port | IR signal output connector (for 3.5 mm Jack, 3-pole, TRS plug). |
| 4 | DIP Switch | Linking Encoder and Decoder devices (HW setting). |
| 5 | Audio Select button | Press the button to toggle between the following modes:
<div style="text-align: center;"> Auto → HDMI → Analog audio </div> |
| 6 | Compression Mode Button | Short press: switching between the Video and Graphics modes.
Long press (more than 10 seconds): reset to factory default settings.* |
| 7 | HDMI Output | For a local sink device (mirrored from the AV output). |

* From firmware version v3.3.1, factory defaults may only be called this way for 90 seconds after booting up.

- | | | |
|---|----------------------------|---|
| 1 | Dante® Audio Output | RJ45 connector for de-embedding the HDMI audio, which can be transmitted as a 2-channel Dante® or AES67 source. Applied cable shall be max. 100 m (CAT5 or CAT7). |
| 2 | Reset Button | Reboots the device. |
| 3 | AV Input Ports | RJ45 connector and slot for an SFP module. One at a time is available for receiving an AV signal. Applied cable shall be max. 100 m (CAT5 or CAT7) in case of RJ45. Please note that SFP module is not supplied with the device. |
| 4 | HDMI Input Port | Video port for DVI or HDMI signal. |
| 5 | USB Port | B-Type connector for USB pass-through application (e.g. for connecting the Encoder to a computer). |
| 6 | Audio Input Port | For unbalanced analog audio signal. |
| 7 | Audio Output Port | Presenting the audio signal coming from the Audio input port of the connected Encoder . This feature is available only in Unicast mode , and if the Analog audio input is selected as an audio source on the Encoder . |
| 8 | DC 12V Input | 12V DC input for local power supply. |

2.5. VINX-210AP-HDMI-ENC

Front View

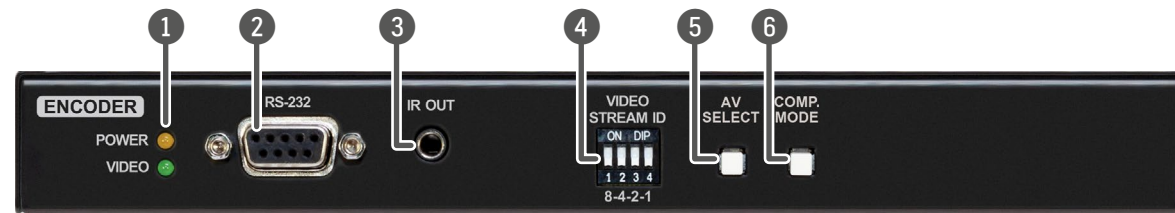

Rear View

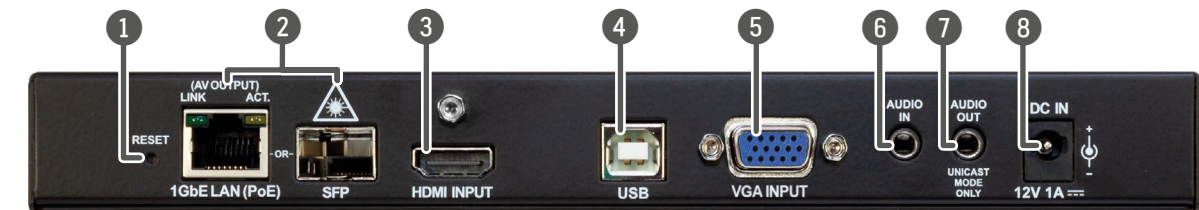

- | | | |
|----------|--------------------------------|--|
| 1 | Status LEDs | See the Front Panel LEDs section. |
| 2 | RS-232 Port | D-SUB9 connector for transparent serial communication (point-to-point or point-to-multi point). |
| 3 | IR Output Port | IR signal output connector (for 3.5 mm Jack, 3-pole, TRS plug). |
| 4 | DIP Switch | Linking Encoder and Decoder devices (HW setting). |
| 5 | AV Select Button | Press the button to toggle between the following modes:
<div style="text-align: center; margin: 5px 0;"> → Auto → HDMI+Embedded audio ← </div> <div style="text-align: center; margin: 5px 0;"> ← VGA+Analog audio ← HDMI+Analog audio → </div> |
| 6 | Compression Mode Button | See more details in the Front Panel Buttons section.
Short press: switching between the Video and Graphics modes.
Long press (more than 10 seconds): reset to factory default settings.* |

* From firmware version v3.3.1, factory defaults may only be called this way for 90 seconds after booting up.

- | | | |
|----------|--------------------------|--|
| 1 | Reset Button | Reboots the device. |
| 2 | AV Input Ports | RJ45 connector and slot for an SFP module. One at a time is available for receiving an AV signal. Applied cable shall be max. 100 m (CAT5 or CAT7) in case of RJ45. Please note that SFP module is not supplied with the device. |
| 3 | HDMI Input Port | Video port for DVI or HDMI signal. |
| 4 | USB Port | B-Type connector for USB pass-through application (e.g. for connecting the Encoder to a computer). |
| 5 | VGA Input Port | Video port for analog VGA signal on VINX-120AP-HDMI-ENC. |
| 6 | Audio Input Port | For unbalanced analog audio signal. |
| 7 | Audio Output Port | Presenting the audio signal coming from the Mic in input port of the connected Decoder . This feature is available only in Unicast mode , and if the Analog audio input is selected as an audio source on the Encoder . |
| 8 | DC 12V Input | 12V DC input for local power supply. |

2.6. VINX-110AP-HDMI-DEC

Front View

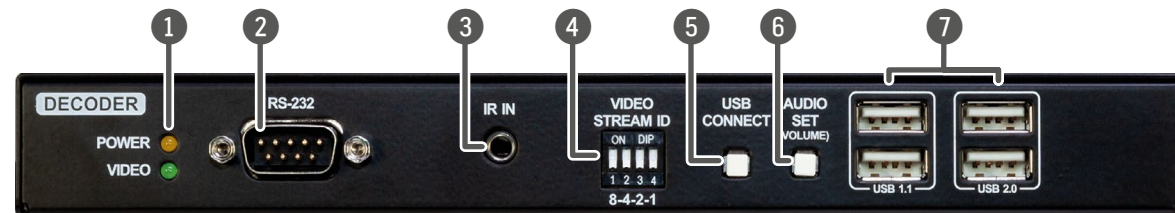

- | | | |
|---|---------------------------|--|
| 1 | Status LEDs | See the Front Panel LEDs section. |
| 2 | RS-232 Port | D-SUB9 connector for transparent serial communication (point-to-point or point-to-multi point). |
| 3 | IR Input Port | IR signal input connector (for 3.5 mm Jack, 3-pole, TRS plug). |
| 4 | DIP Switch | Linking Encoder and Decoder devices (HW setting). |
| 5 | USB Connect Button | Short press: acquire USB connection (this is required only in Multicast mode).
Long press (more than 10 seconds): reset to factory default settings. |
| 6 | Audio Set Button | Short press: the analog audio output volume is increased by 10%.
Long press (more than 5 seconds): the analog audio output volume is set to 0%. |
| 7 | USB Ports | USB 1.1 and 2.0 compatible A-type ports for transmitting USB HID and mass storage devices. USB 1.1 port can be used for changing the video stream by a keyboard, see the Keyboard Shortcuts section. |

* From firmware version v3.3.1, factory defaults may only be called this way for 90 seconds after booting up.

Rear View



- | | | |
|---|--------------------------|---|
| 1 | Reset Button | Reboots the device. |
| 2 | AV Input Ports | RJ45 connector and slot for an SFP module. One at a time is available for receiving an AV signal. Applied cable shall be max. 100 m (CAT5 or CAT7) in case of RJ45. Please note that SFP module is not supplied with the device. |
| 3 | HDMI Output | HDMI output to a sink device on VINX-120AP-HDMI-DEC. |
| 4 | MIC Input Port | Mono input port for a microphone including +20 dB gain in the signal path. |
| 5 | Audio Output Port | Presenting the audio signal coming from the Audio input port of the connected Encoder . |
| 6 | DC 12V Input | 12V DC input for local power supply. |

WARNING! The microphone input port applies a fixed bias to feed the connected electret (condenser) microphone. Thus, it is not suitable for dynamic microphones that do not contain isolation or an impedance matching transformer. (Danger of damage to the microphone.)

2.7. WP-VINX-110P-HDMI-ENC

Front view

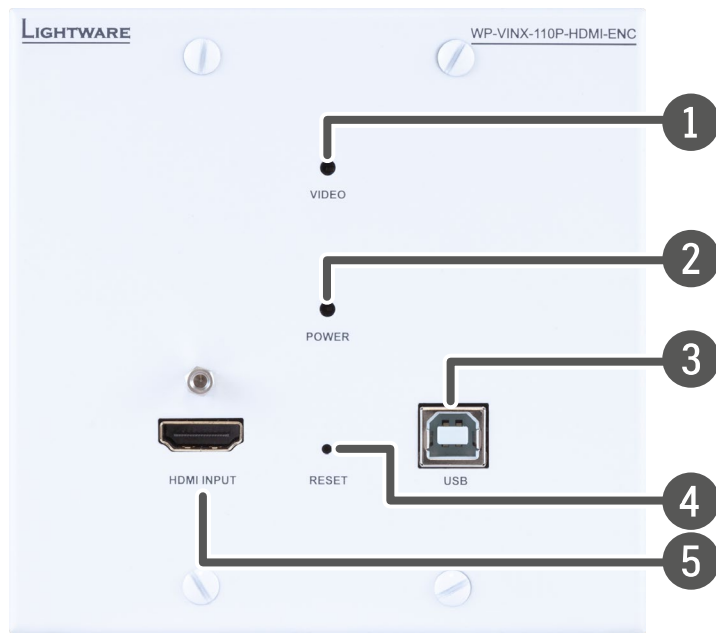

Side view

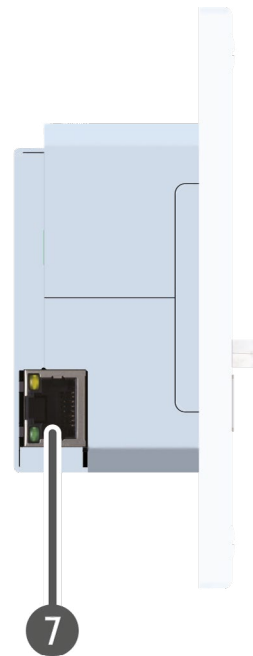

Rear view

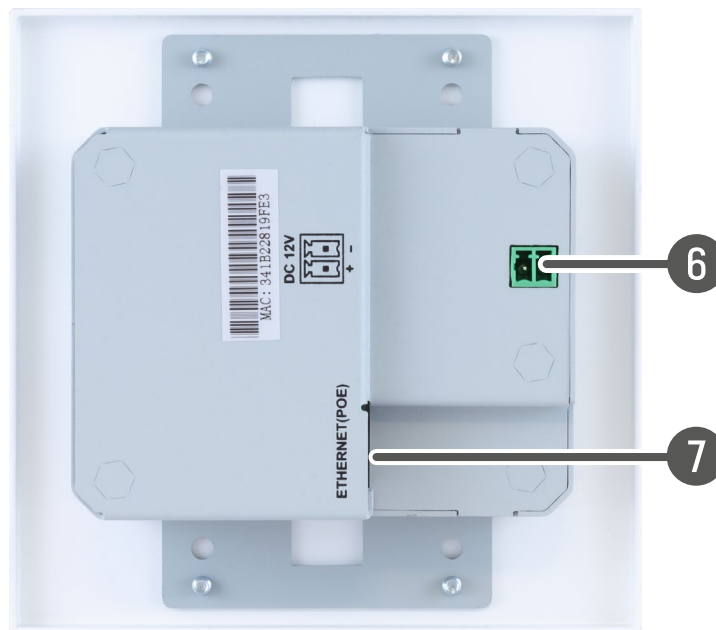

- 1 Video signal status LED**

The LED gives immediate feedback about the current video signal status of the device.

 - off There is no network connection.
 - ◉ blinking (green) The device is connected to a network, but there is no video stream in progress.
 - on The device is connected to a network and there is video streaming in progress.

- 2 Power status LED**

The LED gives immediate feedback about the current power status on the device.

 - off The device is not powered.
 - ◉ blinking (red) The device is booting.
 - on The device is powered on.

- 3 USB port**

B-Type connector for USB pass-through application (e.g. for connecting the Encoder to a computer).

- 4 Reset button**

Reboots the device.

- 5 HDMI input port**

Port for DVI or HDMI video signal.

- 6 DC input port**

12V DC input connector for local powering.

- 7 Ethernet port**

Locking RJ45 connector for Ethernet connection. Can also be used to power the device remotely over Ethernet (PoE).

2.8. Front Panel LEDs

INFO: Even if the colors of the LEDs in the devices are different, the functions are the same.

POWER LED

- **OFF:** the device is not powered.
- **BLINKING:** booting is in progress.
- **ON:** the device is powered on.

VIDEO LED

- **OFF:** there is no network connection.
- **BLINKING:** the device is connected to a network, but there is no video stream in progress.
- **ON:** the device is connected to a network and video stream is in progress.

USB LED (only in Decoders)

- **OFF:** there is no USB transmission between the Encoder and the Decoder.
- **ON:** the USB transmission is active between the Encoder and the Decoder.

POWER and VIDEO LEDs (only in Encoders)

- **BLINKING together:** there is a Video Stream ID clash in the network, e.g. another Encoder is set to the same Video Stream ID.

2.9. RJ45 LEDs

AV In/Out

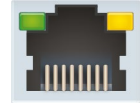
	Left LED, Green	Right LED, Yellow
	Link	Activity

Dante® Audio Out

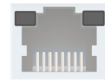
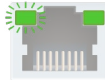
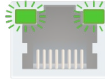
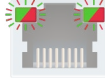
LED state	Left LED	Right LED	Function
	Off	Off	No power
	Solid green	Solid red	Dante is booting
	Blinking green	Solid green	Slave with sync (normal operation)
	Blinking green	Blinking green	Clock master (normal operation)
	Blinking green	Blinking red	Acquiring clock sync (normal operation)
	Alternating red/green	Alternating red/green	Identify (blinking for 6 seconds)
	Blinking red	Blinking red	Dante fail safe
	Blinking amber	Blinking amber	Device is upgrading

2.10. Front Panel Buttons

2.10.1.

Audio Select Button *#button*

Toggle between the following modes:

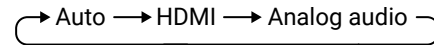

Auto: the Analog audio input port is selected when a plug is connected.

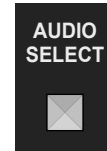

Mode and Compression Mode Buttons

- **Short press:** switching between the Movie and Graphics modes.
- **Long press** (more than 10 seconds): reset to factory default settings.

ATTENTION! From firmware version v3.3.1, factory defaults may only be called this way for 90 seconds after booting up.

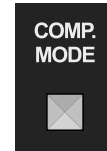

When the network bandwidth is not enough to transmit the video signal, the following modes are available in the Encoder:

- **Movie mode** (Lower image quality @ Less bandwidth): The image quality is adjusted to the available bandwidth. If the bandwidth is decreased, the image quality will be lower, but the video streaming will be continuous.
- **Graphics mode** (Best image quality @ High bandwidth): The image quality is kept at a high level. If the bandwidth is decreased, the image quality does not change, but frame drop may appear.

The setting takes effect when the available bandwidth is less than required.

AV Select Button

Toggle between the following modes:

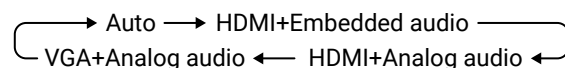

- **Auto mode:** the first connected source shall remain active as long as signal is present on the respective input. If sync is lost for at least 3 seconds, it will be switched over to the other source. No automatic switch back to the original input takes place when the signal is restored.



Connect and USB Connect Buttons

When the button is pressed for less than ten seconds, the USB connection is acquired. This is necessary only in Multicast mode; when Unicast mode is active, the assignment is arranged automatically.



Audio Set Button

- **Short press:** the analog audio output volume is increased by 10%.
- **Long press** (more than 5 seconds): the analog audio output volume is set to 0%.

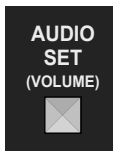

2.10.2. Wallplate

Reset Button

- **Short press:** reboots the device.
- **Long press** (more than 10 seconds): reset to factory default settings.

ATTENTION! From firmware version v3.4.0, factory defaults may only be called this way for 90 seconds after booting up.

2.11. DIP Switch

DIFFERENCE: The WP-VINX-110P-HDMI-ENC model does not have a DIP switch, its Video Stream ID can only be set in the LDC or in the Built-In Web.

The DIP switch can be used to set the Video Stream ID manually (HW setting). The interpretation of the DIP switch values can be found in the [DIP Switch States](#) section; please see the examples below:

DIP Switch State	Video Stream ID		/SYS/MB/GPIO.DipSwitch value
	Set by	Value	
	SW setting	see the built-in web	0x0
	HW setting	1	0x1
	HW setting	8	0x8

INFO: The HW setting of the DIP switch allows setting the Video Stream ID from 1 to 15. Higher Video Stream IDs (up to as much as 9999) can only be set using the Lightware Device Controller or the built-in-web.

#led #dipswitch #videostreamid #streamid

3

Installation

This chapter is about the installation of the device and connecting to other appliances, also presenting the mounting options and further assembly steps.

- ▶ [MOUNTING OPTIONS](#)
- ▶ [MOUNTING INTO THE POWERED RACKMOUNT CAGE](#)
- ▶ [MOUNTING THE WALL PLATE MODEL](#)
- ▶ [ELECTRICAL CONNECTIONS](#)
- ▶ [CONNECTING STEPS](#)

3.1. Mounting Options

WARNING! For fixing the device to a Rack shelf, use the screws supplied with the extender. Longer screws may touch internal parts and harm the device.

3.1.1. VESA100 Mounting Adapter for Extenders

DIFFERENCE: VESA100 Mounting Adapter can be used with the quarter-rack sized VINX extenders.

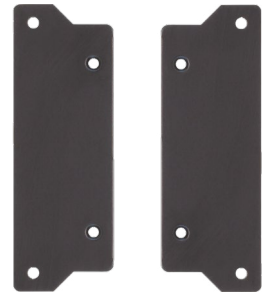

Mounting under the Desk

Two pieces of the adapter are needed for this kind of mounting. Fasten the adapters to the bottom of the extender and the desk as shown in the figure:

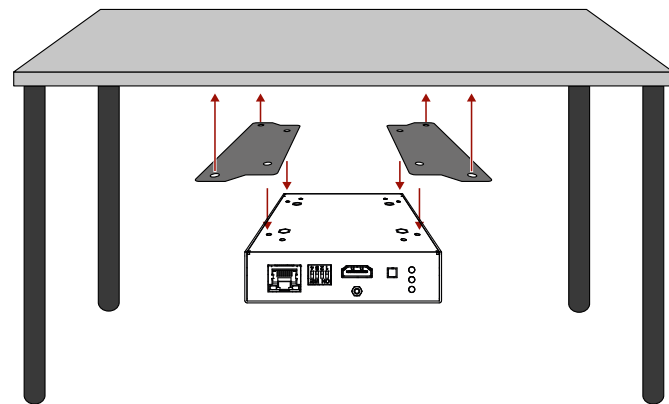

Mounting to a Display Device

Two mounting holes can be found on the bottom of the extender at each side; the VESA-compatible accessory plate can be fixed as indicated. The other two holes of the plate can be fixed to a VESA-compatible device (e.g. rear panel of an HDTV).

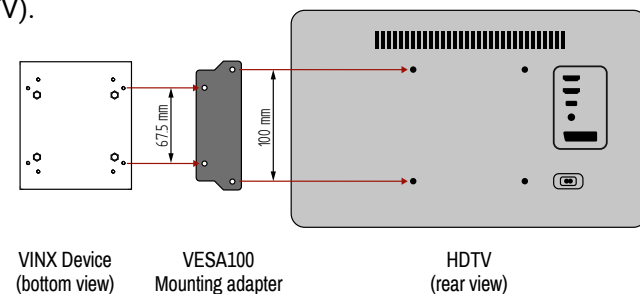

3.1.2. Rack Shelf Mounting

WARNING! For fixing the device to a Rack shelf, use the screws supplied with the extender. Longer screws may touch internal parts and harm the device.



The 1U high rack shelf provides mounting holes for the fastening of up to four VINX devices and putting them into a standard rack cabinet (width of the Rack shelf is 448 mm – without the ears). Fix the device to the Rack shelf as shown in the figure:

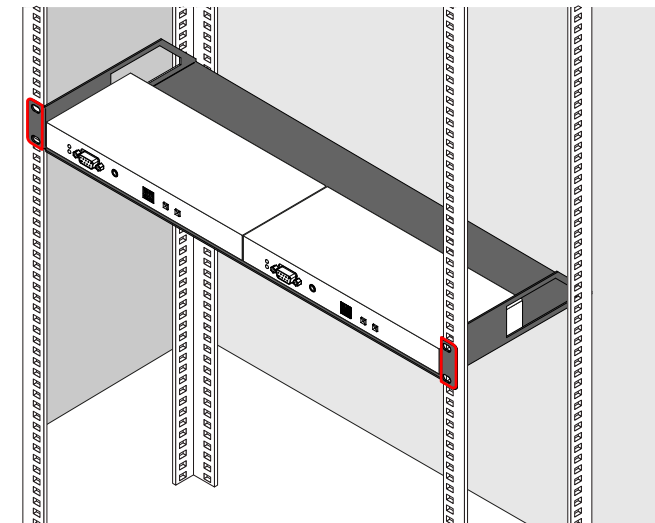

3.1.3. UD-kit Mounting

WARNING! For fixing the device to a Rack shelf, use the screws supplied with the extender. Longer screws may touch internal parts and harm the device.

Mounting with UD-kit double (Under Desk Double)



INFO: The fixing method is the same in case of UD-kit (for a quarter-rack sized device).

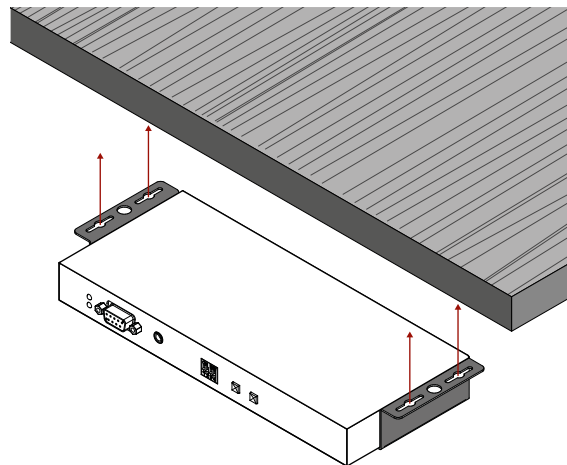

More details about the accessories and the mounting can be found in the [Mounting Assembly Guide](#).

3.2. Mounting into the Powered Rackmount Cage

DIFFERENCE: Only the VINX-110-HDMI-ENC and VINX-120-HDMI-DEC devices are compatible with the PRC-16-205 Rackmount Cage.



The PRC-16-205 rackmount cage can be used to install up to 16 VINX devices in the same cabinet.

3.2.1. Features

- 16 slots for VINX devices in any combination.
- Built-in power supply unit for the devices.
- Easy to install, as the cage is rack mountable: 3U-high, 1U-wide.
- The built-in blowers ensure the proper ventilation and airflow.
- The structure of the cage allows different arrangements, not only for VINX devices.

For further information, please see the Quick Start Guide of the [Rackmount Cage](#).

3.2.2. Assembling Steps

Step 1. Assembling the extender bracket.

Fasten the mounting bracket (highlighted with grey) onto the bottom of the extender with the provided M3x5mm PH flat head black screws (2 pcs./bracket) with a PH1 screwdriver.

Required screw:



M3x5, PH, flat head, black

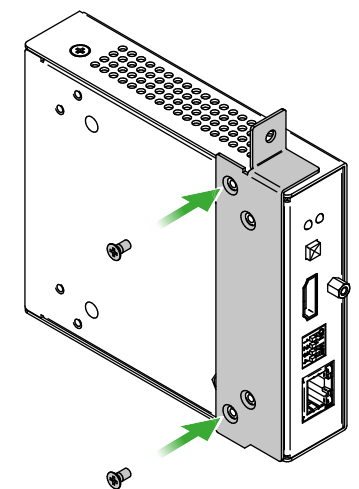

Step 2. 5V DC power cable connection.

Pull out the 5V DC power cable (highlighted with grey) belonging to the desired slot from the enclosure, and connect it to the power connector of the extender.

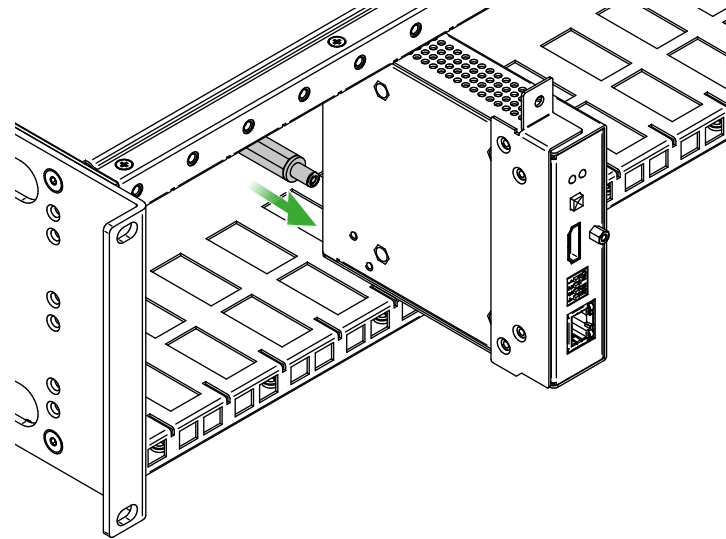
**Step 3.** Fastening the extender in the mounting slot.

Place the extender (highlighted with grey) to the desired mounting slot, and fasten the extender bracket with 1 pc M4x8mm PH, D head unpainted screw with a PH1 screwdriver. Pay attention to the guide rails of the cage when placing the extender.

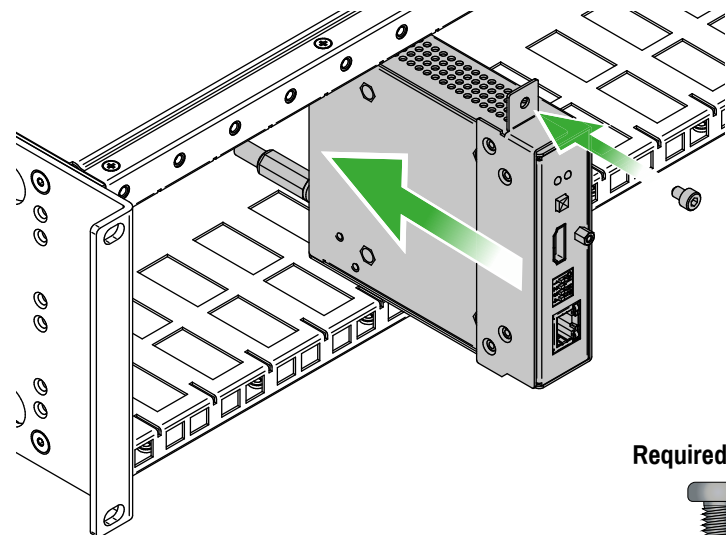

Required screw:

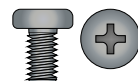

M4x8, PH, D head, unpainted

Step 4. Assembly of the Rack Ears and the Cable Guides.

The structure of the rack ears and the cable guides allow three kinds of installations in the Powered Rackmount Cage. The rack ears (highlighted with blue) are assembled to the front side in the foremost position. Two cable guides (highlighted with green) are assembled to the device, one is to the front side in the middle position, the second one is to the rear side in the lower position.

INFO: The example below is recommended if you have a deep rack, and you need cabling on the front and the rear side as well.

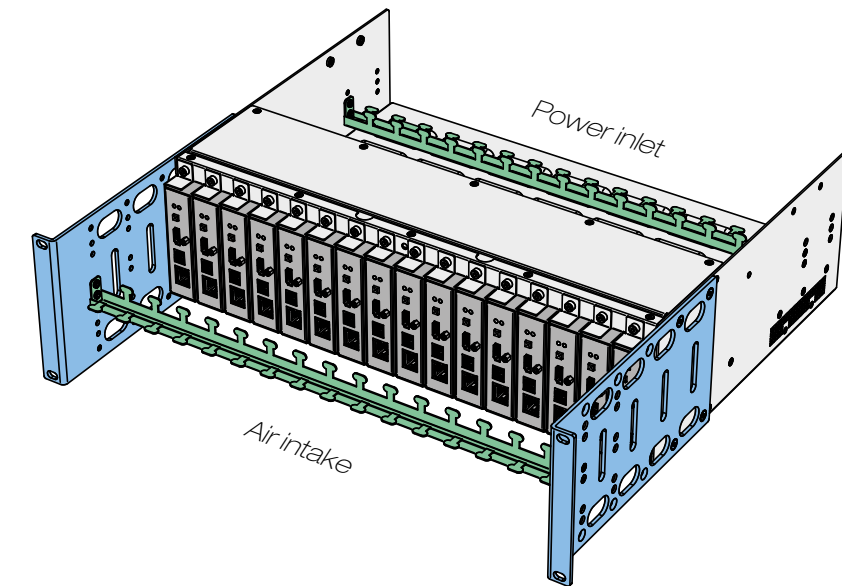
**Other Compatible Devices**

The rackmount cage is compatible with other Lightware extenders, too:

- HDMI-OPT-TX100
- HDMI-OPT-TX100R
- HDMI-OPT-TX200R
- HDMI-OPT-RX100
- HDMI-OPT-RX100R
- HDMI-OPT-RX200R
- HDMI-3D-OPT-RX150RA

3.3. Mounting the Wall Plate Model

Switch / Outlet Box Compatibility Table

Compatible Lightware Devices:

Model	Color of the front panel
WP-VINX-110P-HDMI-ENC White	White
WP-VINX-110P-HDMI-ENC Black	Black

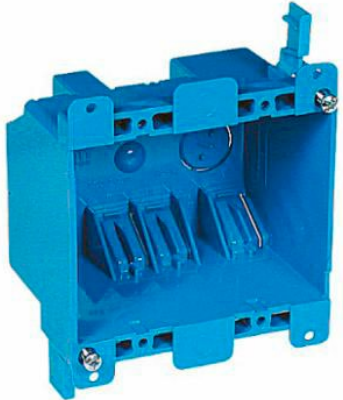
Type	Part number	Picture
Carlon B225R-UPC	7TAA040070R0000	

Mounting Steps

The encoder can be easily mounted into an industrial standard switch/outlet box (B225R):

INFO: The switch/outlet box is not supplied with the mounting kit but it can be purchased separately. Please contact sales@lightware.com for the details.

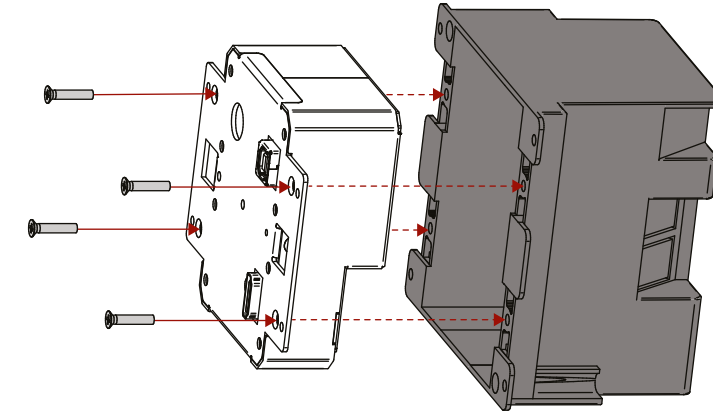

Step 1. Insert the extender into the B225R outlet box and position it to get the holes aligned.

Step 2. Fasten the front side of the extender to the B225R outlet box by fitting the four flat-headed screws.

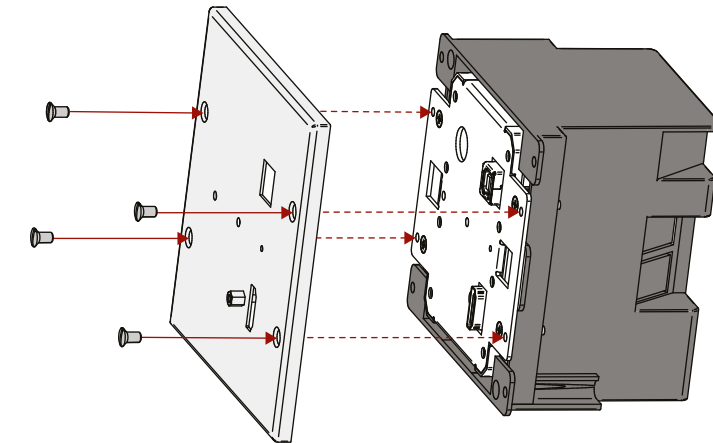

Step 3. Place the cover on the front side of the extender and position it to get the holes aligned.

Step 4. Fasten the cover to the front side of the extender by fitting the four round-headed screws.

3.4. Electrical Connections

1 GbE LAN and Dante® Audio Out

The devices provide standard RJ45 connectors for outgoing/incoming Video/Control signals. Always use high quality Ethernet cable for connecting Encoders and Decoders.

INFO: The connector type and the applied cable is the same for the Dante® audio output.

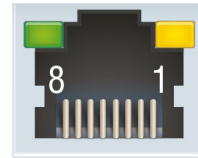

The Wiring of the Twisted Pair Cables

The recommended termination is based on TIA/EIA T 568 A or TIA/EIA T 568 B standards:

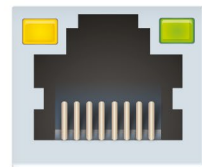

Pin	TIA/EIA T568A	TIA/EIA T568B
1	white/green	white/orange
2	green	orange
3	white/orange	white/green
4	blue	blue
5	white/blue	white/blue
6	orange	green
7	white/brown	white/brown
8	brown	brown

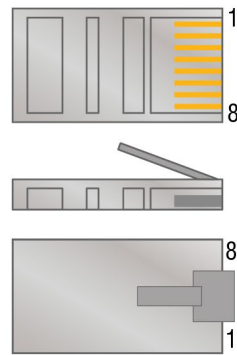

HDMI Input and Output Ports

The devices are assembled with standard 19-pole HDMI connectors for inputs and outputs. Special HDMI cables can be fastened to the housing by the nut.



USB Ports

The USB ports allow USB extension. The Encoders are assembled with USB B or mini-B type port (connecting a computer), and the Decoder devices contain two USB 1.1 and two USB 2.0 compatible A-type port. For more information about the USB extension see the [USB Interface](#) section.



Dante® is a registered trademark of Audinate Pty Ltd.

SFP Slots

The module inserted in the SFP slot can be used for network connection (AV transmission). Please note that SFP module is not supplied with the product.

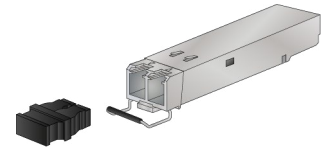

DEFINITION: The small form-factor pluggable (SFP) is a compact, hot swappable optical module transceiver used for both telecommunication and data communication applications. It is a popular industry format jointly developed and supported by many network component vendors. The SFP interface supports data rates up to 1 Gbit/s. *

ATTENTION! Please note that only one of the network ports is available at the same time in a device: either the SFP or the RJ45. When SFP is connected to a network, the RJ45 port is disabled.

* Source: https://en.wikipedia.org/wiki/Small_form-factor_pluggable_transceiver

Maximum Allowed Optical Cable Length

The maximum allowed optical cable length depends on the installed SFP modules. Always check the specification of the optical modules before the fiber optical cabling.

Analog Audio Ports

DIFFERENCE: The connectors mentioned below can be found only on the AP-series' devices.

Input and Output Ports

The connectors are used for receiving/sending unbalanced analog audio signal. They are also known as (3.5 mm or approx. 1/8") audio jack, phone jack, phone plug and mini-jack plug.

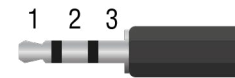

Pin nr.	Signal
1	Left
2	Right
3	Ground



Jack audio plug pin assignments

ATTENTION! The input is noise-sensitive. Applying an unearthed audio source or using a Dual Transformer/ Isolator (DTI) device is highly recommended.

ATTENTION! Do not connect a headphone to the Audio output port.

Microphone Input Port (Return Audio)

Mono input port for microphones, including +20 dB gain in the signal path (compared to the forward audio signal level). If this input is connected to a powered equipment, hum noise issue may occur. In this case an isolation transformer (a passive DI box) can help.

ATTENTION! The microphone input port applies a fixed bias to feed the connected electret (condenser) microphone. Thus, it is not suitable for dynamic microphones that do not contain isolation or an impedance matching transformer. (Danger of damage to the microphone.)



Microphone audio plug pin assignments

RS-232 Port

The Basic VINX-series

The quarter rack-sized devices contain a standard RJ12 connector, which is used for RS-232 serial connection. The port can be used to connect serial devices via the supplied serial cables.

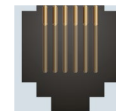

The AP-series

The half rack-sized devices contain a standard D-sub9 connector for RS-232 serial connection. The pinout of the connectors are different as follows:

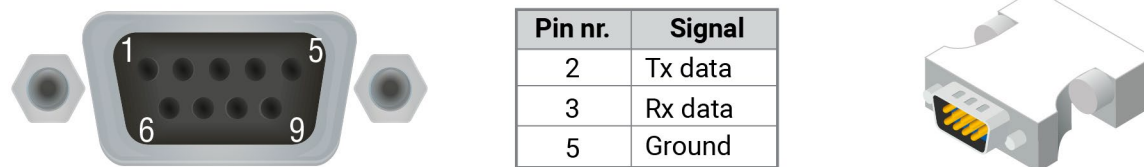

VINX-120AP-HDMI ENC and VINX-210AP-HDMI-ENC (DCE units)

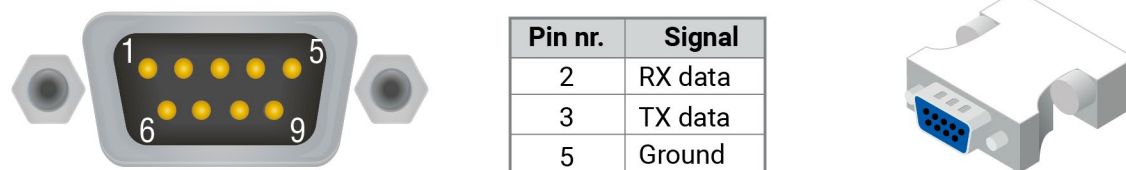

VINX-110AP-HDMI-DEC (DTE unit)

Please see the [RS-232 Interface](#) section for more details about the practical usage, and the [RS-232 Signal Management \(VINX AP-Series\)](#) section for details about the signal transmission.

3.5. Connecting Steps

ATTENTION! Please make sure that the VINX devices within a system run the same firmware (package version). If the firmwares are different, the seamless working is not guaranteed.

3.5.1. Preparing the Network

For the correct installation, build a Local Area Network with a Layer 3 (L3) type switch (highly recommended). However, Unicast mode requires only a Layer 2 (L2) switch. In both cases, the switch must support the Multicast routing.

ATTENTION! VINX Encoder and Decoder send certain system commands over multicast packages. If the multicast routing is disabled on the network, the signal transmission may fail.

Layer 2 vs. Layer 3 Switch

The VINX Encoders and Decoders use multicast routing. The managed switch in the network shall offer the following capabilities:

- IGMPv2
- IGMP snooping
- IGMP fast leave
- IGMP Querier
- Multicast filtering
- 9k MTU - Jumbo/Giant frames

These features are supported by the Layer 3 type switches. Please see more technical information about the network requirements in the [Application Note \(LW-AN-001\)](#) section.

3.5.2. Point-to-Multipoint Transmission (Multicast Mode)

- HDMI** Connect an HDMI source device (e.g. a computer) to the HDMI input port of the Encoder. Connect HDMI display devices to the HDMI output port of the Decoder devices for the Video Wall application.
- VGA** Connect the desired VGA source (e.g. a laptop) to the Encoder.
- RS-232** Optionally for RS-232 serial transmission: connect the desired devices (e.g. a touch Control, relay box) to the RS-232 ports by the supplied serial cables.
- USB** Optionally for USB extension: connect USB devices to the USB ports of the Decoders. Connect the desired host device (e.g. computer) to the Encoder via the USB mini-B type port.
- Audio** Optionally for audio transmission: connect the desired audio source device (e.g. a media player) to the audio input port of the Encoder. Optionally for audio extraction: connect an audio amplifier and speakers to the audio output port of the Decoder.
- CATx** Connect CATx cables between the VINX devices and the L3 Switch. Applied cable shall be max. 100 m (CAT5 or CAT7).
- Power** For devices with local power only: connect the power cord of the supplied adaptor to the DC input first, then to the AC power socket.

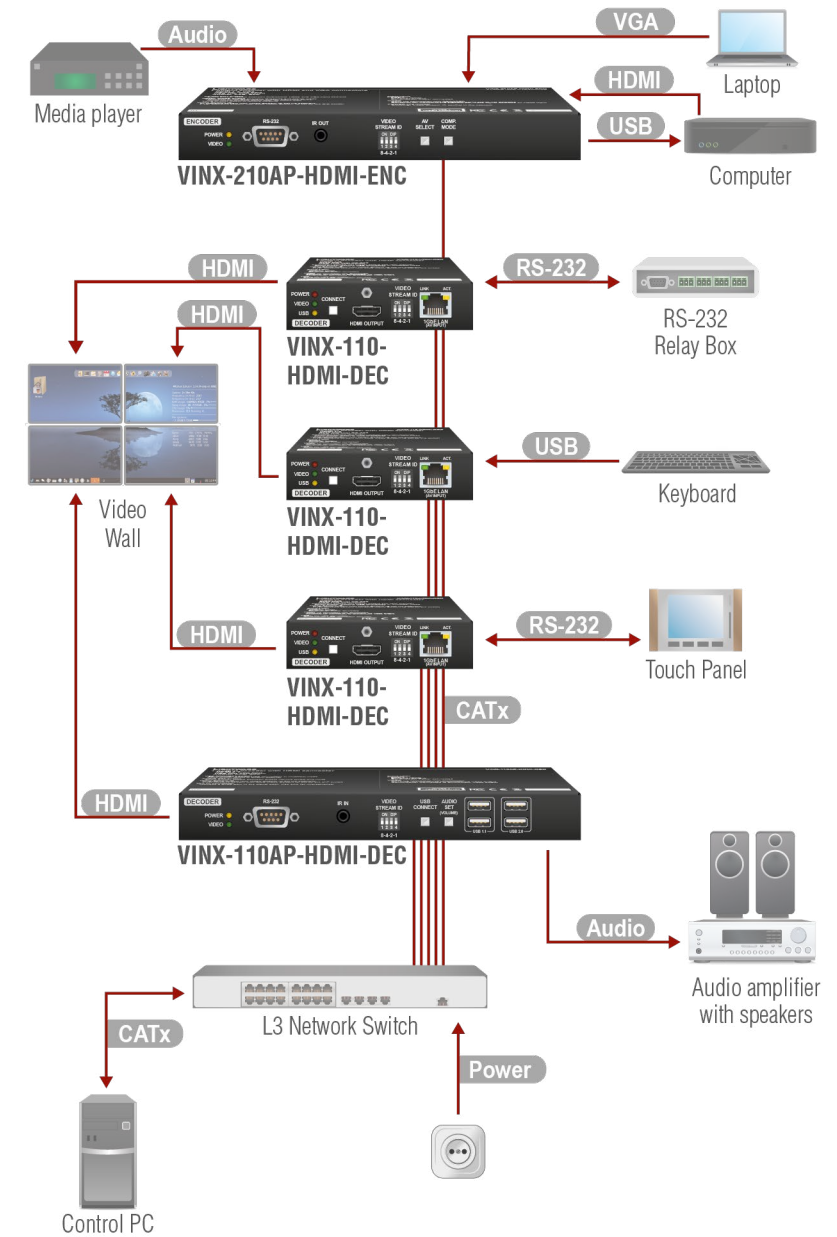

For more information about installation techniques, please see the [Installation Checkpoints](#) section.

3.5.3. Point-to-Point Transmission (Unicast Mode)

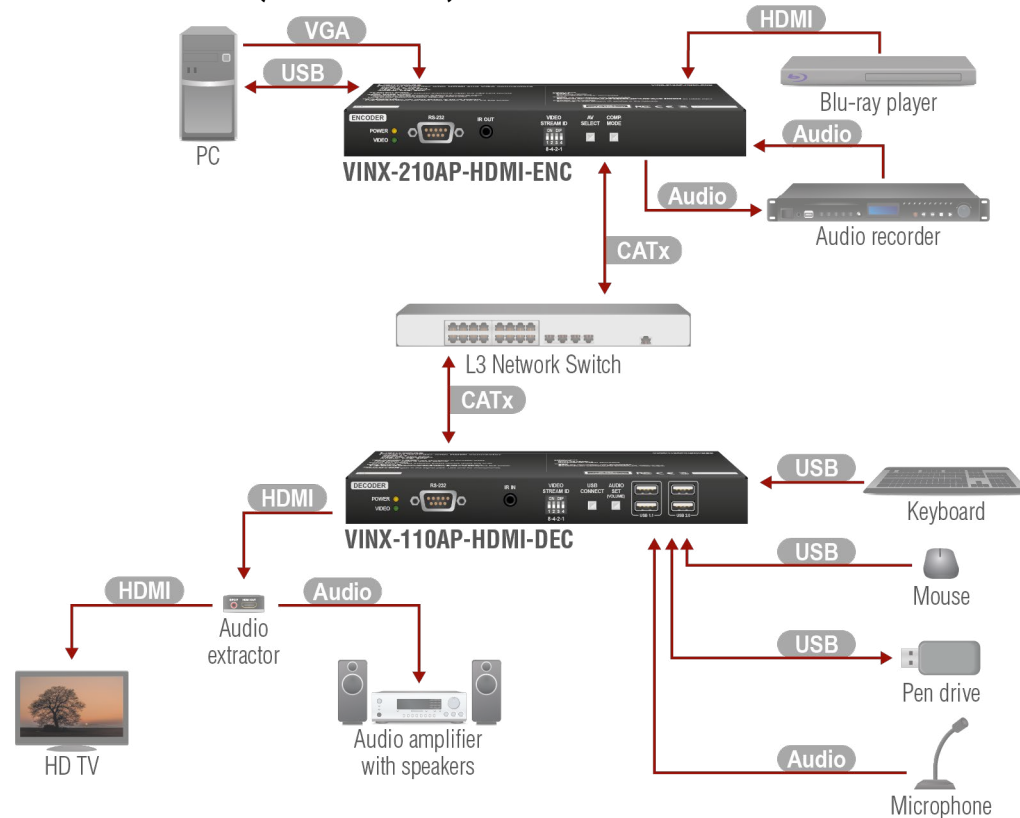

HDMI Connect an HDMI source device (e.g. a blu-ray player) to the HDMI input port of the Encoder. Connect a HDMI display device to the HDMI output port of the Decoder device. Optionally for audio extraction: connect an audio extractor device between the display device and the Decoder.

VGA Connect the desired VGA source (e.g. a computer) to the Encoder.

USB Optionally for USB extension: connect USB devices to the USB ports of the Decoder. Connect the desired host device (e.g. computer) to the Encoder via the USB type-B port.

Audio Optionally for audio extraction: connect an audio amplifier and speakers to the audio output port of the audio extractor.
Optionally for return audio transmission: connect the desired audio source device (e.g. a microphone) to the audio input port of the Decoder. Connect an audio recorder to the audio input and output ports of the Encoder, thus, you can both record and embed the audio signal in the HDMI stream.

CATx Connect CATx cables between the VINX devices and the L3 Switch. Applied cable shall be max. 100 m (CAT5 or CAT7).

Power For devices with local power only: connect the power cord of the supplied adaptor to the DC input first, then to the AC power socket.

3.5.4. Installation Checkpoints

The following tips increase the success of the installation:

- Use **CAT7 SFTP AWG23** cables for connecting the devices; the maximum allowed cable length is 100m.
- Supply the devices by **local adaptors** or by **PoE**; the feature is enabled on the RJ45 ports by default.
- **Power on** the devices as the final step.
- **Connect a computer** to the network to arrange the necessary settings easily (see the [Software Control Options](#) chapter).
- **Group the devices** by the DIP switch or via the built-in website.
- Make sure that each Encoder has a **unique video stream ID**. Set the same ID in the desired Decoders and Encoder.
- Check if the **desired input port** is selected to transmit.
- **Universal EDID** is emulated on the input ports that supports many common resolutions. If necessary, emulate a specific resolution by selecting a factory pre-programmed EDID.
- Select the **desired Decoder for USB** transmission in Multicast mode. (The USB connection is established automatically in Unicast mode.) Pay attention to the USB port types: USB 1.1 and USB 2.0 support.

4

Device Concept

The following chapter describes the features of the device with a few real-life examples.

- ▶ [VINX DEVICE CONCEPT](#)
- ▶ [VIDEO INTERFACE](#)
- ▶ [ANALOG AUDIO INTERFACE](#)
- ▶ [USB INTERFACE](#)
- ▶ [DANTE® AUDIO OUTPUT INTERFACE](#)
- ▶ [RS-232 INTERFACE](#)
- ▶ [CLEARTEXT LOGIN FEATURE](#)

4.1. VINX Device Concept

The key feature of the VINX series is the AV signal transmission from an Encoder to many Decoder devices. The video wall can be expanded at a later time, e.g. building a wall with 12 Decoders and add further 12 Decoders later. Another feature is the transmission of RS-232, USB and Infrared signals.







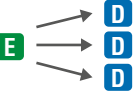

INFO: The USB, Serial, and IR data transmission works independently from the video signal presence.

Unicast Mode (Point-to-Point Connection)

A Decoder is connected to an Encoder device.

Multicast Mode (Point-to-Multi point Connection)

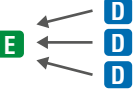
Many Decoder devices are connected to the same Encoder.

Signal	Unicast mode	Multicast mode
Video		
USB		
RS-232		
IR		
Analog audio*		

 Encoder  Decoder

* The Analog audio interface contains limitations, please see the details in the [Analog Audio Interface](#) section.

The USB transmission is available only at one Encoder-Decoder connection at the same time. The desired device can be activated by the front panel button or via the built-in website.

4.2. Video Interface

The following sections describe the modes of the video transmissions. When the necessary network settings are arranged, the following have to be set:

Video Stream ID Setting

DEFINITION: The **Video Stream ID** is a four-digit number sequence that identifies a certain stream generated by an Encoder and received by a Decoder.

The Video Stream ID creates the connection between an Encoder and a Decoder. Set the Video stream ID to the same value in the desired VINX devices:

- Use the **DIP switch** and set a value other than '0000', or
- Set the **DIP switch** to '0000' and define the ID via the **built-in web page**, see the [General Settings](#) section, or
- Set the **DIP switch** to '0000' and define the ID by sending the necessary **LW3 command** to the device, see the [Video Wall Settings](#) section.

INFO: The DIP switch state can be ignored by an LW3 command, see the [DIP Switch Enable](#) section.

Unicast/Multicast Mode Setting

DEFINITION: The **Unicast** mode is for **point-point** connection: assign an Encoder and a Decoder directly to each other. The devices can be connected directly or via the L3 switch.

DEFINITION: The **Multicast** mode is for **point-multipoint** connection: assign an Encoder and many Decoders to each other (L3 switch is a must in this mode).

Set the desired working mode of the extenders by:

- Selecting the mode via the **built-in web page**, see the [Advanced Settings](#) section, or
- Sending the necessary **LW3 command** to the device, see the [Setting the Working Mode \(Unicast/Multicast\)](#) section.

Delay in the Video Transmission

Due to the design of the devices, frame delay is in the signal transmission from the Encoder towards the Decoder. For further details, see the [Delay in the Video Transmission](#) section.

Supported Signal Formats

See the list of supported signal formats in the [Supported Resolutions](#) section.

ATTENTION! Encoder accepts **3840x2160@60Hz 4:2:0** signal but the local HDMI output of the encoder is able to transmit it. This resolution cannot be transmitted to the decoders.

4.2.1. One-to-one Video Transmission (Unicast Mode)

The Encoder and the Decoder devices are arranged in a LAN by connecting them to an L2 or L3 switch. By setting the extenders to Unicast mode, it is possible to extend the video signal via an Encoder to a dedicated Decoder.

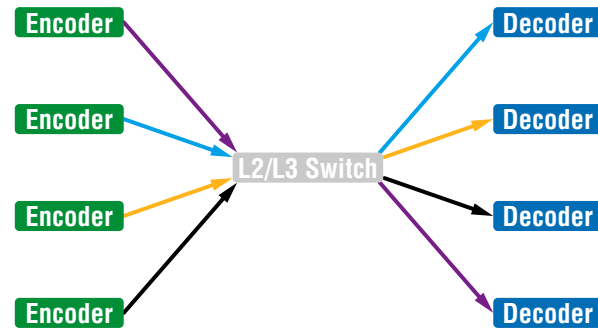

Displayed Images of the Sinks Connected to the Decoders:



INFO: The Encoder and the Decoder can be connected directly and set to Unicast mode. In this case there is no need an L2/L3 switch, but there is no way to communicate with other VINX devices.

4.2.2. One-to-All Video Transmission (Multicast Mode)

The Encoder and Decoder devices are arranged in a LAN by connecting them to an L3 switch. By setting the extenders to Multicast mode, a certain video can be extended from an Encoder to multiple Decoders.

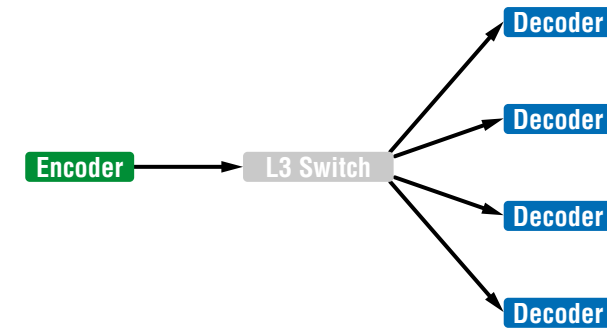

Video Wall Montage



Tiled Video Wall

4.2.3. Layout Examples

Multicast Mode with Video Wall

The Layout

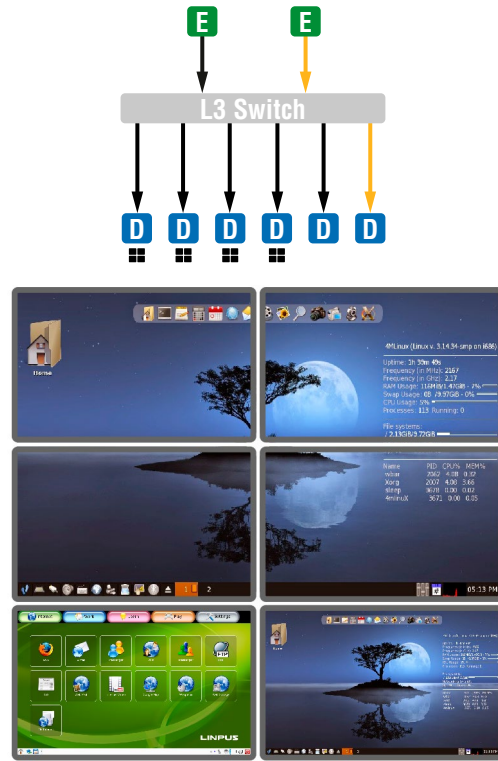

Features

- 2x2-sized video wall is defined and two further single displays are installed (bottom row).
- Any of the video signals can be displayed on the wall and on a single display device.
- The other video signal can be seen on the other display device.
- The video signal on the wall can be changed by using software tools (built-in web or LW3 protocol commands).

Legend

- E** Encoder
- D** Decoder
- The Decoder is assigned to a Video wall

Two Video Walls and Local Monitors with One Encoder

The Layout

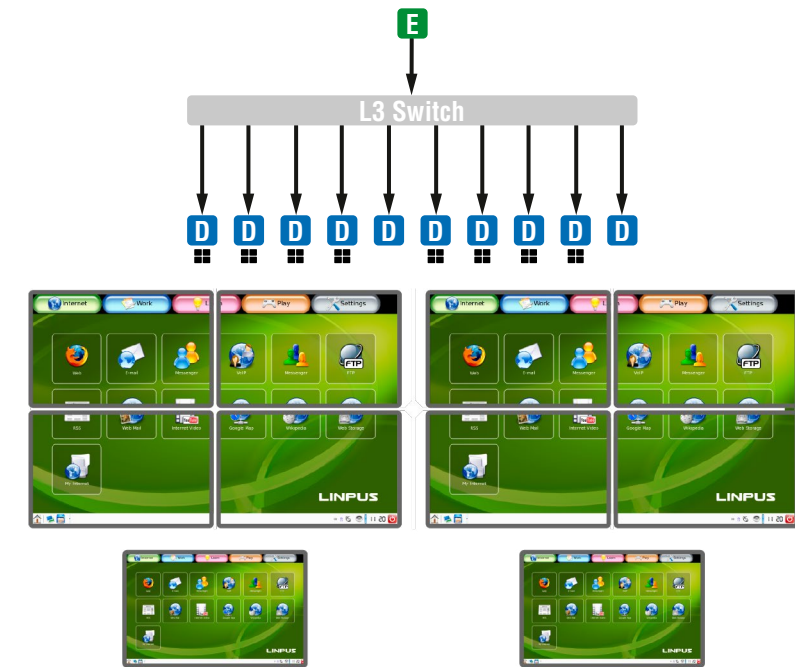

Features

- Two 2x2-sized video walls are defined and two further single displays are installed (e.g. the video walls and the local displays are located in different rooms).
- One video signal is displayed on the two video walls and on two local monitors.

Small View and Large View Combined in Multicast Mode

The Layout

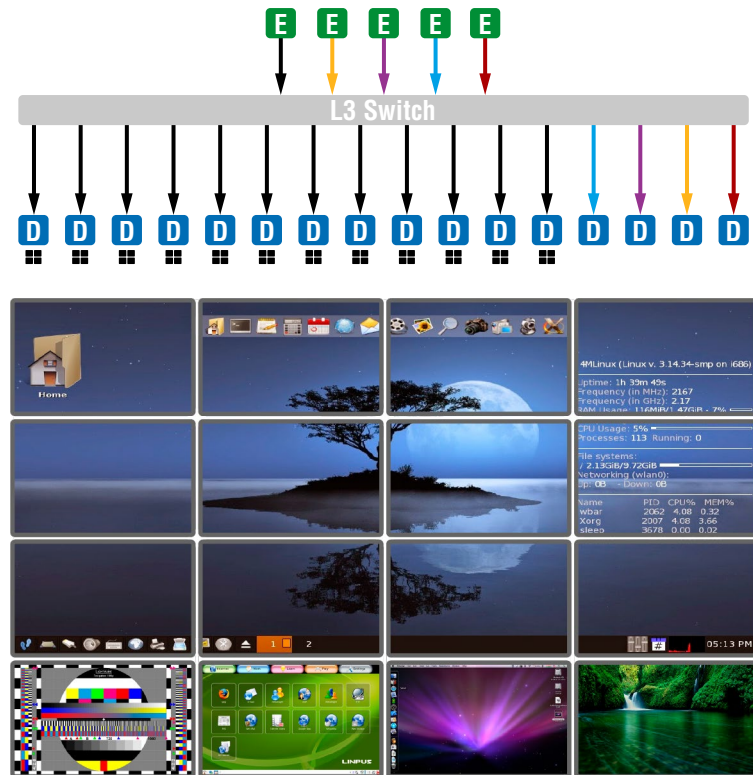

Features

- 3x4-sized video wall is defined and further four single displays are installed (bottom row).
- Any of the video signals can be displayed on the wall and on a single display device.
- The other video signals can be seen on the single display devices (bottom row).
- The video signal on the wall can be changed by using software tools (built-in web or LW3 protocol commands).

4.3. Analog Audio Interface

DIFFERENCE: The analog audio option is available only in VINX AP-series.

Unicast Mode

The Layout



Features

- The audio signal of the Media player is transmitted to the Audio amplifier (forward audio).
- The microphone signal is routed back to the Audio recorder device (return audio).

ATTENTION! The return audio (from the Decoder to the Encoder) is available only if the analog audio input is selected in the Encoder to transmit towards the Decoder. Thus, the other analog audio signal (MIC IN) connected to the Decoder can be routed back to the Audio output of the Encoder.

ATTENTION! The microphone input port applies a fixed bias to feed the connected electret (condenser) microphone. Thus, it is not suitable for dynamic microphones that do not contain isolation or an impedance matching transformer. (Danger of damage to the microphone.)

Multicast Mode

The Layout



Features

- The analog audio signal can be selected in the Encoder and would be embedded in the video stream in the Decoder.

INFO: If there is no video input, the encoder shall still transmit the audio from its analog audio input. The destination shall be the decoders that are subscribed to the Video Stream ID set in the encoder.

4.4. USB Interface

USB 1.1 and USB 2.0 data transmission operates between an Encoder and a certain Decoder device. Connect the host device (e.g. a computer) to the Encoder and the USB devices to the Decoder. Supported USB devices:

- **USB HID devices:** keyboard, mouse, presenter.
- **Mass storage devices:** USB flash drive, external hard drive.

ATTENTION! The USB ports are not recommended for time-sensitive applications (e.g. webcam).

The maximum data transmission rate of USB 2.0 ports is 5 MBit/s.

The transmission works in Unicast and Multicast mode as well, but in case of the latter, the desired Decoder has to be selected by any of the following ways:

- Pressing the **Mode** button on the front panel for less than three seconds (the connected display device will show **Starting USB**, the other Sinks will show **Stopping USB** on the screen),
- Pressing the **Acquire USB connection** button in the Advanced tab on the built-in web page (see the [USB Settings \(Multicast Mode\)](#) section), or
- Sending an LW3 command to the desired Decoder.

The USB devices connected to the other Decoders will be still powered, but the data transmission is suspended.

ATTENTION! USB 1.1 ports can be used for the stream changing, see the [Keyboard Shortcuts](#) section.

ATTENTION! The active Decoder works like an extended USB hub connected to a computer. Pay attention to the storage device to remove safely before unplugging it or interrupting during a disc operation.

INFO: The USB transmission is automatically enabled between the Encoder and the Decoder in Unicast mode.

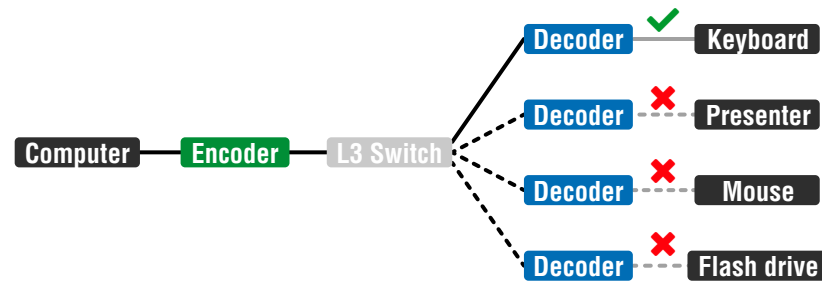

USB Transmission between an Encoder and a Decoder

4.5. Dante® Audio Output Interface

DIFFERENCE: The following section refers to the VINX-120AP-HDMI-ENC-DNT model only.

VINX-120AP-HDMI-ENC-DNT variant contains a special module that allows de-embedding the audio stream of the incoming HDMI signal and transmitting as a 2-channel Dante® or AES67 source over the dedicated RJ45 connector. *#dante #audio*

ATTENTION! Analog audio input signal cannot be routed to the Dante® audio output.

Port Diagram of VINX-120AP-HDMI-ENC-DNT

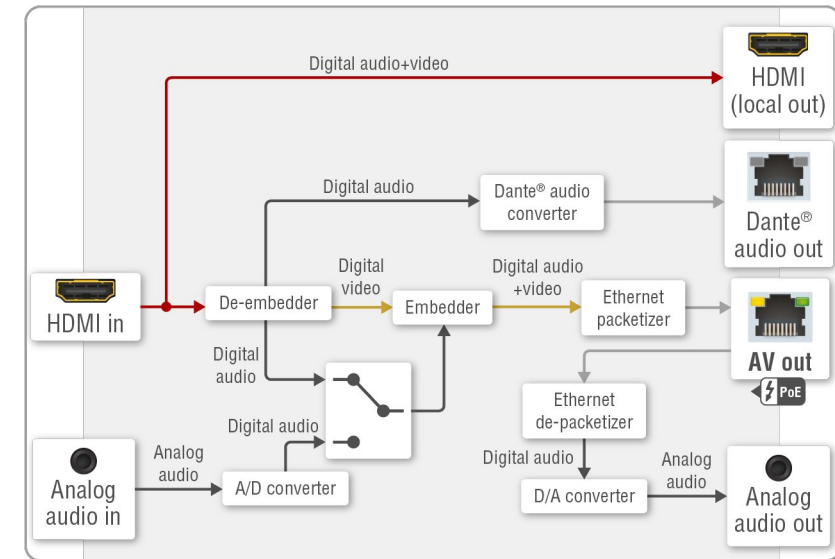

* The analog audio transmission (opposite direction than the video stream) is available only in Unicast mode.

Supported Audio

Input audio type	Signal support
2-ch LPCM **	supported
Multichannel	not supported
Compressed DTS/Dolby	not supported

** The supported sample rates are 44.1, 48, and 96 kHz.

Dante® is a registered trademark of Audinate Pty Ltd.

Important Notes

- It is essential to have the **right QoS settings** in the network switch where the Dante® audio is connected to. See the details in the [Application Note \(LW-AN-001\)](#) section.
- Even if the Audio network and the video network are **separated** on distinct LANs (with 2x RJ45 connectors), the Dante® audio can be transmitted over the same network that is used for the VINX video streaming.
- The **AES67 mode** is supported by the VINX extender, and can be set in the Dante® Controller software.
- Multichannel or encoded audio** format cannot be de-embedded. In this case, no audio is sent to the Dante® network.
- Limitation:** VINX video stream and Dante® audio stream is **not in sync**; Dante® audio is 1.1 frame early. The delay occurs during the video transmission from the Encoder towards the Decoder; see more details in [Delay in the Video Transmission](#) section.
- Dante® audio cannot be received by the VINX device.

Settings and Signal Routing

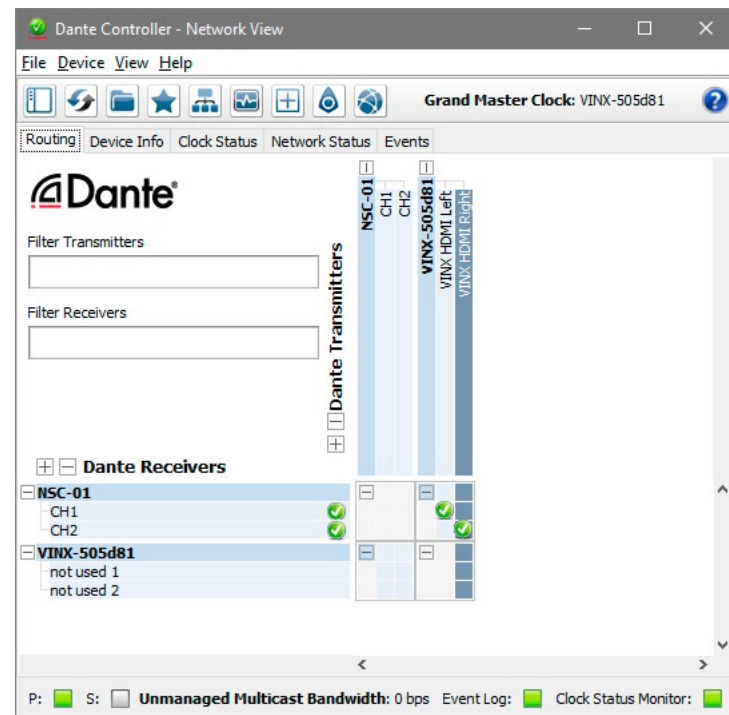

All these features are available in the Dante Controller software, which can be downloaded from the manufacturer's web page:

<https://www.audinate.com/products/software>

Device Settings

The discovered Dante®-compatible devices are displayed with middle-blue color. Double-click on the name to open the device settings.

The default device name is:

VINX-<Dante_MAC_address_last 6_characters>

It can be changed under Device config tab. Similarly, the channel names can also be changed. NSC-01 is another device with Dante® audio interface.

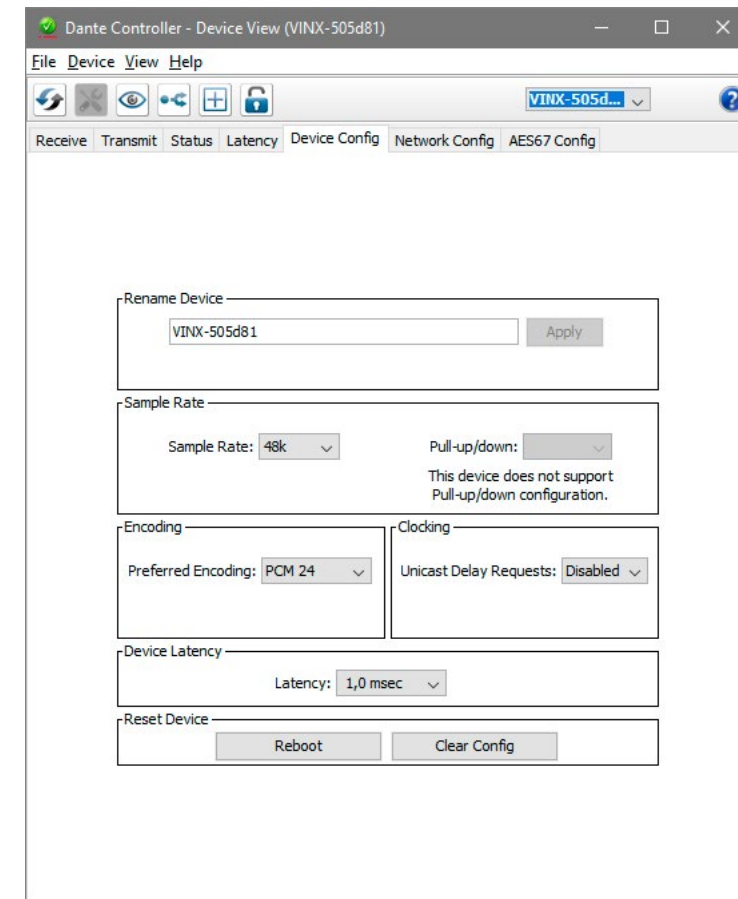

Press the  button to identify the device: the LEDs of the RJ45 connector will blink six times in red.

4.6. RS-232 Interface

DIFFERENCE: The WP-VINX-110P-HDMI-ENC model does not have a serial port, thus this feature is unavailable with the wall plate.

Serial data transmission works between an Encoder and all the connected Decoders that have the same Video Stream ID. This transmission is independent from the current working mode (Unicast/Multicast). To connect serial devices, please use the cables supplied with the extenders.

ATTENTION! The serial data is transmitted only if video is transmitted between the affected devices.

Pass-through Mode

DEFINITION: The **Pass-through mode** means fully transparent bidirectional data transmission from an RS-232 port of a VINX Extender to an RS-232 port of a VINX Decoder – and Vice versa.

All data received from the serial ports of the Decoders is transmitted to the serial port of the Encoder and vice versa: the data received from the serial port of the Encoder is transmitted to the serial ports of all connected Decoders.

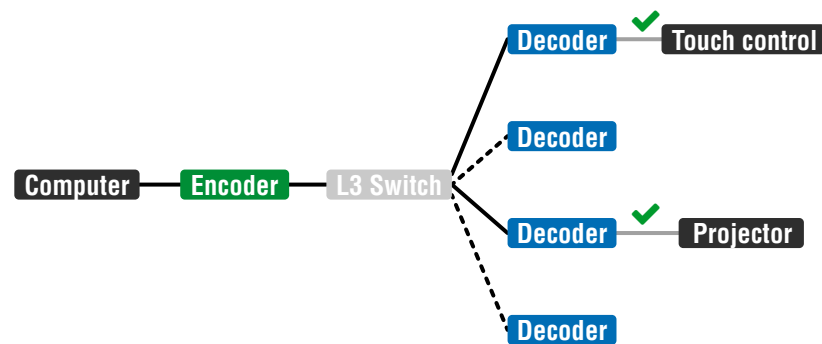

RS-232 Data Transmission (Pass-through mode)

Please note that transmitting data between two Decoders is not possible; see the figure above: sending serial data from the Touch Control to the Projector is not possible.

ATTENTION! The data transmission works only if the serial port parameters are set to the same values in all devices: serial data sender/receiver and the VINX Encoder and Decoder devices.

Command Injection Mode

DEFINITION: The **Command Injection mode** is like an RS-232–TCP/IP bidirectional converter. The mode allows data transmission between a TCP/IP device and a serial device.

When a device is connected to the network (e.g. TCP/IP connection from a computer) and a serial device is connected to the RS-232 port of a VINX device, they can communicate with each other.

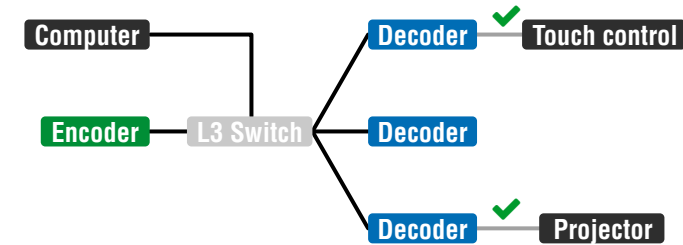

RS-232 Data Transmission (Command Injection mode)

The mode can be enabled as described in the [Setting the RS-232 Port Mode](#) section.

4.7. Cleartext Login Feature

DIFFERENCE: This feature is available from firmware v3.1.0.

The **Cleartext Login** tool allows setting a password for login, thus the device will not accept any command coming from an interface (LW3, Ethernet, etc...), only the device type and the serial number can be queried without login.

By default, Cleartext login is disabled in the devices.

INFO: In case of VINX devices RS-232 interface is not protected by the password, but the Built-in web is.

The Login feature is available in the LDC under the Main Settings menu.

For more information, see the Cleartext Login (Login Settings) section.

5

Software Control Options

The VINX extenders allow setting all the parameters via a user-friendly interface. Open a web browser (Google Chrome or Mozilla Firefox is highly recommended) and connect to the extender to access the parameters and settings. The other option is to use the Lightware Device Controller (LDC) software and connect to the device without a web browser. The features are described in the coming sections.

- ▶ [SOFTWARE CONTROL MODES](#)
- ▶ [CONNECTING USING LIGHTWARE DEVICE CONTROLLER](#)
- ▶ [CONNECTING VIA THE BUILT-IN WEB PAGE](#)
- ▶ [MAIN SETTINGS \(ENCODER\)](#)
- ▶ [MAIN SETTINGS \(DECODER\)](#)
- ▶ [CROSSPOINT MENU](#)
- ▶ [EDID MENU](#)
- ▶ [ADVANCED SETTINGS](#)
- ▶ [VIDEO WALL SETUP](#)

5.1. Software Control Modes

The VINX device can be controlled by the following ways:

- Using the **built-in web page**,
- Using the **Lightware Device Controller (LDC)** software, or
- Sending **LW3 commands** (detailed in the [Programmer's Reference](#) chapter).

Built-in web page vs. LDC

The LDC and the built-in web page shows the same content, but there are some minor differences:

Function	Built-in Web	LDC
Platform	Mozilla Firefox, Google Chrome	Windows, mac OS
Installation	Web browser needed only	Required
Firmware update	✓	-
Device discovery	-	✓

ATTENTION! If you prefer LDC, make sure the software is up-to-date. If a new VINX firmware is released, the LDC will show the changes only if the program is also updated.

INFO: Even though the LDC is introduced briefly, this chapter contains screenshots using the built-in web page.

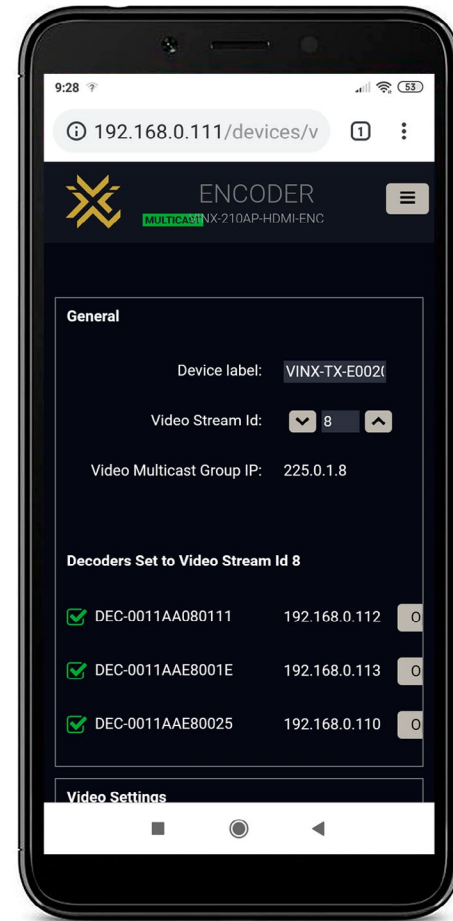

The Main window – displayed on a mobile device

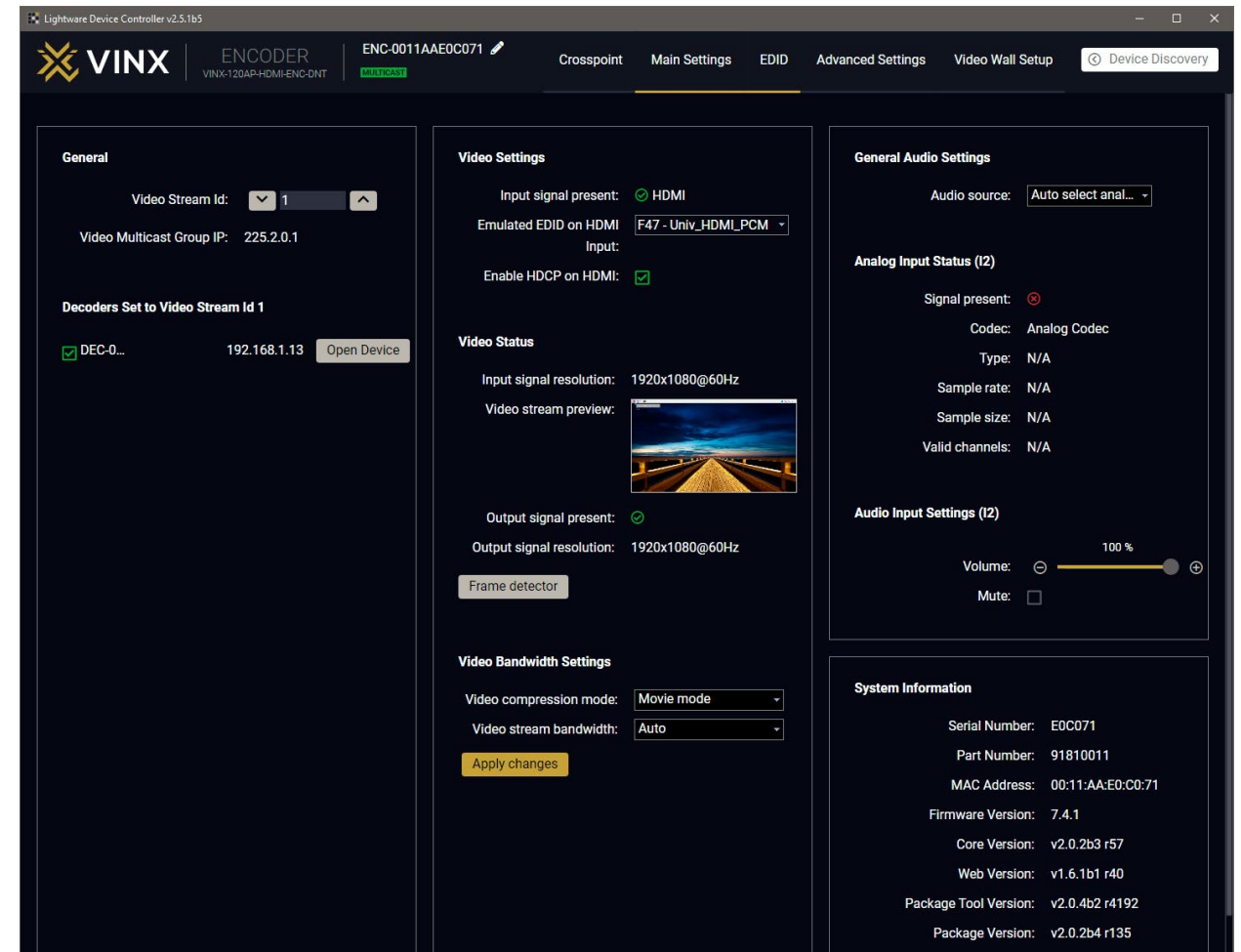

The Main window – displayed in LDC

5.2. Connecting Using Lightware Device Controller

One option for controlling is to use the well-known LDC software. Download it from www.lightware.com and install. After the installation, the Windows and the macOS applications have the same look and functionality. This type of the installer is equal with the Normal install in case of Windows and results in an updateable version with the same attributes.

Installation for Windows OS

Step 1. Run the installer. If the User Account Control drops a pop-up message, click **Yes**.

Step 2. During the installation you will be prompted to select the type of the installation: **normal** and the **snapshot** install:

Normal install	Snapshot install
Available for Windows and macOS	Available for Windows
The installer can update only this instance	Cannot be updated
Only one updateable instance can exist for all users	Different versions can be installed for all users

Comparison of the Installation Types

ATTENTION! The minimum display resolution is 1280x720.

ATTENTION! Using the Normal install as the default value is highly recommended.

Installation for macOS

ATTENTION! Please check the firewall settings on the macOS device. LDC needs to be added to the exceptions of the blocked software for proper operation.

Mount the DMG file by double clicking on it and drag the LDC icon over the Applications icon to copy the program into the Applications folder. If you want to copy the LDC into another location, just drag the icon over the desired folder.

5.2.1. Updating the LDC

When the **Device Discovery** window appears automatically, the program checks the available updates on Lightware's website and opens the update window if LDC updates are found (default setting).

Set the desired update setting in the **Options** section. When the **Check for updates automatically** option is marked, the LDC tries to find a new version after startup.

INFO: The Update window can be opened manually by clicking on the question mark and the Update button.

5.2.2. Running the LDC

Launch the LDC software. The **Ethernet** tab consists of two lists:

- **Favorite Devices:** You can add any Lightware device that is connected via Ethernet and without needing to browse all the available devices. Devices can be added by pressing the **Add** button, or marking the desired device by the ★ symbol in the **All Devices** list.
- **All Devices:** All Lightware devices are listed that are available in the connected network.

Select a device and click on the green **Connect** button, or just double-click on it.

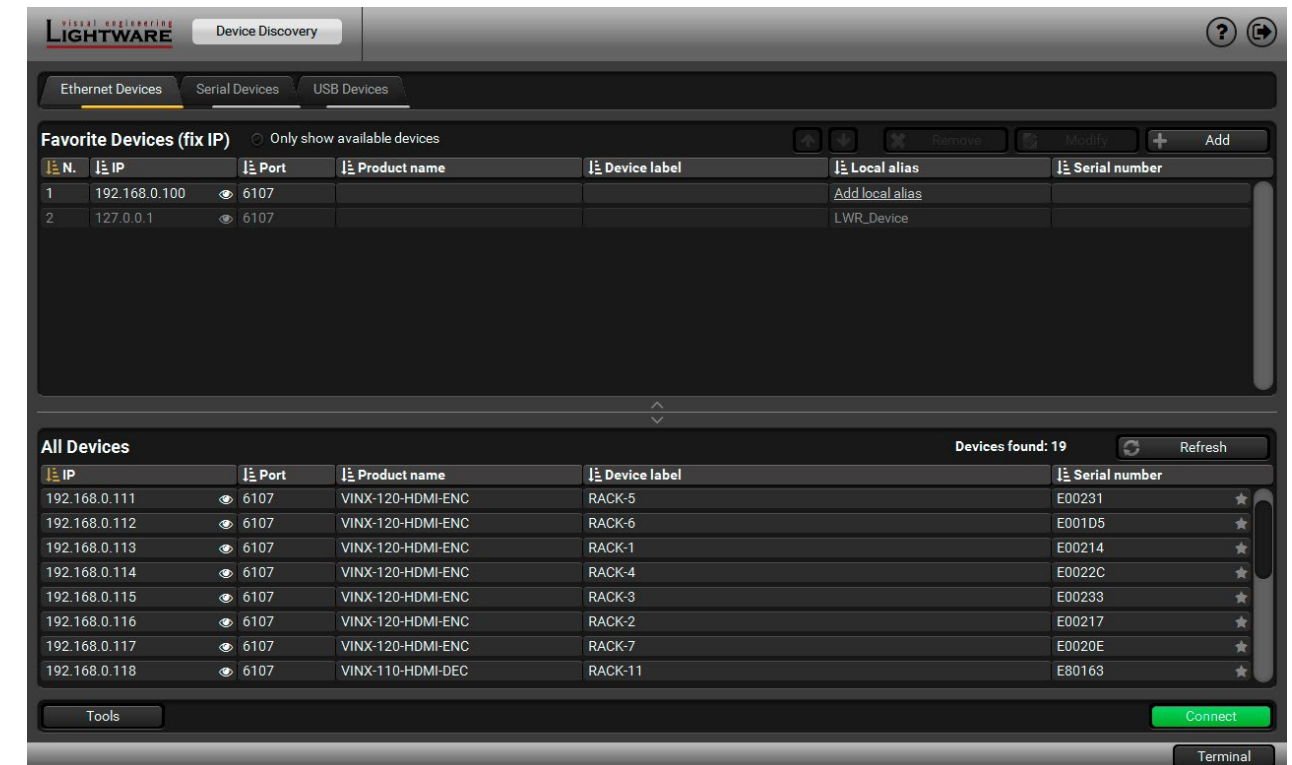

Device Discovery Window

Command Line Parameters

The common way to start the software is to double-click on the LDC icon, but you can use command line parameters for special functions as follows.

Direct Connection to a Known IP Address

The LDC can be connected to a device with a defined IP address directly; in this case, the Device Discovery window is not displayed. Apply the command line parameters as follows (for VINX devices – and for LW3 devices in general – use the port number 6107):

Format: `LightwareDeviceController -i <IP_address>:<port>`

Example: `LightwareDeviceController -i 192.168.0.20:6107`

Adjusting the Zoom

The window can be zoomed to a specific value to fit to the resolution of the desktop (higher/lower). '1' is the default value (100%).

Format: `LightwareDeviceController -z <magnifying_value>`

Example: `LightwareDeviceController -z 1.2`

ATTENTION! The last set value is stored and applied when LDC is started without a parameter

Further Tools

The **Tools** menu contains the following options:

- **Log Viewer:** The tool can be used for reviewing log files that have been saved previously.
- **Create EDID:** This tool opens the Easy EDID Creator wizard, which can be used for creating unique EDIDs in a few simple steps. Functionality is the same as it is in the Easy EDID Creator.
- **Demo Mode:** This is a virtual MX-FR17 matrix router with full functionality built into the LDC. Functions and options are the same as of a real MX-FR17 device.

The **Terminal** window is also available by pressing its button on the bottom.

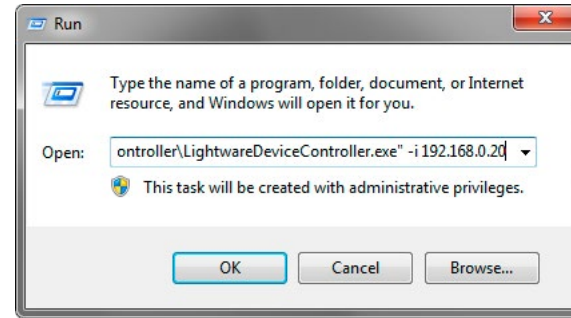

5.3. Connecting via the Built-in Web Page

ATTENTION! The supported web browsers are Google Chrome and Mozilla Firefox.

Another option for controlling the VINX device is to open the built-in web page. It is enough to connect to one device, the others can be discovered easily. If you successfully connected to an Encoder, all the other counterpart devices will be listed in the **Main settings** tab (General section). Vice versa: when connected to a Decoder, the available Encoders are listed in the **Main settings** tab.

If You do not Know the IP Address

You can do any of the followings:

- Connect a monitor/projector to a Decoder; the default VINX screen will show its IP address.
- Find the MAC address of the desired device (located on the top of the extender) and launch the web browser:
 - a) In case of a **Decoder**, type the following in the address line:
<http://LWR-clientAABBCCDDEEFF.local>
 - b) In case of an **Encoder**, Type the following in the address line:
<http://LWR-gatewayAABBCCDDEEFF.local>

AABBCCDDEEFF is the MAC address of the device (without hyphens) – which can be seen on the housing of the extender.

The Default IP Address

The default IP Address Setting is DHCP with Auto IP and works as follows:

- **If there is a DHCP server** in the network: the VINX device got an IP address from the DHCP server. Make sure the control PC is connected to the same network.
- **If there is no DHCP server** in the network: the VINX device generates an IP address in the 169.254.x.x range (AutoIP). Set the IP address of the control PC to match with this range (with subnet mask 255.255.0.0).

After a successful connection you can change the IP settings.

5.4. Main Settings (Encoder)

5.4.1. General Settings

Unicast Mode *#unicast*

The Video stream ID is not only used in Multicast mode. To assign an Encoder and a Decoder in Unicast mode, set the same Video stream ID in both devices.

Grouping the VINX Extenders *#multicast*

Video Stream ID *#videostreamid #streamid*

The current ID number is shown. The following rules are defined to avoid Video Stream ID conflicts:

- When the DIP switch is in **0000** position, the SW setting will be valid, or else the HW setting (DIP switch) will be valid.
- When the DIP switch is set back to **0000**, the SW setting will inherit the ID (the previous DIP switch value).
- SW setting and HW setting can be combined within the group, but in this case the DIP switch value will determine the common Video Stream ID.

INFO: The DIP switch state can be ignored by an LW3 command, see the [DIP Switch Enable](#) section.

Decoder Assignment

The list contains the VINX devices that are available within the same subnet. Mark the desired devices to set the same ID.

Device Label *#label #devicelabel*

A unique name (up to 32 ASCII characters) can be set that will be visible when the given device is listed in the built-in web page of other VINX devices. Furthermore, the name is listed when browsing the client list of a DHCP server.

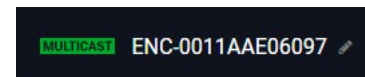

ATTENTION! It might happen that two or more Encoders are installed in the same system with the same Video Stream ID. This would result in display problems (e.g. more mouse cursors are displayed when desktop images are shown). Check the Video Stream ID settings of the Encoders.

ATTENTION! The **Video wall setup** submenu is not displayed on mobile devices in most cases due to the limitation of these screens.

TIPS AND TRICKS: Press the VINX drawing in the top left corner to navigate back to the Device Discovery window.

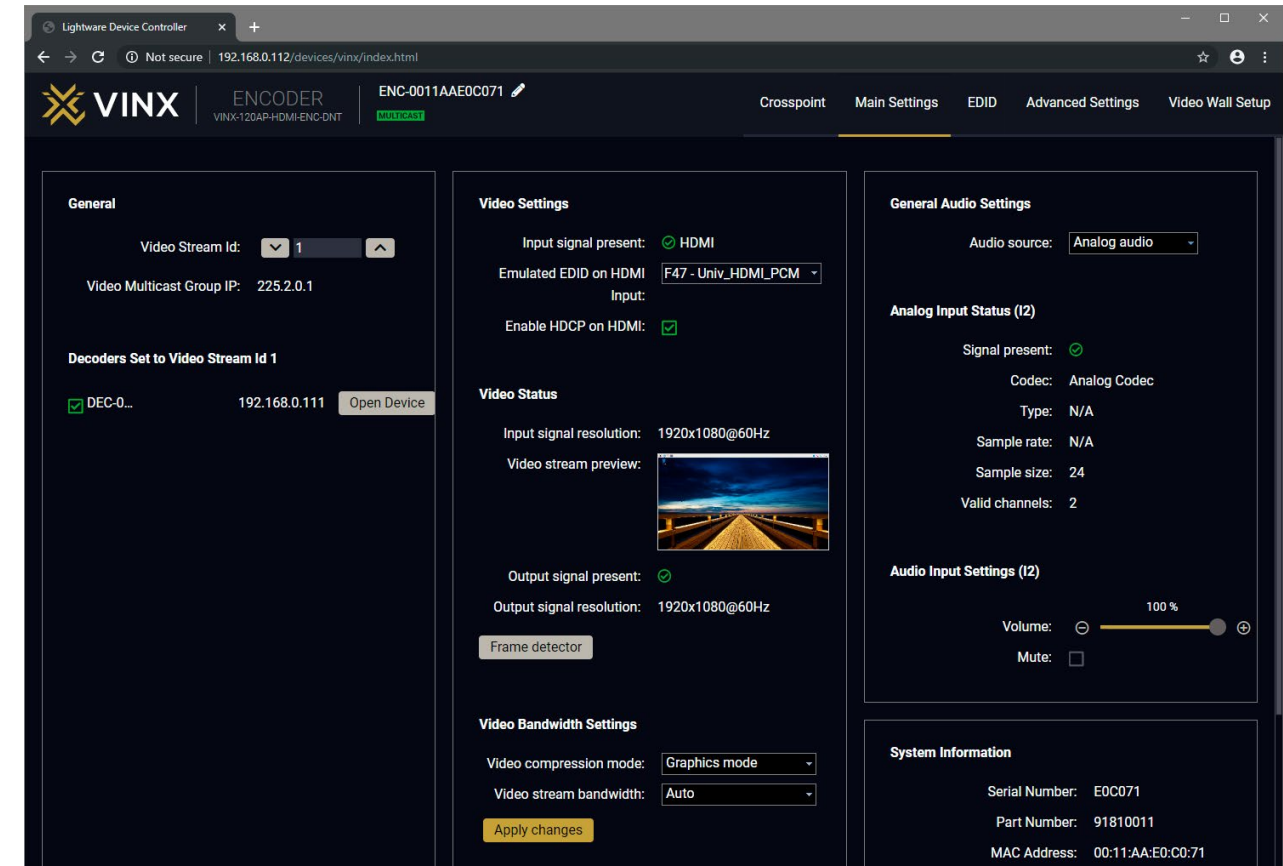

The Main Window of the Built-in Web Page (Encoder) – Displayed on a Computer

Symbol Legend

- UNICAST** The current working mode
- MULTICAST** The current working mode
- DIP SWITCH** The Video stream ID is set by the DIP switch
- The given Decoder belongs to a video wall
- Displaying the Main Menu (if there is not enough space)
- Connect** Connecting to another device (opened in new tab)

5.4.2. Cleartext Login (Login Settings)

DIFFERENCE: This feature is available from firmware v3.1.0.

This cleartext login tool allows setting a password for login, thus the device will not accept any command coming from a control interface (LW3, Ethernet, etc...) without login. The device will be visible in the Device Discovery window (as the device type and the serial number can be queried without login) but connection can be established only after successful login. The login is valid until a TCP socket break in case of Ethernet connection. *#login*

ATTENTION! If the login is enabled, the built-in miniweb will also require the password upon entering.

INFO: The login password is erased and the login protection is disabled when restoring the factory default values.

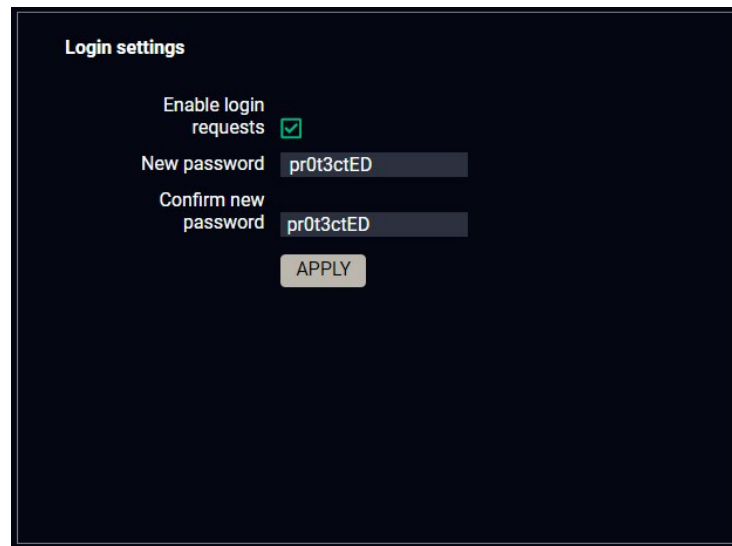

The password may contain uppercase (A-Z) and lowercase (a-z) letters of the English alphabet, as well as numbers (0-9). The minimum length of a password is four characters.

ATTENTION! Make sure to tick in the **Enable login requests** option before clicking on the **Apply** button, otherwise the login function will remain inactive.

This function is also available on Decoders' interface with the same conditions.

5.4.3. Video Status and Settings

The properties of the incoming and outgoing video signals are displayed in the following sections.

Video Settings *#hdcp*

- The emulated EDID can be selected (see the [EDID Operations](#) section).
- Setting the HDCP status on the input:
 - **Enable:** the connected source will detect the Encoder to be **HDCP-compliant**.
 - **Disable:** the connected source will detect the Encoder to be **not** HDCP-compliant. Thus, if the content allows it, the signal will not be HDCP encrypted.

Video Status *#status*

- Input signal presence and **Video stream preview**. The image is updated approx. every third seconds.
- Displaying the **Frame Detector** in a new window, see the [Frame Detector](#) section.

ATTENTION! If the HDCP setting is changed, a window will pop up to confirm, as the device will be restarted to apply the settings.

ATTENTION! The EDID information cannot be read by the source attached to the HDMI input of an Encoder if HDCP is disabled on the input. This may stop the video transmission in case of certain source devices.

Video Source Selection *#source*

DIFFERENCE: The feature is available in VINX-210AP-HDMI-ENC device only.

- The desired video source can be selected from the drop-down menu: **HDMI / VGA / Auto**.
- **Auto mode:** the first connected source shall remain active as long as signal is present on the respective input. If sync is lost for at least 3 seconds, a switch over to the other source shall occur. No automatic switch back to the original input shall occur when the signal is restored.

Video Bandwidth Settings

Compression Mode *#compression*

When the network bandwidth is not enough to transmit the video signal, the following modes are available in the Encoder:

- **Movie mode** (Lower image quality @ Less bandwidth): The image quality is adjusted to the available bandwidth. If the bandwidth is decreased, the image quality will be lower, but the video streaming will be continuous.
- **Graphics mode** (Best image quality @ High bandwidth): The image quality is kept at a high level. If the bandwidth is decreased, the image quality does not change, but frame drop may appear.

The setting takes effect when the available bandwidth is less than required.

Video Stream Bandwidth `#bandwidth`

A specific bandwidth limitation can be set in the Encoder that **affects only the video signal** transmission. The following values are available:

Auto / 10 Mbps / 50 Mbps / 100 Mbps / 150 Mbps / 200 Mbps

The **Auto** setting is the default value, which means the available bandwidth is determined according to current network traffic.

ATTENTION! If the Bandwidth setting is changed, a window will pop up to confirm, as the device will be restarted to apply the settings.

5.4.4. Audio Settings

The General audio settings allow the selection of the desired audio source and setting the volume of the output signal.

Auto select analog mode: the Analog audio input port is selected when a plug is connected.

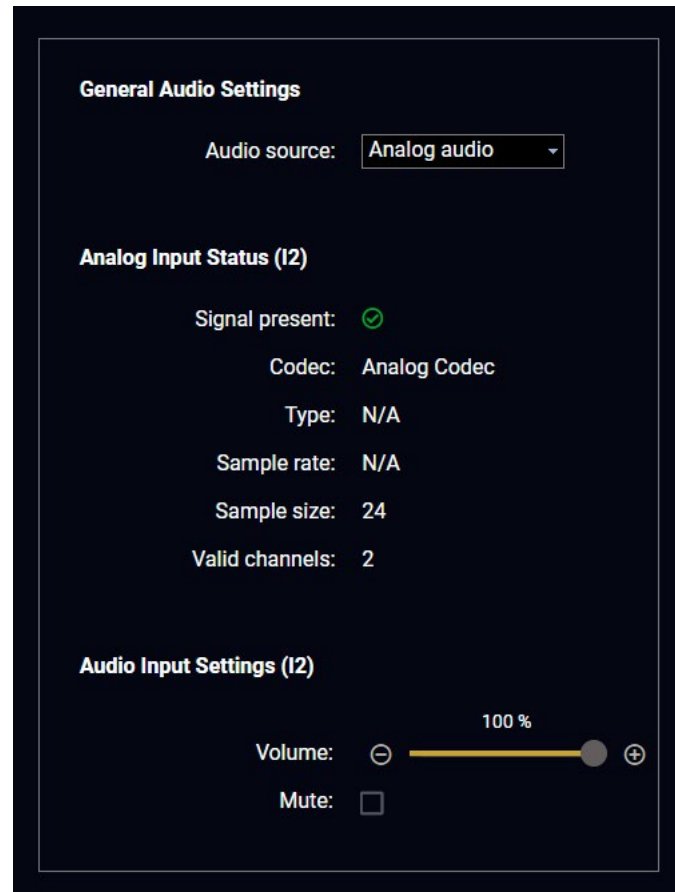

`#audio #analogaudio #volume #mute #unmute`

5.5. Main Settings (Decoder)**5.5.1. General Settings****Unicast Mode** `#unicast`

The Video stream ID is not only used in Multicast mode. To assign an Encoder and a Decoder in Unicast mode, set the same Video stream ID in both devices.

Grouping the VINX Extenders `#multicast`**Video Stream ID** `#videostreamid #streamid`

The current ID number is shown. The following rules are defined to avoid Video Stream ID conflicts:

- When the DIP switch is in **0000** position, the SW setting will be valid, or else the HW setting (DIP switch) will be valid.
- When the DIP switch is set back to **0000**, the SW setting will inherit the ID (the previous DIP switch value).
- SW setting and HW setting can be combined within the group, but in this case the DIP switch value will determine the common Video Stream ID.

INFO: The DIP switch state can be ignored by an LW3 command, see the [DIP Switch Enable](#) section.

Encoder-Decoder Assignment

The list contains the VINX encoders available in the same subnet. Mark the desired devices to set the same ID.

Device Label `#label #devicelabel`

A unique name (up to 32 ASCII characters) can be set that will be visible when the given device is listed in the built-in web page of other VINX devices. Furthermore, the name is listed when browsing the client list of a DHCP server.

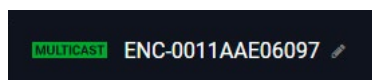

ATTENTION! It might happen that two or more Encoders are installed in the same system with the same Video Stream ID. This would result in display problems (e.g. more mouse cursors are displayed when desktop images are shown). Check the Video Stream ID settings of the Encoders.

ATTENTION! The **Video wall setup** submenu is not displayed on mobile devices in most cases due to the limitation of these screens.

5.5.2. Video Status and Settings

The content of the window is almost the same as in the case of the Encoder. The Video Status Information is filled with details when valid signal is detected and a sink is connected. The addition is the **Scaler settings**, which is also available on the **Advanced Settings** page.

DEFINITION: Scaling a video signal means changing the image resolution. The new resolution may change the aspect ratio and/or the appearance of the image. *#status*

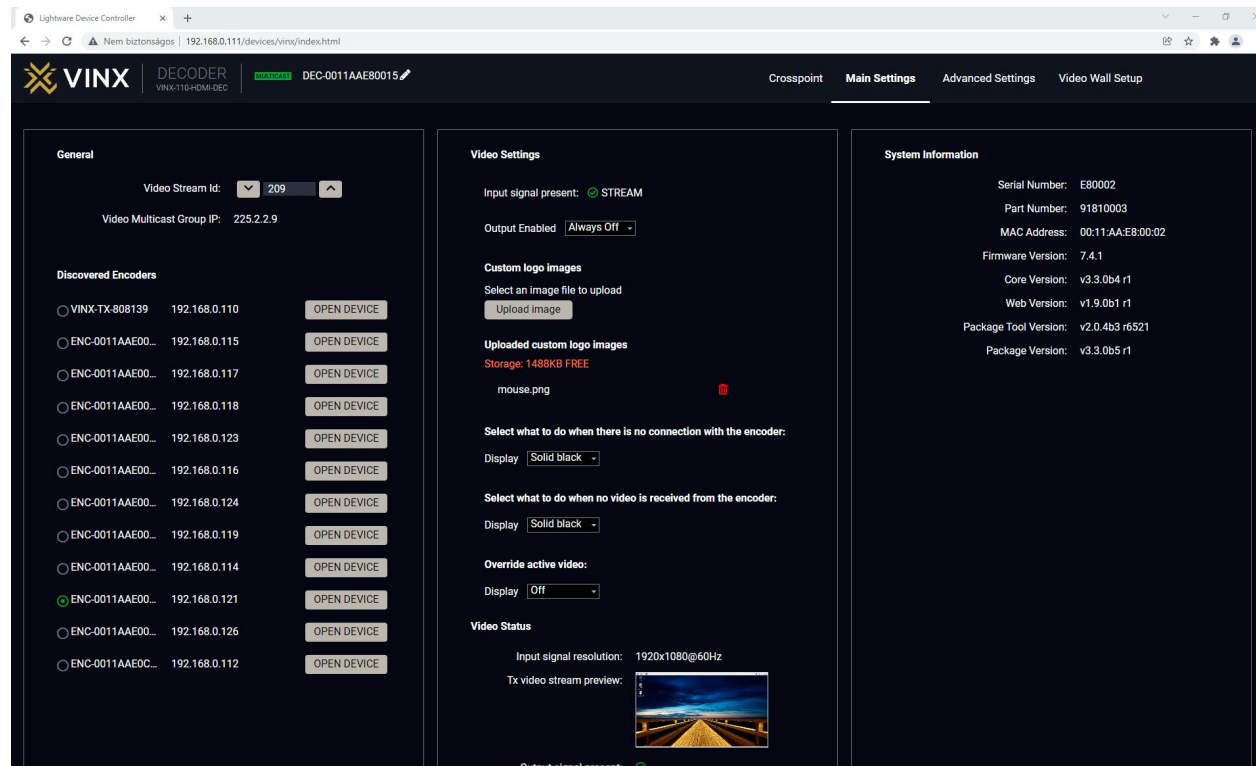

The Main Window of the Built-in Web Page (Decoder) – Displayed on a Computer

No Signal Screen

VINX decoders have a built-in screen that is sent to the output when there is no incoming signal on that particular decoder. It can be changed in this section to show a black screen.



The default VINX "no signal screen"

ATTENTION! Press the **Apply** button to apply the new setting, which makes the device reboot.

Uploading a Custom Logo

Users can upload custom logo images to be shown on the screen when there is no incoming signal on that particular decoder.

To upload a file, click on the **Upload image** button, browse the file in the pop-up window, and click open.

The name of the file to be uploaded may contain only letters of the English alphabet (A-z) and numbers (0-9).

The device has 1.5 MB free space for this feature. The current amount of free space available is displayed in this section in red. You can upload any number of files within the limits of the amount of free space available.

Additionally, you can set what to display when there is no connection with the encoder, when there is no incoming video signal from the encoder, or you can override the active video using the drop-down menus.

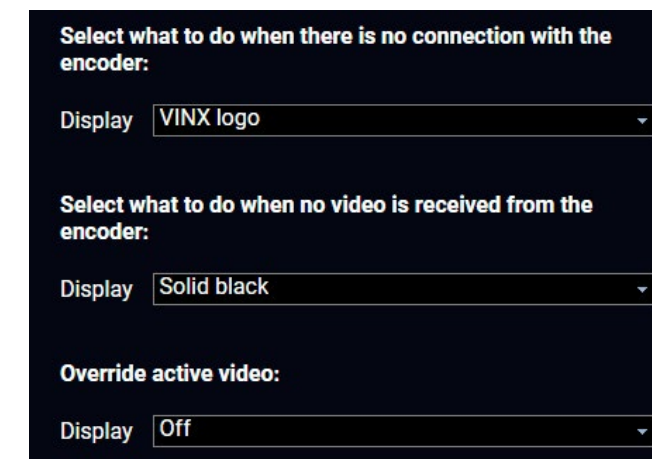

Video Output Setting

DIFFERENCE: The video output port of the decoder can be disabled from firmware package v3.3.1. In case previous firmware packages the video output is always enabled and cannot be modified. *#new*

Output Enabled

- **Auto:** the HDMI +5V is enabled and AV signal is transmitted on the output port if any signal is transmitted from the encoder.
- **Always off:** the HDMI +5V is disabled and the output port does not transmit AV signal.

Scaler settings

The outgoing video signal can be set in each Decoder separately. *#scaler*

Output Scaling

- **Pass-through:** the resolution, refresh rate and the type of the outgoing and incoming signals are the same.
- **Auto detect from EDID:** the resolution of the outgoing video is scaled to meet with the preferred timing coming from the EDID of the connected display device.
- **Custom:** a wide range of the scaling resolutions are available from 640x480 till 4096x2160.

ATTENTION! The scaler has the following limitations:

- Can't upscale from sources having a horizontal resolution greater than 1920 pixels. For example, 3840x2160 to 4096x2160 is not supported.
- Can only do horizontal+vertical half downscale. For example: 4096x2160 to 1920x1080: 128 horizontal pixels will be missing ($4096/2 - 1920 = 128$).

When scaling down, the Receiver can only go down to a minimum of half of the input resolution. For example, 3840x2160p (4K) can be scaled down to a minimum of 1920x1080p. Scaling 4K to 720p will not display correctly. Scaling up does not have this limitation.

Output Standard

When the Output scaling is set to **Custom**, the outgoing signal can be set to **DVI** or **HDMI**.

Picture Rotation/Flip *#rotation #flip*

The following options are available:

- No rotation,
- Flip vertically
- Flip horizontally
- Rotate by 90 / 180 / 270 degrees

Frame Detector

The ports can show detailed information about the signal, like blanking intervals and active video resolution. This feature is a good troubleshooter if compatibility problems occur during system installation. Lightware's Frame Detector function works like a signal analyzer and makes it possible to determine the exact video format that is present on the port, thus helping to identify many problems. E.g. actual timing parameters may differ from the expected and this may cause some displays to drop the picture. *#framedetector*

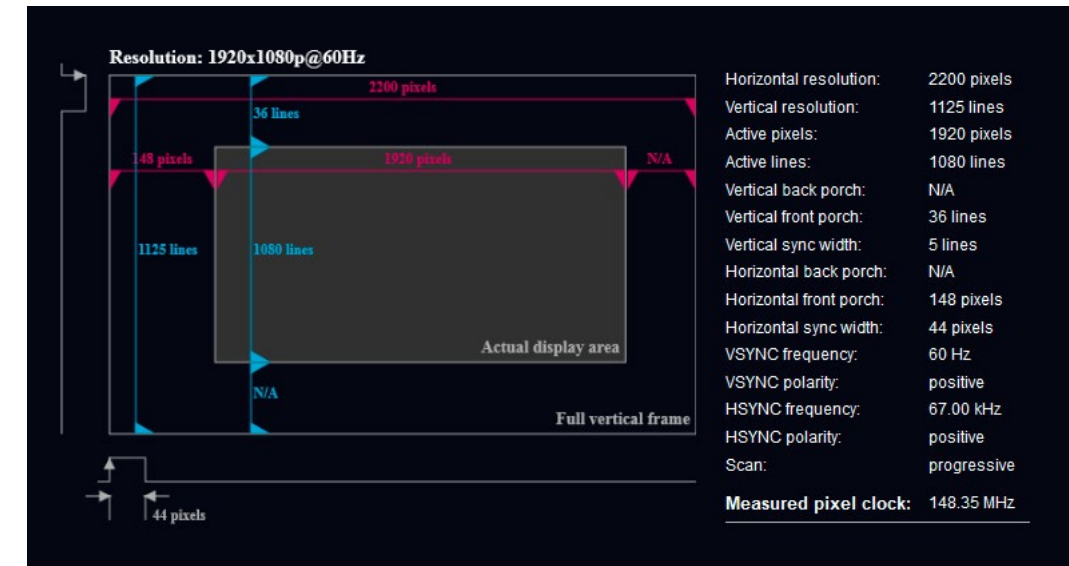

Frame Detector (Opened in a New Tab)

Frame Detector measures detailed timings on the video signals just like a built-in oscilloscope, but it is much more easy to use. Actual display area shows the active video size (light grey). Dark grey area of the full frame is the blanking interval, which can contain the info frames and embedded audio data for HDMI signals. Shown values are measured directly on the signal and not retrieved only from the HDMI info frames.

5.5.3. Audio Settings

Audio sink: you can select where to transmit the audio, towards the HDMI sink and/or the analog audio device connected to the Decoder.

The volume of the analog audio can be set by using the slider.

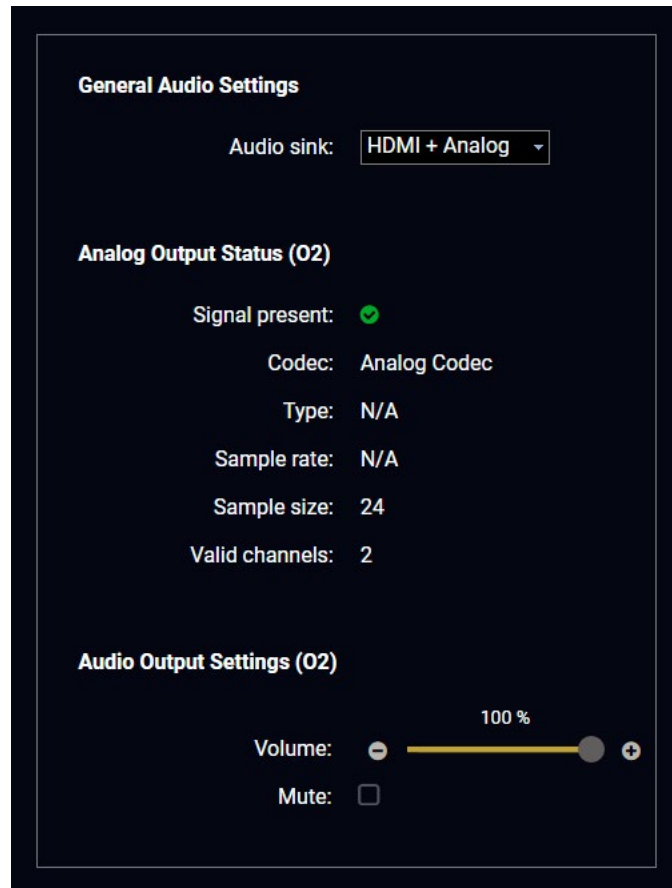

General Audio Settings in a Decoder

#audio #analogaudio #volume #mute #unmute

5.6. Crosspoint Menu

The page allows the user to make crosspoint switches between the encoders and the decoder end-points (individual decoders or video walls) in the system. From firmware package v3.0.1, all connected devices in the network (even if the number of endpoints exceeds 100) will appear on the Crosspoint page.

#crosspoint #switch

The TX means the **Encoder**, the RX means the **Decoder**, and the defined **Video Walls** are shown as **VW**.

ATTENTION! Please note that the Decoders that belong to a Video wall will not be displayed as individual devices.

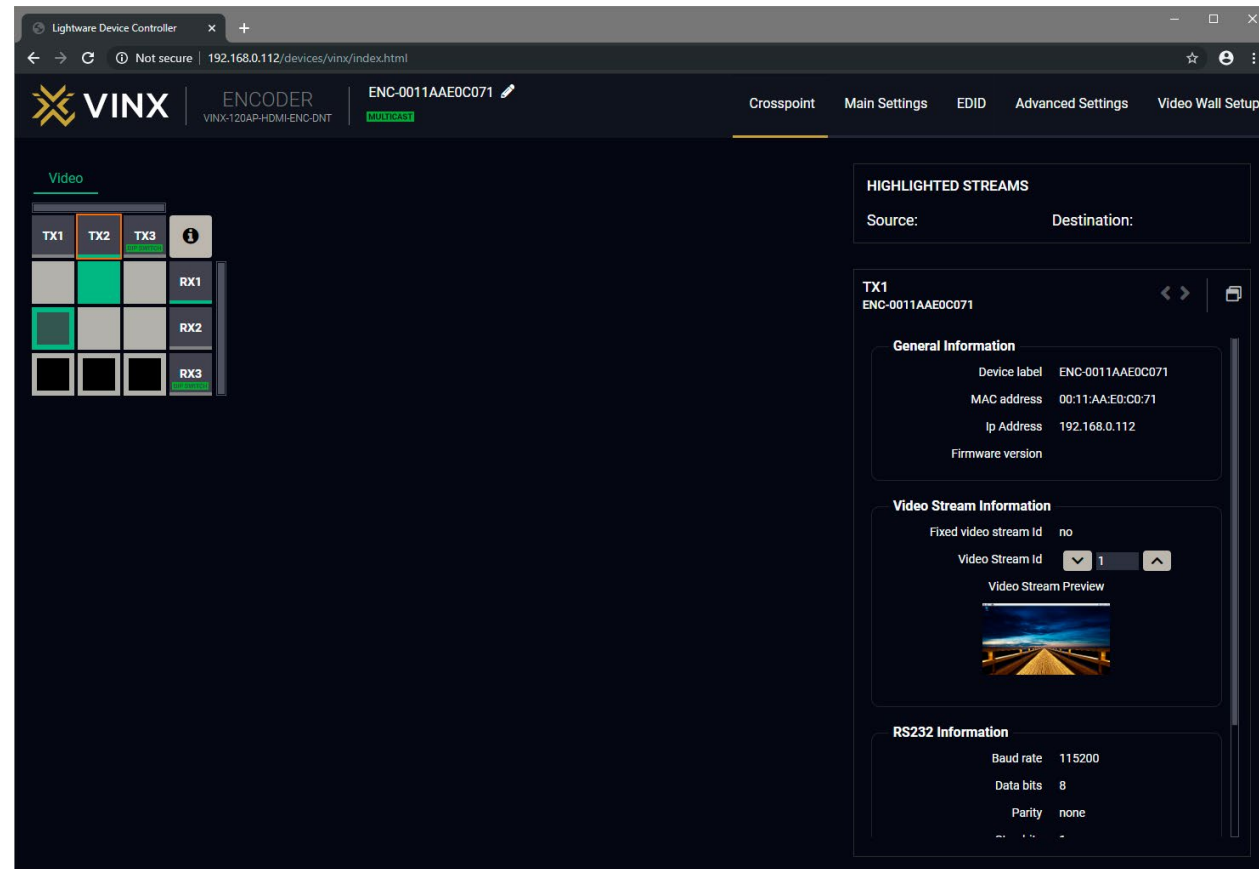

The Crosspoint Menu

The applied icons in the Crosspoint mean different states as follows:

- | | | | |
|---|--|---|--------------------------------------|
|  | Unselected connection |  | Selected but disabled connection |
|  | Selected connection with no signal present |  | Active stream, but no signal present |
|  | Selected connection with signal present |  | Stream ID is set by DIP switch |
|  | Unselected and disabled connection |  | Signal present |

Press the  button to open the **Legend** window and display the list above.

5.6.1. Grid view

The crosspoint settings can be viewed in two different ways, one of which is the grid view. This is the default screen when a device is opened through LDC or the built-in web. In this screen you can see a crosspoint grid with the Encoder devices in the top row and the Decoder devices in the far right column.

The order is based on the MAC address of the devices.

On the right side you can find the most important settings and information on the chosen device.

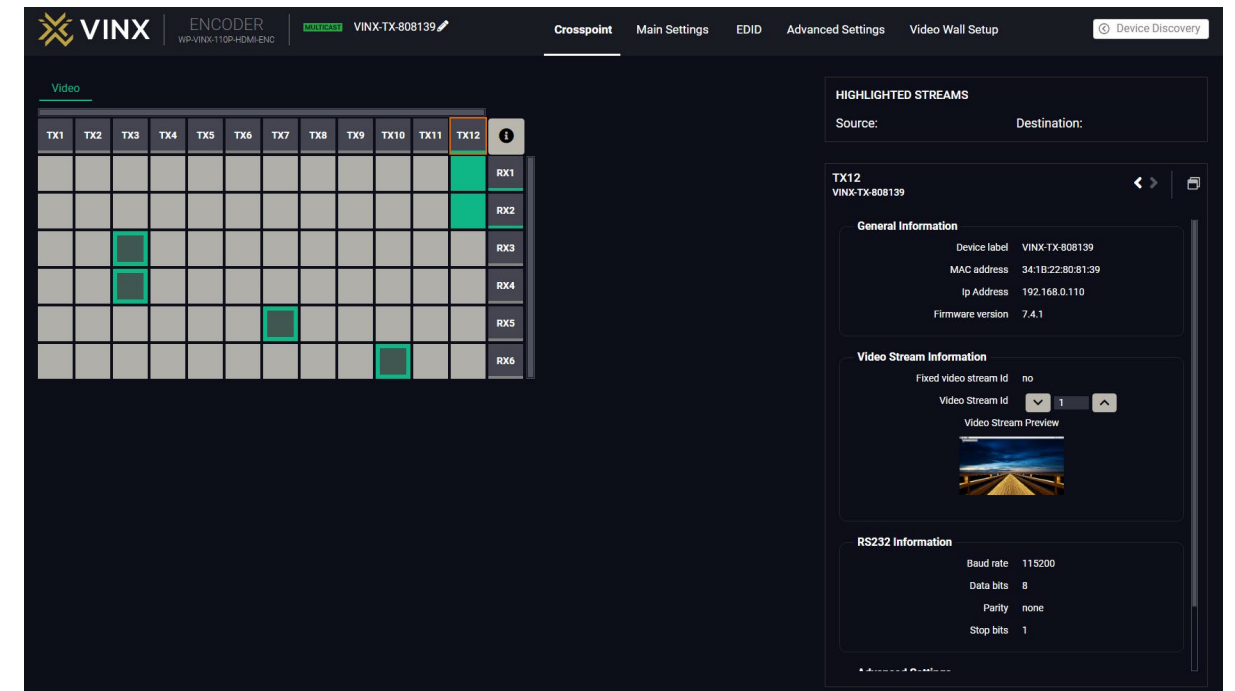

5.6.2. Tile view

The crosspoint menu also offers a view that shows the video signal as a preview on all Encoder and Decoder devices. This also serves to see which Decoders are connected to a certain Encoder, as the Decoders do not contain a preview, the screen shown is coming from the connected Encoder. The image of the decoders on this page does not change if a custom logo is set on the device, even if the connected display shows the custom logo. The image of the screens is updated every three seconds, in a way that does not pose a risk to people with photosensitive issues.

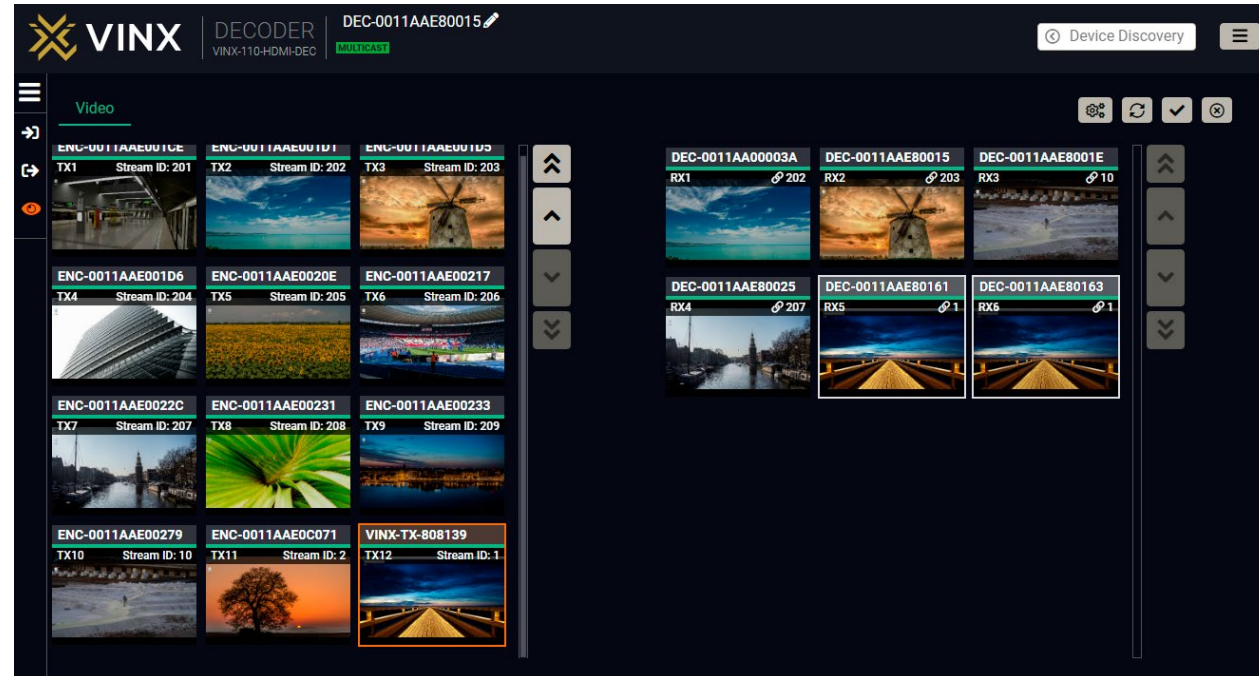

When you select an Encoder in this page, it will be highlighted in orange, and all connected Decoders will be highlighted in white. If you select a Decoder, it will be highlighted in orange, along with the connected Encoder.

On the left side you can find the Display modes. You can open the menu by clicking on the icon, or you can select the mode without opening it. This menu also contains the list of the selected and connected ports, visible only when the menu is open.

You can see several buttons in the top right corner: **Parameters**, **Autotake**, **Take** and **Cancel**.

Parameters button

When you select a device, the **Parameters** button becomes active. By clicking on it, you can access the most important information of the chosen device.

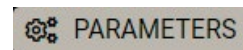

Cancel button

By pressing the **Cancel** button, you can deselect all of the devices that have been selected.

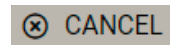

Take and Autotake buttons are explained in the following section.

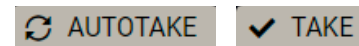

5.6.2.1. Display Modes

View Mode

The mode allows to display the current crosspoint-state. The crosspoint cannot be changed in this mode, but port settings are available. This mode is active on default.

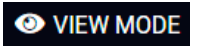

Input Switch Mode

The mode can also be named as 'Input priority-mode': an input port has to be selected first, then the connected output port(s) is/are shown. Thus, the output port(s) connected to the input port can be changed.



Output Switch Mode

This mode can also be named as 'Output priority-mode': an output port has to be selected first, then connected input port is shown. Thus, the output port connected to the input port can be changed. Output ports can be (un)locked or (un)muted only in Output switch mode.

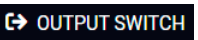

5.6.2.2. Crosspoint Operations

Switching in Take Mode #autotakemode

The grey **Autotake** button means Take mode is active. Any crosspoint change – (dis)connecting ports to/from the previously selected port – is executed only after pressing the **Take** button. The following steps describe the process of the switching:

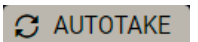

- Step 1.** Press the desired **Input switch** or **Output switch** button to select switching mode.
- Step 2.** Select the desired **port**; it will be highlighted in orange and displayed on the port bar on the left, too.
- Step 3.** Connected port(s) is/are highlighted in white and displayed on the port bar on the left, too.
- Step 4.** Create the desired **crosspoint settings** by (de)selecting the ports; they will start to blink.
- Step 5.** Press **Take** button to execute changes or **Cancel** to ignore the operations.

INFO: Take mode remains active until it is switched off. Selecting another view mode or menu does not change the Take/Autotake mode state.

Switching in Autotake Mode

The yellow colored **Autotake** button means Autotake mode is active. Any crosspoint change – (dis)connecting ports to/from the previously selected port – is executed immediately after pressing the port button. Following steps describe the process of the switching:

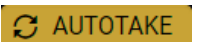

- Step 1.** Press the desired **Input switch** or **Output switch** button to select switching mode.
- Step 2.** Select the desired **port**; it will be highlighted in orange and displayed on the port bar on the left, too.
- Step 3.** Connected ports are highlighted in white and displayed on the port bar on the left, too.
- Step 4.** Create the desired crosspoint settings by **(de)selecting the ports**; the changes are executed immediately.

INFO: Autotake mode remains active until it is switched off. Selecting another view mode or menu does not change the Take/Autotake mode state.

5.7. EDID Menu

DEFINITION: The **Extended Display Identification Data (EDID)** is the passport of the display devices. It contains information about the capabilities of the display, such as supported resolutions and audio formats, refresh rates, the type and the manufacturer of the display device, etc.

Advanced EDID Management is available in the Encoder. Navigate to the **EDID** menu. There are two panels: the left contains the **Source EDIDs**, the right panel contains the **Destination places** where the EDIDs can be emulated or copied. See more information in the [EDID Management](#) section. #edid

Memo...	Manuf...	Resolution	Audio	Monitor Name
F1	LWR	640x480p60.00Hz	N/A	D640x480p60
F3	LWR	800x600p60.32Hz	N/A	D800x600p60
F4	LWR	1024x768p60.00Hz	N/A	D1024x768p60
F5	LWR	1280x768p50.00Hz	N/A	D1280x768p50
F6	LWR	1280x768p59.94Hz	N/A	D1280x768p60
F7	LWR	1280x768p75.00Hz	N/A	D1280x768p75
F8	LWR	1360x768p60.02Hz	N/A	D1360x768p60
F9	LWR	1280x1024p50.00Hz	N/A	D1280x1024p50
F10	LWR	1280x1024p60.02Hz	N/A	D1280x1024p60
F11	LWR	1280x1024p75.02Hz	N/A	D1280x1024p75
F15	LWR	1680x1050p60.00Hz	N/A	D1680x1050p60
F16	LWR	1920x1080p50.00Hz	N/A	D1920x1080p50
F17	LWR	1920x1080p60.00Hz	N/A	D1920x1080p60
F20	LWR	1600x1200p50.00Hz	N/A	D1600x1200p50
F21	LWR	1600x1200p60.00Hz	N/A	D1600x1200p60
F22	LWR	1920x1200p50.00Hz	N/A	D1920x1200p50
F23	LWR	1920x1200p59.56Hz	N/A	D1920x1200p60
F29	LWR	1920x1080p60.00Hz	N/A	Univ_DVI

Memory	Manuf...	Resolution	Audio	Monitor Name
U1	N/A	N/A	N/A	N/A
U2	N/A	N/A	N/A	N/A
U3	N/A	N/A	N/A	N/A
U4	N/A	N/A	N/A	N/A
U5	N/A	N/A	N/A	N/A

The EDID Menu (in an Encoder)

5.7.1. The EDID Memory Structure

The EDID memory consists of four parts:

- **Factory EDID list** shows the pre-programmed EDIDs (F1-F132).
- **Decoder EDID list** shows the EDIDs of the display devices connected to the assigned Decoders. The Decoders store the last display devices' EDID on the HDMI output, so there is an EDID shown even if there is no display device attached to the output port at that moment.
- **User memory locations** (U1 – U5) can be used to save custom EDIDs. Any EDID from any of the User/Factory/Decoder EDID lists can be copied to the user memory.
- **Emulated EDID** shows the currently emulated EDID for the HDMI input port of the Encoder. The source column displays the memory location that the current EDID was routed from.

5.7.2. EDID Operations

Changing the Emulated EDID

- Step 1.** Choose the desired **EDID list** on the source panel and select an **EDID**.
- Step 2.** Select the **Emulated** tab on the Destination panel.
- Step 3.** Select the desired **port** on the right panel.
- Step 4.** Press the **Transfer** button to change the emulated EDID.

Learning an EDID

The process is the same as when changing the emulated EDID; the only difference is the Destination panel: select the **User** tab. This way, one or more EDIDs can be copied into the user memory.

Exporting an EDID

The source EDID can be downloaded as a file (*.EDID) to the computer.

- Step 1.** Select the desired **EDID** from the Source panel.
- Step 2.** Press the **Export** button and save the file to the computer.

Importing an EDID

Previously saved EDID file (*.EDID) can be uploaded to the user memory:

- Step 1.** Select the **User** tab on the Source panel and select a **memory slot**.
- Step 2.** Press the **Import** button below the Source panel.
- Step 3.** Browse the file in the opening window, then press the **Open** button. The content of the EDID file is imported into the selected User memory.

ATTENTION! The new EDID overwrites the selected memory place.

Deleting EDID(s)

The EDID(s) from the User memory can be deleted as follows:

- Step 1.** Select the **User** tab on the Destination panel.
- Step 2.** Select the desired **memory slot(s)**; one or more can be selected (**Select All** and **Select None** buttons can be used).
- Step 3.** Press the **Clear selected** button to delete the EDID(s).

5.8. Advanced Settings

5.8.1. Common Settings (Encoder and Decoder)

The submenu contains two tabs: **Multicast** and **Unicast**. The currently valid mode is highlighted with yellow. Press the desired button to choose the mode and access the settings. [#unicast](#) [#multicast](#)

ATTENTION! When the mode is changed, the device must be restarted; you will get a notification.

Network Settings [#network](#) [#ipaddress](#) [#dhcp](#)

The factory default IP address of the extender is set by the DHCP server. The drop-down list and the further parameters allow changing the network settings to the desired value.

ATTENTION! When the desired Network parameters are set, press the **Apply changes** button; the device will reboot.

Please use the port number 6107 for connecting to the device directly from a third-party application.

Update Firmware [#firmwareversion](#)

For the details, please see the [Firmware Updatedate](#) section.

Programmers' LW3 Terminal

See the [LW3 Terminal](#) section.

RS-232 Settings [#rs232](#) [#rs-232](#) [#serial](#)

The RS-232 serial data transmission is fully transparent between the Encoder and the connected Decoder devices. All data received on the serial port of the Decoders is transmitted to the serial port of the Encoder and vice versa: the data received on the serial port of the Encoder is transmitted to the serial port of all connected Decoders.

ATTENTION! The data transmission works only if the serial port parameters were set to the same values in all the devices: serial data sender/receiver and the VINX Encoder and Decoder devices.

See more information in the [RS-232 Interface](#) section.

USB Settings (Multicast Mode)

The **Encoder** displays the name of the currently connected Decoder.

The **Decoder** displays whether the USB connection is established; press the button to acquire the connection if needed. [#usbkvm](#) [#kvm](#)

Restart and Factory Default Settings [#reboot](#) [#reset](#) [#restart](#)

Scroll down to these dedicated buttons. [#factory](#)

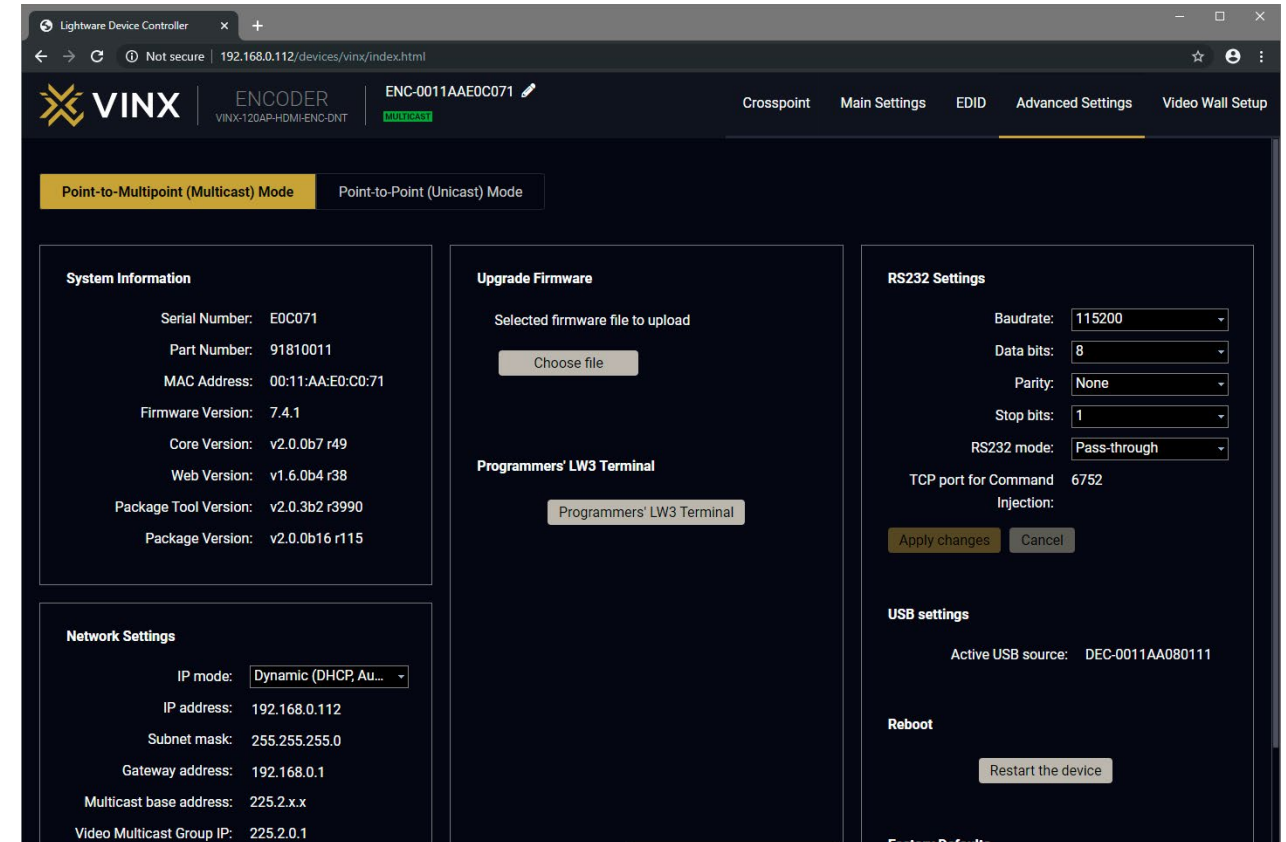

The Advanced Settings Menu of an Encoder in Multicast Mode

5.8.2. Decoder-related Settings

OSD Settings (the On-Screen Display Feature) *#osd*

Certain system messages can be displayed on the connected screen; the following are defined:

- **Enable OSD:** set it to 'ON' state to enable the OSD feature.
- **HDCP messages:** 'HDCP failed'
- **USB messages:** 'Requesting USB', 'Starting USB', 'Stopping USB'
- **Video quality messages:** 'Graphics mode', 'Movie mode'
- **Dither messages:** reserved
- **Other messages:** reserved

Press the **Apply changes** button and **restart** to save the new settings.

Keyboard Shortcuts

A keyboard connected to the USB 1.1 port of a Decoder can be used to change the assigned Encoder to another one. Thus, the input source of a Decoder can be changed quickly and easily.

INFO: The Video Stream ID of the Decoder is changed when a command is executed.

The shortcut can be set:

- to select a certain stream directly, or
- to select the next/previous stream in the list.

Setting (Changing) a Shortcut

Step 1. Open the web page of the desired Decoder and navigate to the **Advanced Settings** page.

Step 2. Connect an USB keyboard to that computer directly, or through the desired Decoder and the Encoder (make sure the Encoder is connected to the computer via USB).

Step 3. Place the cursor in the desired Shortcut box.

Step 4. Press the desired key combination; the new setting will be displayed and stored.

Executing a Command (Calling a Shortcut)

Connect the keyboard to an **USB 1.1 port** (not the USB 2.0!) of the desired Decoder. Press the key(s) **three times** quickly (within 750 ms). Please note that in the case of a combination (e.g. Alt + A), it is enough to hold the first key while pressing the second key three times in quick succession.

Stream ID List *#videostreamid #streamid*

You can set a custom list of streams, this way, the Previous/Next stream shortcuts will select the streams in the desired order.

Scaler Settings *#scaler*

The same options as in the [Scaler settings](#) section.

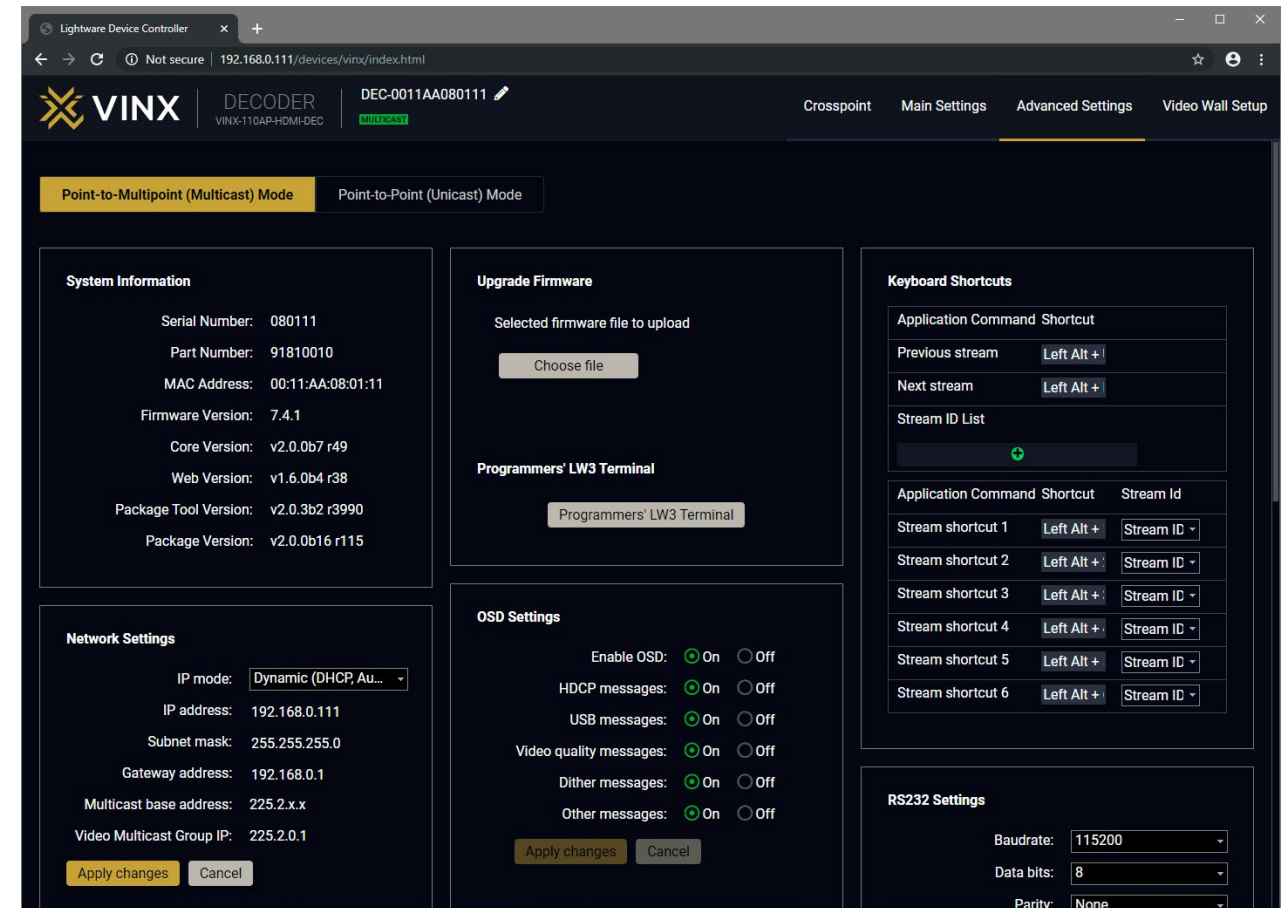

The Advanced Settings Menu of a Decoder in Multicast Mode

5.8.3. LW3 Terminal

This window is the surface of the Lightware Protocol 3 (LW3) tree with a terminal window. Commands and specific parameters (which are not available on the graphical user interface of the LDC) can be run and set. The introduction of the LW3 protocol and the most important commands can be found in the [Programmer's Reference](#) section.

Legend *#terminal*

- 1 **LW3 Protocol Help** Displaying the most important information about LW3 protocol commands in a new window.
- 2 **Terminal Window** Commands and responses with time and date stamps are listed in this window. Sent command starts with '>' character, received response starts with '<' character. The content of the window can be emptied by the **Clear** button. If the **Autoscroll** option is ticked, the list is scrolled automatically when a new line is added.
- 3 **Edit Mode** The default appearance is the read-only mode. If you want to modify the values or parameters, tick the option. You will be prompted to confirm your selection.
- 4 **Protocol Tree** LW3 protocol tree; select an item to see its content.
- 5 **Node List** The parameters and nodes of the selected item in the protocol tree are shown.
 - **Manual** button: displaying the manual (short description) of the node in a pop-up window.
 - **Set** button: Saving the value/parameter typed in the textbox.
 - **Call** button: Executing the method, e.g. reloading the factory default settings.
- 6 **Warning Mode** If this option is enabled, a warning window pops up when you enable the **Edit mode**.
- 7 **Command Line** Type the desired command and execute it by pressing the **Send** button.

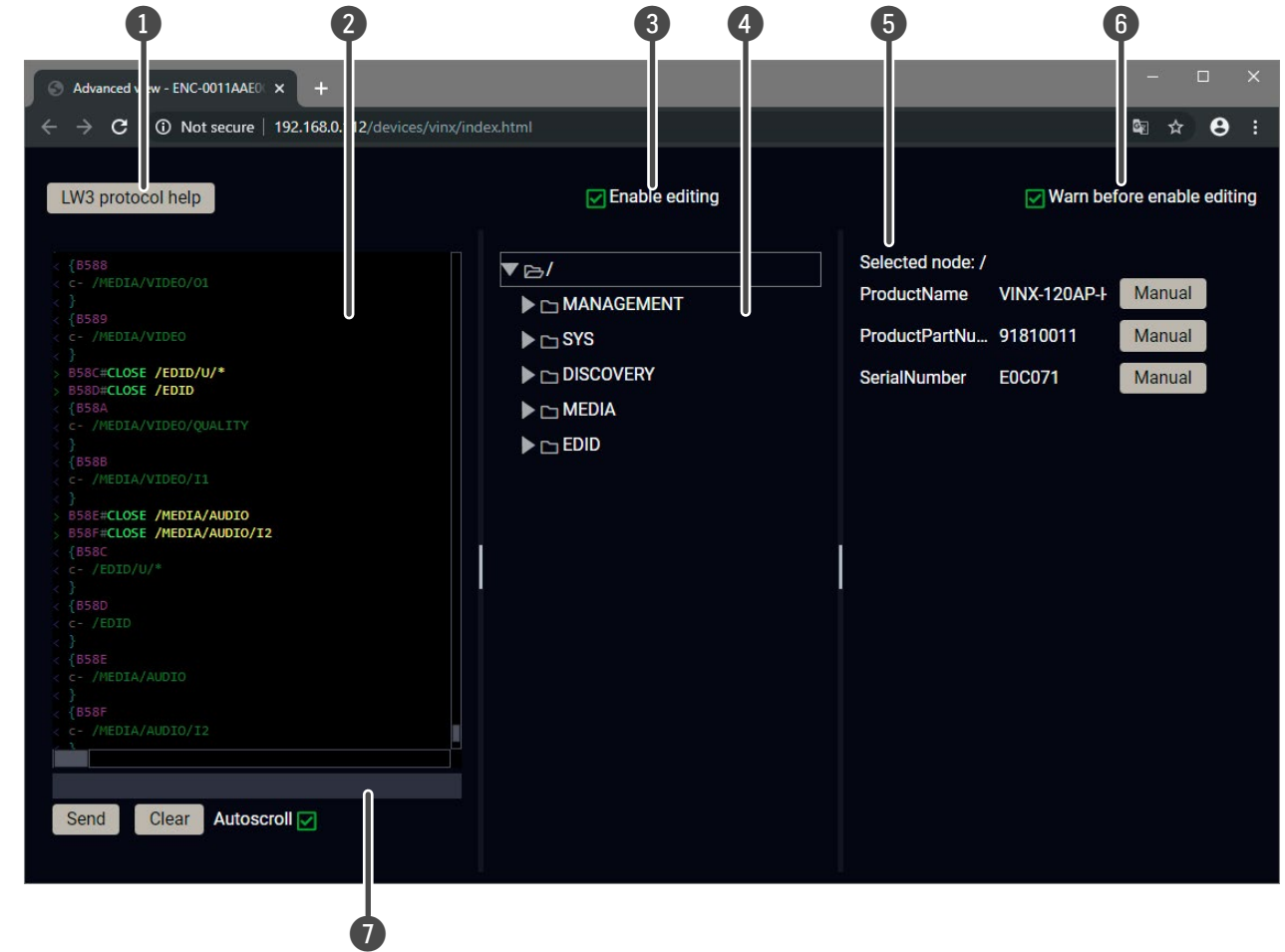

The Terminal Window

5.9. Video Wall Setup

ATTENTION! This tab is displayed only when the device is in Multicast mode. Although changing parameters usually takes effect within an acceptable period of time, it might happen that feedback is not received and not visible on the web page for several seconds.

Basic Rules *#videowall*

- One Decoder can be a part of only one video wall.
- The video wall must have a unique name within a system; the length of the name shall not exceed 24 characters.
- The video wall parameters are stored in the LW3 protocol tree of the Decoders but you can also create/access it in the Encoder.

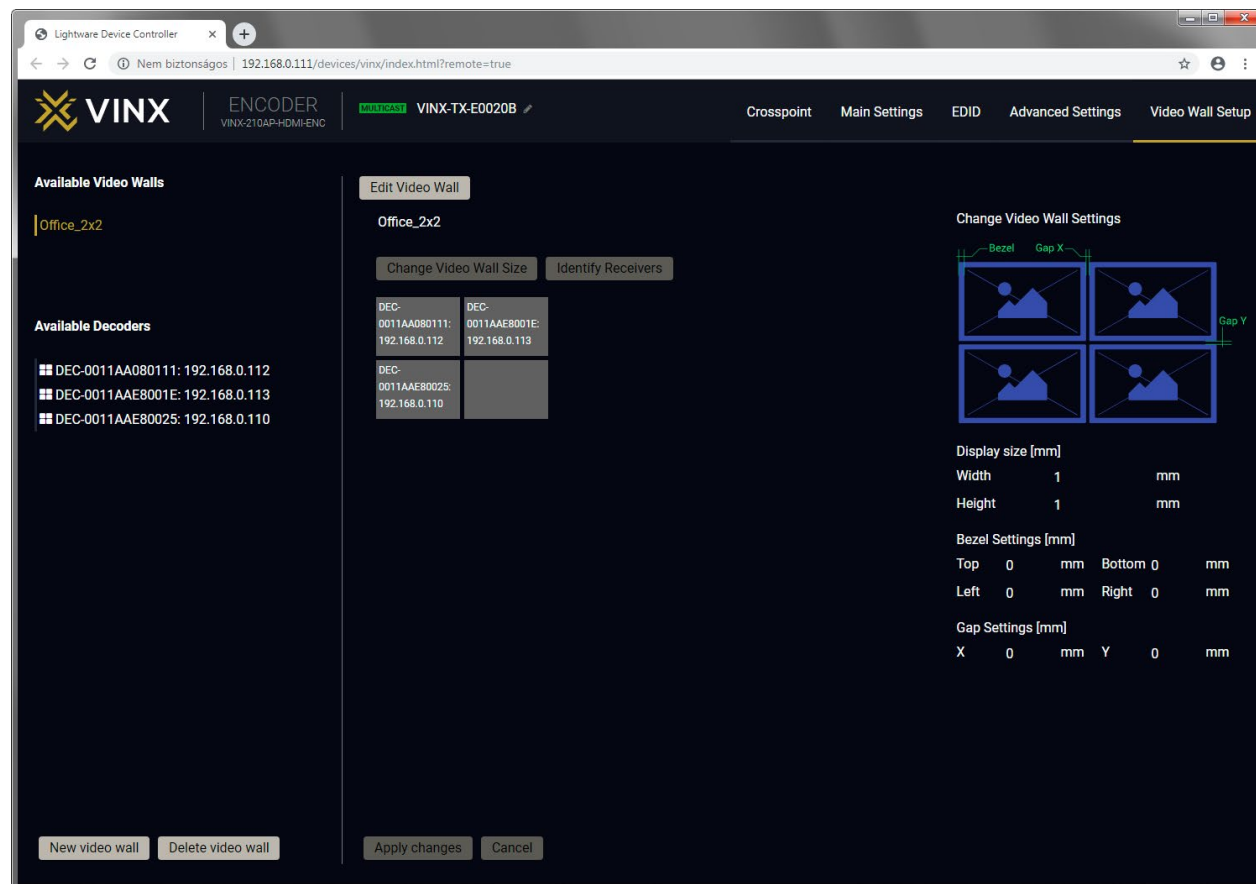

The Video Wall Setup Page

5.9.1. Creating a Video Wall

- Step 1.** Navigate to the **Video Wall Setup** page.
- Step 2.** Press the **New video wall** button. Enter the desired name of the wall (press the pencil icon  to change) and press the **Enter** or click on the pencil icon.
- Step 3.** Press the **Change Video Wall Size** button to set the exact size of the wall. A new window will pop up, click on the desired size (see besides).
- Step 4.** Drag and drop the Decoders to the desired place in the wall.
- Step 5.** Press the **Apply changes** button to save the settings.

ATTENTION! A New video wall is stored only when at least one Decoder is linked to the wall.

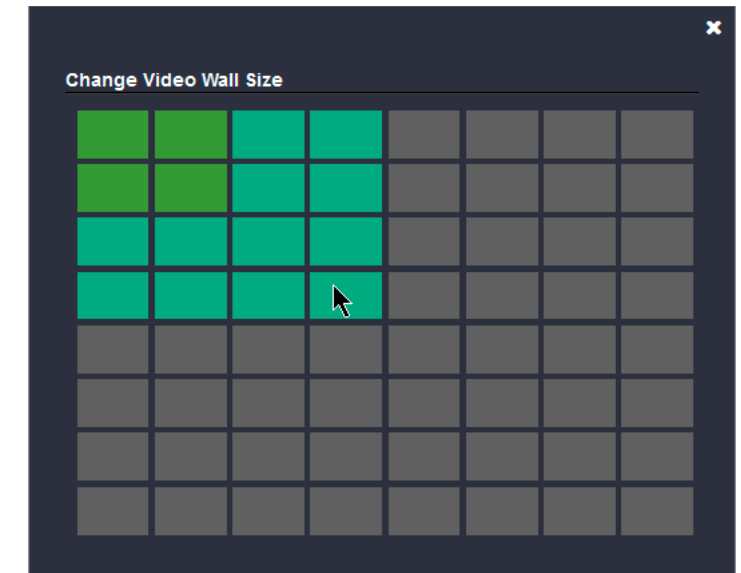

5.9.2. Identify the Decoders

The Decoders of a video wall can be identified by pressing the **Identify Receivers** button. In this case, the IP address and the position in the Video wall is displayed on the connected screens.

Identify Receivers

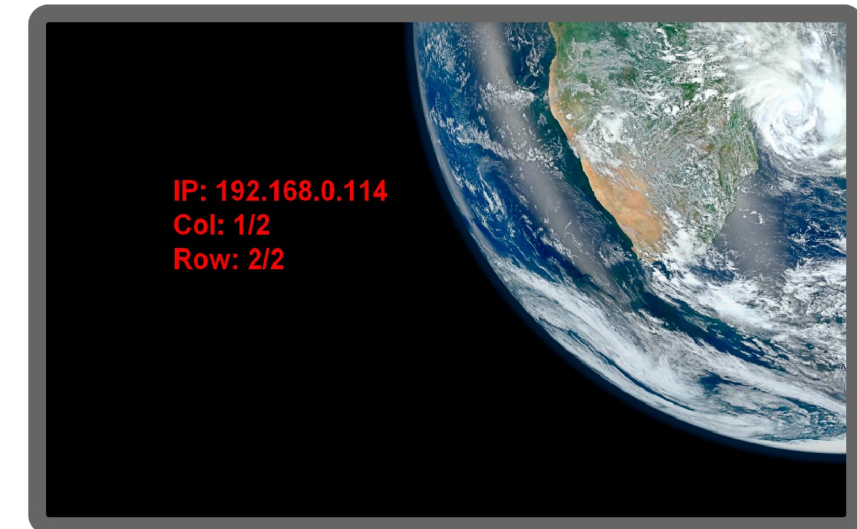

5.9.3. Gap and Bezel Settings

ATTENTION! Always press the **Apply changes** button if you want to save the changes of the parameters mentioned below.

DEFINITION: Hereby defined **Gap** means the physical distance between the edges of the display devices – see the attached figure.

DEFINITION: The **Bezel** means the thickness of the Display device's frame – see the attached figure.

In certain cases, the dimensions of the sinks and the arrangement of the video wall requires special parameters to be set. The Gap and Bezel parameters allow the setting of the non-visible areas (between the display devices) of the image:

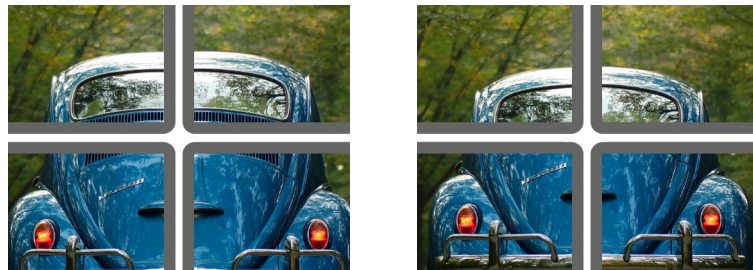

No Gap (left) and Manually Set Gap (right)

- **No Gap:** The left figure shows that no gap is defined. In this case, the whole image is shown on the screens but the image looks a bit distorted.
- **Defined Gap:** The right figure shows that gap is defined, therefore some part of the image is not visible, but the appearance of the overall image is more realistic.

Set the bezel and gap parameters that best suit the current image content.

The following parameters can be set:

- **Display Size** (width and height): the physical size (dimensions) of the screen (screen size + bezel).
- **Bezel Settings** (top, bottom, left, right): the physical size (thickness) of the bezel.
- **Gap Settings** (horizontal, vertical): the distance of the displays (see the following section).

INFO: If the Bezel and Gap values are set to zero, the Display size values (dimensions) do not matter.

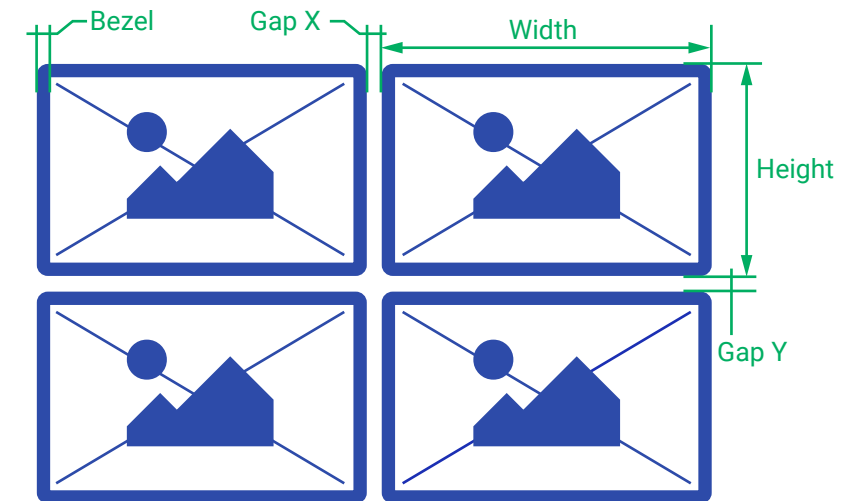

5.9.4. Modifying a Video Wall

The Name of the Video Wall

Step 1. Press the **Edit Video Wall** button.

Step 2. Change the name of the video wall and press the **Apply changes** button.

Changing the Layout of the Decoders

Step 1. Press the **Edit Video Wall** button.

Step 1. Drag and drop a Decoder to the below indicated red colored (hidden) place; the device will be removed from the wall.

Step 2. Another Decoder can be dragged and dropped to the empty place.

Step 3. Press the **Apply changes** button to save the settings.

ATTENTION! If you reduce the size of an existing video wall, the Decoders that would be outside of the new area show the original picture.

Changing the Gap and Bezel Settings

Step 1. Press the **Edit Video Wall** button.

Step 2. Set the desired gap and bezel values and press the **Apply changes** button to save the settings.

5.9.5. Deleting a Video Wall

Step 1. Select the video wall from the list.

Step 2. Click on the **Delete video wall** button and confirm in the pop-up window. The original image will be displayed on all connected Decoders.

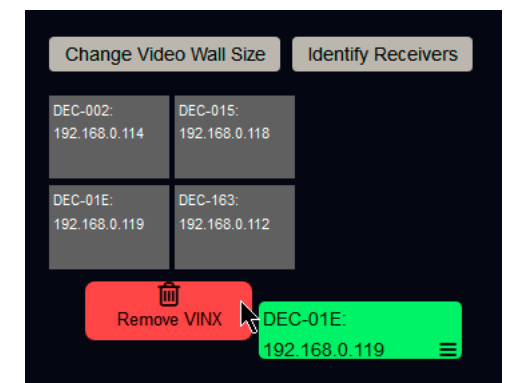

6

Programmer's Reference

The device can be controlled through Lightware 3 (LW3) protocol commands to ensure the compatibility with other Lightware products. The supported LW3 commands are described in this chapter.

- ▶ [OVERVIEW](#)
- ▶ [INSTRUCTIONS FOR THE TERMINAL APPLICATION USAGE](#)
- ▶ [PROTOCOL RULES](#)
- ▶ [SYSTEM COMMANDS](#)
- ▶ [CLEARTEXT LOGIN PROTECTION](#)
- ▶ [NETWORK CONFIGURATION](#)
- ▶ [ENCODER-RELATED COMMANDS](#)
- ▶ [DECODER-RELATED COMMANDS](#)
- ▶ [CUSTOM LOGO MANAGEMENT](#)
- ▶ [AUDIO-RELATED COMMANDS](#)
- ▶ [ANALOG AUDIO INPUT/OUTPUT SIGNAL LEVEL SETTINGS](#)
- ▶ [SERIAL PORT SETTINGS](#)
- ▶ [ARRANGING THE EXTENDERS TO GROUPS](#)
- ▶ [VIDEO WALL SETTINGS](#)
- ▶ [SETTING UP A VIDEO WALL \(EXAMPLE\)](#)
- ▶ [CROSSPOINT SWITCHING EXAMPLES](#)
- ▶ [EDID MANAGEMENT \(ENCODER\)](#)
- ▶ [LW3 COMMANDS - QUICK SUMMARY](#)

6.1. Overview

The Lightware Protocol #3 (LW3) is implemented in almost all new Lightware devices (matrix switchers, signal extenders and distribution amplifiers) since 2012. The protocol is ASCII-based and all commands are terminated with a carriage return (Cr, '\r') and line feed (Lf, '\n') pair. It is organized as a tree structure that provides outstanding flexibility and user-friendly handling with 'nodes', 'properties' and 'methods'. The **Advanced View** of the Lightware Device Controller software is the perfect tool for browsing and learning how the LW3 protocol can be used in practice.

6.2. Instructions for the Terminal Application Usage

Terminal Application

The LW3 protocol commands can be applied to the receiver using a terminal application. You need to install one of them to your control device, for example **Putty** or **CLI**. `#terminal`

Establishing Connection

Follow the steps for establishing connection to the receiver:

- Step 1.** Connect the receiver to a LAN over Ethernet.
- Step 2.** Open the terminal application (e.g. Putty).
- Step 3.** Add the **IP address** of the device (default: 192.168.0.100) and the **port number (6107)**.
- Step 4.** Select the **Raw** connection type, and open the connection.

Once the terminal window is opened, you can enter the LW3 protocol commands that are listed in the following sections.

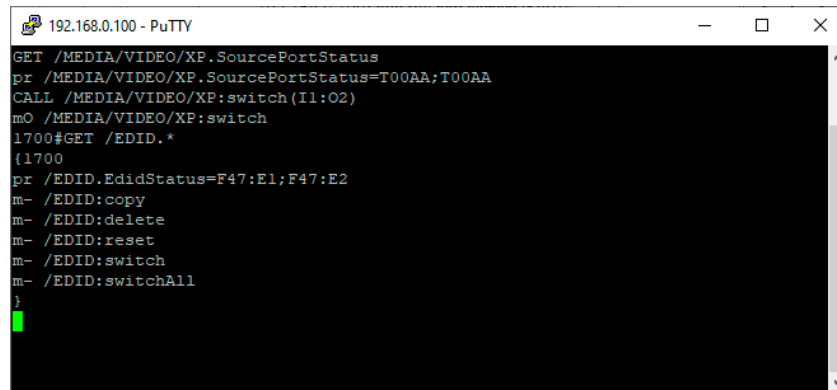
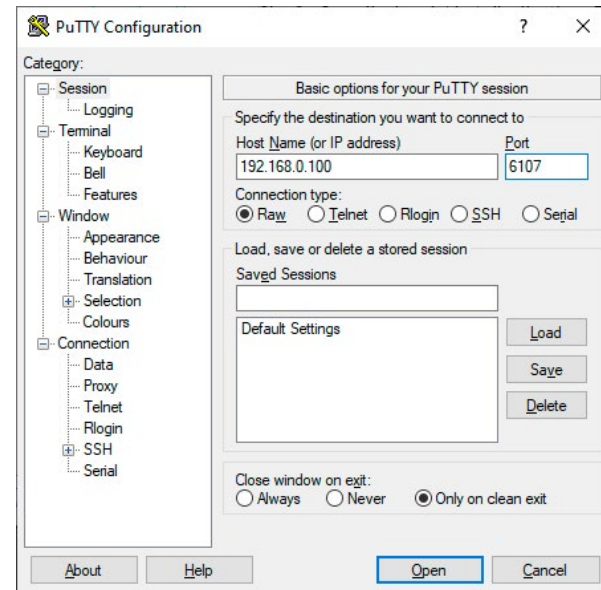

LW3 protocol command communication in a terminal window

6.3. Protocol Rules

6.3.1. The LW3 Tree and Command Structures

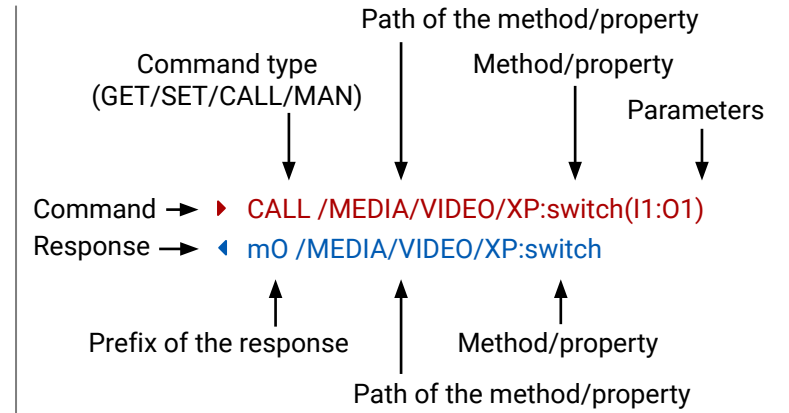
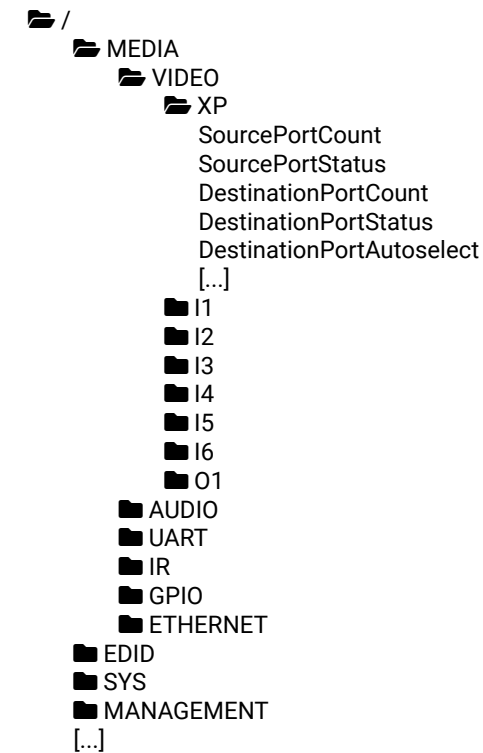

6.3.2. Legend for the Control Commands

Command and Response – Example

- ▶ GET-/SYS/MB/GPIO.DipSwitch
- ◀ pr-/SYS/MB/GPIO.DipSwitch=<DIP_value>

Format	Description
<in>	Input port number
<out>	Output port number
<port>	Input or output port number
<loc>	Location number
▶	Sent command
◀	Received response
·	Space character

Further not listed <parameters> are defined at each commands.

6.3.3. General Rules

- All names and parameters are **case-sensitive**.
- The nodes are separated by a slash ("/) character.
- The command lines have to be closed by Carriage return and Line Feed (CrLf)
- The node name can contain the elements of the English alphabet and numbers.
- The length of a line (command/response, command type / prefix, path, method/property and parameters together) can be **max. 800 bytes**.
- Use the **TCP port no. 6107** when using LW3 protocol over Ethernet.
- When a command is issued by the device, the received response cannot be processed by the CPU.
- The path of a node has to contain all parent nodes from the root node.

6.3.4. Command Types

GET command

The **GET** command can be used to get the child nodes, properties and methods of a specific node. It can also be used to get the value of a property. Use the dot character (.) when addressing a property:

- ▶ **GET /.SerialNumber**
- ◀ **pr /.SerialNumber=87654321**

GETALL command

The **GETALL** command can be used to get all child nodes, properties and methods of a node with one command.

- ▶ **GETALL /MEDIA/UART**
- ◀ **n- /MEDIA/VIDEO/I1**
- ◀ **n- /MEDIA/VIDEO/O1**
- ◀ **n- /MEDIA/VIDEO/QUALITY**
- ◀ **pr /MEDIA/VIDEO.I1=I1**
- ◀ **pr /MEDIA/VIDEO.O1=O1**
- ◀ **pr /MEDIA/VIDEO.PortCount=2**

SET command

The **SET** command can be used to modify the value of a property. Use the dot character (.) when addressing the property:

- ▶ **SET /MEDIA/VIDEO/QUALITY.QualityMode=0**
- ◀ **pw /MEDIA/VIDEO/QUALITY.QualityMode=0**

CALL command

A method can be invoked by the **CALL** command. Use the colon character (:) when addressing the method:

- ▶ **CALL /MEDIA/VIDEO/QUALITY:applySettings(true)**
- ◀ **m0 /MEDIA/VIDEO/QUALITY:applySettings**

6.3.5. Prefix Summary

DEFINITION: The prefix is a 2-character long code that describes the type of the response.

The following prefixes are defined in the LW3 protocol:

Prefix	Description
n-	a node
nE	an error for a node
nm	a manual of a node
ns	a child node of a node
pr	a read-only property
pw	read-write property
pE	an error for the property
pm	a manual for the property
m-	a method
mO	a response after a success method execution
mF	a response after a failed method execution
mE	an error for a method
mm	a manual for a method

6.3.6. Error Messages

There are several error messages defined in the LW3 protocol, all of them have a unique error number.

- ▶ SET /MEDIA/UART/P1.Baudrate=9
- ◀ pE /MEDIA/UART/P1.Baudrate %E004:Invalid value

6.3.7. Escaping

DEFINITION: An escape sequence is a sequence of characters that does not represent itself when used inside a character or string literal, but is translated into another character or a sequence of characters.

Property values and method parameters can contain characters that are used as control characters in the protocol. They must be escaped. The escape character is the backslash (\) and escaping means injecting a backslash before the character that should be escaped (like in C language).

Control characters are the following: \ { } # % () \r \n \t

The **original** message:

```
CALL /MEDIA/UART/P1:sendMessage(Set(01))
```

The **escaped** message:

```
CALL /MEDIA/UART/P1:sendMessage(Set\\(01\\))
```

6.3.8. Signature

DEFINITION: The signature is a four-digit-long hexadecimal value that can be optionally placed before every command to keep a command and the corresponding responses together as a group.

Each line is terminated with a carriage return (Cr, '\r') and line feed (Lf, '\n') characters. In several cases, the number of the lines in the response cannot be determined in advance, e.g. the client is intended waiting for the whole response and also wants to be sure that the received lines belong together and to the same command. In these cases, a special feature, the 'signature' can be used. In these cases, the response to that particular command will also be preceded by the signature, and the corresponding lines will be between brackets:

```
▶ 1700#GET /EDID.*
◀ {1700
◀ pr /EDID.EdidStatus=F89:E1;D1:E2;D1:E3;D1:E4;F89:E5
◀ m- /EDID:copy
◀ m- /EDID:delete
◀ m- /EDID:reset
◀ m- /EDID:switch
◀ m- /EDID:switchAll
◀ }
```

INFO: The lines of the signature are also Cr and Lf terminated.

6.3.9. Subscription

DEFINITION: Subscribing to a node means that the user will get a notification if any of the properties of the node is changed.

A user can subscribe to any node. These notifications are asynchronous messages and they are useful to keep the client application up to date, without receiving any unwanted information. When the user does not want to be informed about the changes anymore, he can simply unsubscribe from the node.

ATTENTION! The subscriptions are handled separately for connections. Hence, if the connection is terminated, all registered subscriptions are deleted. After closing a connection, the subscribe command has to be sent in order to get the notifications of the changes on that connection.

Subscribe to a Node

- ▶ OPEN /MEDIA/VIDEO
- ◀ o- /MEDIA/VIDEO

Get the Active Subscriptions

- ▶ OPEN
- ◀ o- /MEDIA/VIDEO
- ◀ o- /EDID
- ◀ o- /DISCOVERY

Subscribe to Multiple Nodes

- ▶ OPEN /MEDIA/VIDEO/*
- ◀ o- /MEDIA/VIDEO/*

Unsubscribe from a Node

- ▶ CLOSE /MEDIA/VIDEO
- ◀ c- /MEDIA/VIDEO

Unsubscribe from Multiple Nodes

- ▶ CLOSE /MEDIA/VIDEO/*
- ◀ c- /MEDIA/VIDEO/*

6.3.10. Notifications about the Changes of the Properties

When the value of a property is changed and the user is subscribed to the node which the property belongs to, an asynchronous notification is generated. This notification is called the 'change message'. The format of such a message is very similar to the response for the GET command:

◀ CHG /EDID.EdidStatus=F48:E1

A Short Example of How to Use the Subscription

There are two independent users controlling the device through two independent connections (**Connection #1** and **Connection #2**). The events in the rows occur after each other.

<ul style="list-style-type: none"> ▶ OPEN /MEDIA/VIDEO/QUALITY ◀ o- /MEDIA/VIDEO/QUALITY ▶ GET /MEDIA/VIDEO/Quality.QualityMode ◀ pm /MEDIA/VIDEO/Quality.QualityMode=graphic 	connection #1
<ul style="list-style-type: none"> ▶ GET /MEDIA/VIDEO/Quality.QualityMode ◀ pm /MEDIA/VIDEO/QUALITY.QualityMode=graphic ◀ SET /MEDIA/VIDEO/Quality.QualityMode=movie ◀ pw /MEDIA/VIDEO/QUALITY.QualityMode=movie 	connection #2
<ul style="list-style-type: none"> ◀ CHG /MEDIA/VIDEO/QUALITY.QualityMode=movie 	connection #1

Explanation: The first user (**Connection #1**) set a subscription to a node. Later the other user (**Connection #2**) made a change, and thanks to the subscription, the first user got a notification about the change.

6.4. System Commands

6.4.1. Querying the Product Name

Command and Response

- ▶ GET /.ProductName
- ◀ pr /.ProductName=<Product_name>

Parameters

The <Product_name> is the type of the device: it is a read-only parameter and cannot be modified.

Example

- ▶ GET /.ProductName
- ◀ pr /.ProductName=VINX-120-HDMI-ENC

6.4.2. Setting the Device Label

A unique name can be set that will be visible when the given device is listed in the built-in web page of other VINX devices. Furthermore, the name is listed when browsing the client list of a DHCP server.

ATTENTION! This property is a writable parameter and not the same as the **ProductName**.

Command and Response #label #devicelabel

- ▶ SET /SYS/MB.DeviceLabel=<Custom_name>
- ◀ pw /SYS/MB.DeviceLabel=<Custom_name>

Parameters

The <Custom_name> may consist of ASCII characters and can be 32 characters long. Longer names are truncated.

Example

- ▶ SET /SYS/MB.DeviceLabel=Enc_80
- ◀ pw /SYS/MB.DeviceLabel=Enc_80

6.4.3. Querying the Serial Number

Command and Response

- ▶ GET /.SerialNumber
- ◀ pr /.SerialNumber=<serial_nr>

Example

- ▶ GET /.SerialNumber
- ◀ pr /.SerialNumber=87654321

6.4.4. Querying the Package Version

Command and Response #firmwareversion

- ▶ GET /SYS/MB.PackageVersion
- ◀ pr /SYS/MB.PackageVersion=<package_version>

Example

- ▶ GET /SYS/MB.PackageVersion
- ◀ pr /SYS/MB.PackageVersion=v1.4.0b7 r90

6.4.5. Resetting the Device

The extender can be restarted; the current connections (RS-232, USB, etc...) will be terminated.

Command and Response #reboot #restart #reset

- ▶ CALL /SYS:reset()
- ◀ m0 /SYS:Reset

Example

- ▶ CALL /SYS:reset()
- ◀ m0 /SYS:reset

6.4.6. Restoring the Factory Default Settings

Command and Response #factory

- ▶ CALL /SYS:factoryDefaults()
- ◀ m0 /SYS:factoryDefaults=

Example

- ▶ CALL /SYS:factoryDefaults()
- ◀ m0 /SYS:factoryDefaults=

The device is restarted, the current connections are terminated, the default settings are restored. See the complete list in the [Factory Default Settings](#) section.

6.5. Cleartext Login Protection

DIFFERENCE: This feature is available from firmware v3.1.0.

This cleartext login tool allows setting a password for login, thus the device will not accept any command coming from a control interface (LW3, Ethernet, etc...) without login. The device will be visible in the Device Discovery window (as the device type and the serial number can be queried without login) but connection can be established only after successful login. The login is valid until a TCP socket break in case of Ethernet connection. `#login`

ATTENTION! If the login is enabled, the built-in miniweb will also require the password upon entering.

INFO: The login password is erased and the login is disabled when restoring the factory default values.

The following can be queried without login:

- ProductName
- PartNumber
- SerialNumber
- FirmwareVersion
- PackageVersion
- MacAddress

6.5.1. Setting the Login Password

Command and Response

- ▶ `CALL /LOGIN:setPassword(<password>)`
- ◀ `mO /LOGIN:setPassword`

Example

- ▶ `CALL /LOGIN:setPassword(pr0t3ctED)`
- ◀ `mO /LOGIN:setPassword`

The password may contain uppercase (A-Z) and lowercase (a-z) letters of the English alphabet, as well as numbers (0-9). The minimum length of a password is four characters.

6.5.2. Logging into the Device

Command and Response

- ▶ `CALL /LOGIN:login(<password>)`
- ◀ `mO /LOGIN:login`

Example

- ▶ `CALL /LOGIN:login(pr0t3ctED)`
- ◀ `mO /LOGIN:login`

After a successful login, the **LoggedIn** property becomes **true** and the LW3 tree is available.

6.5.3. Logging out of the Device

Command and Response

- ▶ `CALL /LOGIN:logout(<password>)`
- ◀ `mO /LOGIN:logout`

Example

- ▶ `CALL /LOGIN:logout(pr0t3ctED)`
- ◀ `mO /LOGIN:logout`

After a successful logout, the **LoggedIn** property becomes **false** and the LW3 tree is protected. Please note the logging out is only possible if the Cleartext login function is **enabled**.

6.5.4. Enabling/Disabling the Cleartext Login Function

ATTENTION! This property can be changed only, if the **LoggedIn** property is **true**.

Command and Response

- ▶ `SET /LOGIN:LoginEnable=<login_state>`
- ◀ `pw /LOGIN.LoginEnable=<login_state>`

Parameters

If the `<login_state>` parameter is **true** (or **1**), the Cleartext login function is **enabled**, if the parameter is **false** (or **0**), the function is **disabled**. Please note that the function can be enabled without setting a password by the **setPassword** method.

Example

- ▶ `SET /LOGIN.LoginEnable=true`
- ◀ `pw /LOGIN.LoginEnable=true`

6.6. Network Configuration

ATTENTION! When you change a network property, the new value is stored, but the `applySettings` method must be called always to apply the new settings. When two or more serial parameters are changed, the `applySettings` method is enough to be called once as a final step; it results in the rebooting of the extender.

6.6.1. Querying the IP Address

Command and Response *#network #ipsettings #dhcp*

- ▶ GET•/MANAGEMENT/NETWORK.IpAddress
- ◀ pr•/MANAGEMENT/NETWORK.IpAddress=<IP_Address>

Example

- ▶ GET /MANAGEMENT/NETWORK.IpAddress
- ◀ pr /MANAGEMENT/NETWORK.IpAddress=192.168.0.100

6.6.2. Querying the IP Setup Mode (FW 2.x.x)

DIFFERENCE: The following command is valid with firmware package 2.0.0 or newer.

Command and Response

- ▶ GET•/MANAGEMENT/NETWORK.IpSetupMode
- ◀ pw•/MANAGEMENT/NETWORK.IpSetupMode=<IP_mode>

Parameters

Identifier	Parameter description	Parameter values
<IP_mode>	The currently applied IP setup mode.	<p>static: using a static IP address, gateway and subnet mask entered by the user.</p> <p>autoip: generating an IP address from the AutoIP range (169.254.x.x), even if a DHCP server is available.</p> <p>dhcponeshot: trying to get the IP address, gateway and subnet mask from a DHCP server. If no answer arrives, fallback to autoIP.</p> <p>dhcpwautoip: (factory default setting) similar to dhcponeshot, but keep on with DHCP discovery queries even after AutoIP fallback. If there is a DHCP response, the IP parameters are set accordingly.</p> <p>dhcpwoautoip: try to get the IP address, gateway and subnet mask from a DHCP server without ever falling back to AutoIP mode.</p>

Example

- ▶ GET /MANAGEMENT/NETWORK.IpSetupMode
- ◀ pw /MANAGEMENT/NETWORK.IpSetupMode=static

Explanation

Static IP address (fix IP) setting is valid.

6.6.3. Setting the IP Setup Mode (FW 2.x.x)

DIFFERENCE: The following command is valid with firmware package 2.x.x.

Command and Response

- ▶ SET•/MANAGEMENT/NETWORK.IpSetupMode
- ◀ pw•/MANAGEMENT/NETWORK.IpSetupMode=<IP_mode>

Parameters

See the previous section.

Example

- ▶ SET /MANAGEMENT/NETWORK.IpSetupMode=autoip
- ◀ pw /MANAGEMENT/NETWORK.DhcpEnabled=autoip
- ▶ CALL /MANAGEMENT/NETWORK:applySettings(1)
- ◀ mO /MANAGEMENT/NETWORK:applySettings

INFO: The `applySettings` method will save and apply the new value, and results in the rebooting of the extender.

Explanation

The IP address is set in the 169.254.x.x range by the extender based on Auto IP (Automatic Private IP Addressing) method.

6.6.4. Querying the DHCP State (FW 1.x.x)

DIFFERENCE: The following command is valid with firmware package 1.x.x.

Command and Response

- ▶ GET•/MANAGEMENT/NETWORK.DhcpEnabled
- ◀ pw•/MANAGEMENT/NETWORK.DhcpEnabled=<DHCP_state>

Parameters

If the <DHCP_state> parameter is **0** (or **false**), the device is set to apply a static IP address. If the value is **1** (or **true**), the device is set to get a dynamic IP address from the DHCP server in the network.

Example

- ▶ GET /MANAGEMENT/NETWORK.DhcpEnabled
- ◀ pw /MANAGEMENT/NETWORK.DhcpEnabled=true

Explanation

The IP address assignment is dynamic, the device gets the IP address from the DHCP server.

6.6.5. Setting the DHCP State (FW 1.x.x)

DIFFERENCE: The following command is valid with firmware package 1.x.x.

Command and Response

- ▶ SET /MANAGEMENT/NETWORK.DhcpEnabled=<DHCP_state>
- ◀ pw /MANAGEMENT/NETWORK.DhcpEnabled=<DHCP_state>

Parameters

See the previous section.

Example

- ▶ SET /MANAGEMENT/NETWORK.DhcpEnabled=0
- ◀ pw /MANAGEMENT/NETWORK.DhcpEnabled=false
- ▶ CALL /MANAGEMENT/NETWORK:applySettings(1)
- ◀ mO /MANAGEMENT/NETWORK:applySettings

INFO: The **applySettings** method will save and apply the new value, and results in the rebooting of the extender.

Explanation

The IP address assignment is set to static, thus you have to set it manually.

6.6.6. Setting a Static IP Address

DIFFERENCE: Make sure the IP address setting is static:
 In case of FW 1.x.x: when the **DhcpEnabled** property is **false**, you can set a static IP address.
 In case of FW 2.x.x: when the **IpSetupMode** property is **static**, you can set a static IP address.

Command and Response

- ▶ SET /MANAGEMENT/NETWORK.StaticIpAddress=<IP_address>
- ◀ pw /MANAGEMENT/NETWORK.StaticIpAddress=<IP_address>

Example

- ▶ SET /MANAGEMENT/NETWORK.StaticIpAddress=192.168.0.85
- ◀ pw /MANAGEMENT/NETWORK.StaticIpAddress=192.168.0.85
- ▶ CALL /MANAGEMENT/NETWORK:applySettings(1)
- ◀ mO /MANAGEMENT/NETWORK:applySettings

INFO: The **applySettings** method will save and apply the new value, and results in the rebooting of the extender.

6.6.7. Querying the Subnet Mask

Command and Response

- ▶ GET /MANAGEMENT/NETWORK.NetworkMask
- ◀ pr /MANAGEMENT/NETWORK.NetworkMask=<subnet_mask>

Example

- ▶ GET /MANAGEMENT/NETWORK.NetworkMask
- ◀ pr /MANAGEMENT/NETWORK.NetworkMask=255.255.255.0

6.6.8. Setting a Static Subnet Mask

DIFFERENCE: Make sure the IP address setting is static:
 In case of FW 1.x.x: when the **DhcpEnabled** property is **false**, you can set a static IP address.
 In case of FW 2.x.x: when the **IpSetupMode** property is **static**, you can set a static IP address.

Command and Response

- ▶ SET /MANAGEMENT/NETWORK.StaticNetworkMask=<subnet_mask>
- ◀ pw /MANAGEMENT/NETWORK.StaticNetworkMask=<subnet_mask>

Example

- ▶ SET /MANAGEMENT/NETWORK.StaticNetworkMask=255.255.255.0
- ◀ pw /MANAGEMENT/NETWORK.StaticNetworkMask=255.255.255.0
- ▶ CALL /MANAGEMENT/NETWORK:applySettings(1)
- ◀ mO /MANAGEMENT/NETWORK:applySettings

INFO: The **applySettings** method will save and apply the new value, and results in the rebooting of the extender.

6.6.9. Querying the Gateway Address

Command and Response

- ▶ GET /MANAGEMENT/NETWORK.GatewayAddress
- ◀ pr /MANAGEMENT/NETWORK.GatewayAddress=<gw_address>

Example

- ▶ GET /MANAGEMENT/NETWORK.GatewayAddress
- ◀ pr /MANAGEMENT/NETWORK.GatewayAddress=192.168.0.1

6.6.10. Setting a Static Gateway Address

DIFFERENCE: Make sure the IP address setting is static:

In case of FW 1.x.x: when the `DhcpEnabled` property is **false**, you can set a static IP address.

In case of FW 2.x.x: when the `IpSetupMode` property is **static**, you can set a static IP address.

Command and Response

- ▶ `SET /MANAGEMENT/NETWORK.StaticGatewayAddress=<gateway_address>`
- ◀ `pw /MANAGEMENT/NETWORK.StaticGatewayAddress=<gateway_address>`

Example

- ▶ `SET /MANAGEMENT/NETWORK.StaticGatewayAddress=192.168.0.5`
- ◀ `pw /MANAGEMENT/NETWORK.StaticGatewayAddress=192.168.0.5`
- ▶ `CALL /MANAGEMENT/NETWORK:applySettings(1)`
- ◀ `mO /MANAGEMENT/NETWORK:applySettings`

INFO: The `applySettings` method will save and apply the new value, and results in the rebooting of the extender.

6.7. Encoder-related Commands

6.7.1. Querying the Input Video Signal Presence

The input port can be queried if video signal is present.

Command and Response *#status*

- ▶ `GET /MEDIA/VIDEO/<in>.SignalPresent`
- ◀ `pr /MEDIA/VIDEO/<in>.SignalPresent=<signal_present>`

Parameters

If the `<signal_present>` parameter is **0**, then signal is not present at the port. If the value is **1**, then signal is present at the input.

Example

- ▶ `GET /MEDIA/VIDEO/I1.SignalPresent`
- ◀ `pr /MEDIA/VIDEO/I1.SignalPresent=1`

6.7.2. Querying the Resolution of the Input Video Signal

The resolution and the refresh rate of the incoming video signal can be queried.

Command and Response *#resolution*

- ▶ `GET /MEDIA/VIDEO/<in>.Resolution`
- ◀ `pr /MEDIA/VIDEO/<in>.Resolution=<resolution@refresh_rate>`

Example

- ▶ `GET /MEDIA/VIDEO/I1.Resolution`
- ◀ `pr /MEDIA/VIDEO/I1.Resolution=1280x720@60Hz`

6.7.3. Querying the Active Input Port

DIFFERENCE: The command below is valid for VINX-210AP-HDMI-ENC device only.

Command and Response

- ▶ `GET /MEDIA/VIDEO.InputSource`
- ◀ `pr /MEDIA/VIDEO.InputSource=<source_ID>`

Parameters

Identifier	Parameter description	Parameter values
<source_ID>	Identifier of the video input port	0: unknown 1: HDMI 2: VGA

Example

- ▶ `GET /MEDIA/VIDEO.InputSource`
- ◀ `pr /MEDIA/VIDEO.InputSource=1`

6.7.4. Querying the Video Input Selection Mode

DIFFERENCE: The command below is valid for VINX-210AP-HDMI-ENC device only.

Command and Response *#inputselection*

- ▶ `GET /MEDIA/VIDEO.SelectionMode`
- ◀ `pw /MEDIA/VIDEO.SelectionMode=<sel_mode>`

Parameters

Identifier	Parameter description	Parameter values
<sel_mode>	The currently applied input selection method.	0: Auto 1: HDMI 2: VGA

Auto mode: the first connected source shall remain active as long as signal is present on the respective input. If sync is lost for at least 3 seconds, a switch over to the other source shall occur. No automatic switch back to the original input shall occur when the signal is restored.

Example

- ▶ `GET /MEDIA/VIDEO.SelectionMode`
- ◀ `pw /MEDIA/VIDEO.SelectionMode=0`

6.7.5. Setting the Video Input Selection Mode

DIFFERENCE: The command below is valid for VINX-210AP-HDMI-ENC device only.

Command and Response

- ▶ SET•/MEDIA/VIDEO.SelectionMode=<sel_mode>
- ◀ pw•/MEDIA/VIDEO.SelectionMode=<sel_mode>

Parameters

Identifier	Parameter description	Parameter values
<sel_mode>	The currently applied input selection method.	0: Auto (see the details in previous section) 1: HDMI 2: VGA

Example

- ▶ SET /MEDIA/VIDEO.SelectionMode=1
- ◀ pw /MEDIA/VIDEO.SelectionMode=1

6.7.6. Querying the Video Quality Mode

When the network bandwidth is not enough to transmit the video signal, the following modes are available in the Encoder:

- **Movie mode** (Lower image quality @ Less bandwidth): The image quality is adjusted to the available bandwidth. If the bandwidth is decreased, the image quality will be lower, but the video streaming is continuous.
- **Graphics mode** (Best image quality @ High bandwidth): The image quality is kept at a high level. If the bandwidth is decreased, the image quality does not change, but frame drop may appear.

Command and Response *#qualitymode #videoquality*

- ▶ GET•/MEDIA/VIDEO/QUALITY.QualityMode
- ◀ pw•/MEDIA/VIDEO/QUALITY.QualityMode=<quality_mode>

Parameters

The value of the <quality_mode> parameter shows the current mode setting: **movie** or **graphic**.

Example

- ▶ GET /MEDIA/VIDEO/QUALITY.QualityMode
- ◀ pw /MEDIA/VIDEO/QUALITY.QualityMode=movie

6.7.7. Setting the Video Quality Mode

The video quality mode can be set in the Encoder (see the previous section for details about the modes):

Command and Response

- ▶ SET•/MEDIA/VIDEO/QUALITY.QualityMode=<quality_mode>
- ◀ pw•/MEDIA/VIDEO/QUALITY.QualityMode=<quality_mode>

Parameters

See the previous section.

Example

- ▶ SET /MEDIA/VIDEO/QUALITY.QualityMode=graphic
- ◀ pw /MEDIA/VIDEO/QUALITY.QualityMode=graphic

6.7.8. Querying the HDCP State

The current state of the HDCP encryption can be queried at the input port; see the [HDCP Management](#) section.

Command and Response *#hdcpc*

- ▶ GET•/MEDIA/VIDEO/<in>.HdcpState
- ◀ pr•/MEDIA/VIDEO/<in>.HdcpState=<HDCP_state>

Parameters

If the <HDCP_state> parameter is **0**, then the HDCP encryption is disabled at the port. If the value is **1**, then HDCP encryption is enabled.

Example

- ▶ GET /MEDIA/VIDEO/I1.HdcpState
- ◀ pr /MEDIA/VIDEO/I1.HdcpState=1

6.7.9. Setting the HDCP State

HDCP capability can be enabled/disabled on the input port of the Encoder, thus non-encrypted content can be seen on a non-HDCP compliant display if the content allows it; see the [HDCP Management](#) section.

Command and Response

- ▶ SET•/MEDIA/VIDEO/<in>.HdcpEnable=<HDCP_state>
- ◀ pw•/MEDIA/VIDEO/<in>.HdcpEnable=<HDCP_state>

ATTENTION! When you change this property, the **applySettings** method must be called always to store the new setting. If the HDCP State is changed, the device is restarted automatically.

Parameters

See the previous section.

Example

- ▶ SET /MEDIA/VIDEO/I1.HdcpEnable=0
- ◀ pw /MEDIA/VIDEO/I1.HdcpEnable=false
- ▶ CALL /MEDIA/VIDEO/I1:applySettings()
- ◀ mO /MEDIA/VIDEO/I1:applySettings

ATTENTION! The EDID information cannot be read by the source attached to the HDMI input of an Encoder if HDCP is disabled on the input. That may stop the video transmission in the case of certain source devices.

6.7.10. Force HDCP Version

DIFFERENCE: This command is available from firmware version v3.3.1.

You can set the version of HDCP encryption with this parameter on decoders.

Command and Response

- ▶ SET•/MEDIA/VIDEO/<out>.ForceHDCP=<hdcp_version>
- ◀ pw•/MEDIA/VIDEO/<out>.ForceHDCP=<hdcp_version>

ATTENTION! When you change this property, the **applySettings** method must be called always to store the new setting. If the HDCP State is changed, the device is restarted automatically.

Parameters

Identifier	Parameter description	Parameter values
<hdcp_version>	The HDCP version to be forced on the output signal.	1: HDCP 1.4 2: HDCP 2.2

Example

- ▶ SET /MEDIA/VIDEO/O1.ForceHDCP=2
- ◀ pw /MEDIA/VIDEO/O1.ForceHDCP=2

6.8. Decoder-related Commands

6.8.1. Querying the Resolution of the Output Video Signal

The resolution and the refresh rate of the outgoing video signal can be queried.

Command and Response #resolution

- ▶ GET•/MEDIA/VIDEO/<out>.Resolution
- ◀ pr•/MEDIA/VIDEO/<out>.Resolution=<resolution@refresh_rate>

Example

- ▶ GET /MEDIA/VIDEO/O1.Resolution
- ◀ pr /MEDIA/VIDEO/O1.Resolution=1600x1200@60Hz

6.8.2. Querying the Scaling Mode of the Output Video Signal

Command and Response #scaler

- ▶ GET•/MEDIA/VIDEO/<out>/SCALER.ScalingMode
- ◀ pw•/MEDIA/VIDEO/<out>/SCALER.ScalingMode=<sc_mode>

Parameters

Identifier	Parameter description	Parameter values
<sc_mode>	Scaling mode	OFF: Scaling is disabled, the resolution is not changed. EDID: the resolution is set to meet with the preferred timing of the sink device. MANUAL: Scaling is set manually.

Example

- ▶ GET /MEDIA/VIDEO/O1/SCALER.ScalingMode
- ◀ pw /MEDIA/VIDEO/O1/SCALER.ScalingMode=MANUAL

See more information about the scaling modes in the [Main Settings \(Decoder\)](#) section.

6.8.3. Setting the Scaling Mode of the Output Video Signal

Command and Response

- ▶ SET•/MEDIA/VIDEO/<out>/SCALER.ScalingMode=<sc_mode>
- ◀ pw•/MEDIA/VIDEO/<out>/SCALER.ScalingMode=<sc_mode>

Parameters

See the previous section.

Example

- ▶ SET /MEDIA/VIDEO/O1/SCALER.ScalingMode=OFF
- ◀ pw /MEDIA/VIDEO/O1/SCALER.ScalingMode=OFF

See more information about the scaling modes in the [Main Settings \(Decoder\)](#) section.

6.8.4. Querying the Signal Type of the Output Video Signal

Command and Response *#signaltype*

- ▶ GET•/MEDIA/VIDEO/<out>/SCALER.SignalType
- ◀ pw•/MEDIA/VIDEO/<out>/SCALER.SignalType=<sig_type>

Parameters

The <sig_type> can be **DVI** or **HDMI**.

Example

- ▶ **GET /MEDIA/VIDEO/01/SCALER.SignalType**
- ◀ **pw /MEDIA/VIDEO/01/SCALER.SignalType=HDMI**

6.8.5. Setting the Resolution of the Output Video Signal

The resolution and the refresh rate of the outgoing video signal can be set.

Command and Response

- ▶ SET•/MEDIA/VIDEO/<out>/SCALER.OutputResolution
- ◀ pw•/MEDIA/VIDEO/<out>/SCALER.OutputResolution=<Resolution_code>

Parameters

The <Resolution_code> is an 8-character long code covering the scaled resolution and refresh rate. The complete list can be found in the [Supported Resolutions](#) section.

Example

- ▶ **SET /MEDIA/VIDEO/01/SCALER.OutputResolution=81004088**
- ◀ **pw /MEDIA/VIDEO/01/SCALER.OutputResolution=81004088**

Explanation

The new value of the parameter is 81004088, which means the resolution of the output signal is set to 1280x720@60Hz.

ATTENTION! Set the **ScalingMode** property to **MANUAL** after changing the **Resolution** property manually to apply the new settings.

6.8.6. Rotating the screen

The position of the screen on the display can be changed with this command.

Command and Response

- ▶ SET•/MEDIA/VIDEO/<out>/VIDEOWALL.Rotation=<value>
- ◀ pw•/MEDIA/VIDEO/<out>/VIDEOWALL.Rotation=<value>

Parameters

The <value> can be set to **0** (default, no rotation), **1** (flip vertically), **2** (flip horizontally), **3** (rotate 180 degrees), **5** (rotate 90 degrees) and **6** (rotate 270 degrees). Please note that values **4** and **7** are not supported and break the screen on display.

Example

- ▶ **SET /MEDIA/VIDEO/01/VIDEOWALL.Rotation=1**
- ◀ **pw /MEDIA/VIDEO/01/VIDEOWALL.Rotation=1**

■ **INFO:** Rotation only applies to the output video signal, it has no effect on the Custom Logo, if one is set.

6.8.7. Setting the No-signal-screen

If there is no video signal, the VINX screen is shown on the output; this can be changed with this command.

Command and Response

- ▶ SET•/MEDIA/VIDEO/<out>.EnableVinxGui=<vinx_gui>
- ◀ pw•/MEDIA/VIDEO/<out>.EnableVinxGui=<vinx_gui>

■ **ATTENTION!** When you change this property, the **applySettings** method must be called always to store the new setting, which makes the device reboot.

Parameters

If the <vinx_gui> parameter is **true** or **1**, the VINX screen is shown. If the parameter is **false** or **0**, black screen is shown.

Example

- ▶ **SET /MEDIA/VIDEO/01.EnableVinxGui=1**
- ◀ **pw /MEDIA/VIDEO/01.EnableVinxGui=true**
- ▶ **CALL /MEDIA/VIDEO/01:applySettings(1)**
- ◀ **<reboot>**

6.8.8. Setting the State of the Output

This command allows turning off an output either manually or automatically by disabling the +5V sending feature.

Command and Response

- ▶ SET•/MEDIA/VIDEO/<out>.OutputEnabled=<output_state>
- ◀ pw•/MEDIA/VIDEO/<out>.OutputEnabled=<output_state>

Parameters

Identifier	Parameter description	Parameter values
<output_state>	The method of turning off an output..	1: auto 2: off

If the <output_state> is set as **auto** (or 1), the system will automatically determine whether to send +5V based on the settings of the custom logo function. If the <output_state> is **off** (or 2), the output will not send +5V towards the connected display.

Example

- ▶ SET /MEDIA/VIDEO/O1.OutputEnabled=auto
- ◀ pw /MEDIA/VIDEO/O1.OutputEnabled=auto

6.8.9. Setting the Delay of Muting the Audio During Switching

ATTENTION! Please note this command is for debugging purposes, if you encounter switching problems in big systems. Under normal circumstances, leave as default.

INFO: Switch order setting can be applied only if the the Free routing is enabled. See the details about it in the [Using of Free Routing](#) section.

This property sets the delay of muting the audio while switching the signal in milliseconds. Default is 3 seconds (3000 milliseconds).

Command and Response

- ▶ SET•/SYS/MB/PHY.AudioMuteDelay=<delay_time>
- ◀ pw•/SYS/MB/PHY.AudioMuteDelay=<delay_time>

Example

- ▶ SET /SYS/MB/PHY.AudioMuteDealy=4000
- ◀ pw /SYS/MB/PHY.AudioMuteDelay=4000

ATTENTION! When you change this property, the **applySettings** method must be called always to store the new setting, which makes the device reboot.

6.8.10. Setting the Switch Order

ATTENTION! Please note this command is for debugging purposes, if you encounter switching problems in big systems. Under normal circumstances, leave as default.

INFO: Switch order setting can be applied only if the the Free routing is enabled. See the details about it in the [Using of Free Routing](#) section.

You can determine the order of switching the signal layers. All decoders must have the same value.

Command and Response

- ▶ SET•/SYS/MB/PHY.SwitchOrder=<order>
- ◀ pw•/SYS/MB/PHY.SwitchOrder=<order>

Parameters

Identifier	Parameter description	Parameter values
<order>	The switching order of the signal layers.	0: all-in-one 1: video, sleep1, audio, sleep1, others 2: audio, sleep1, video, sleep1, others 3: audio, sleep2, video, sleep1, others 4: video, audio, sleep2, others

Example

- ▶ SET /SYS/MB/PHY.SwitchOrder=2
- ◀ pw /SYS/MB/PHY.SwitchOrder=2

ATTENTION! When you change this property, the **applySettings** method must be called always to store the new setting, which makes the device reboot.

6.8.11. Using of Free Routing

ATTENTION! Please note this command is for debugging purposes, if you encounter switching problems in big systems. Under normal circumstances, leave as default.

This command allows to pack the different layers of the signal into different multicast groups before forwarding it. This is a system-wide parameter, every endpoint needs to be set to the same value. It is disabled by default.

Command and Response

- ▶ SET•/MANAGEMENT/MULTICAST/FreeRoute=<freeroute_state>
- ◀ pw•/MANAGEMENT/MULTICAST/FreeRoute=<freeroute_state>
- ▶ SET•/MANAGEMENT/MULTICAST/FreeRouteMap=<freeroute_value>
- ◀ pw•/MANAGEMENT/MULTICAST/FreeRouteMap=<freeroute_value>

Parameters

Identifier	Parameter description	Parameter values
<freeroute_state>	State of the free route mode	Enabled Disabled
<freeroute_value>	The value of the free route	2: video 3: audio 4: infra 5: serial 6: GPIO 7: USB

Example

- ▶ SET•/MANAGEMENT/MULTICAST/FreeRoute=true
- ◀ pw•/MANAGEMENT/MULTICAST/FreeRoute=true
- ▶ SET•/MANAGEMENT/MULTICAST/FreeRouteMap=2:3:4:4:4
- ◀ pw•/MANAGEMENT/MULTICAST/FreeRouteMap=2:3:4:4:4

The video and the audio are sent as separate packages, and all other layers are sent to the same multicast group.

6.9. Custom Logo Management

6.9.1. Querying the Storage Size

The storage size available for uploading custom images can be queried.

Command and Response

- ▶ GET•/MANAGEMENT/CUSTOMLOGO.StorageSize=
- ◀ pr•/MANAGEMENT/CUSTOMLOGO.StorageSize=<storage_size>

Example

- ▶ GET /MANAGEMENT/CUSTOMLOGO.StorageSize=
- ◀ pr /MANAGEMENT/CUSTOMLOGO.StorageSize=1500

6.9.2. Querying the Free Storage Size

The currently available storage size for uploading custom images can be queried.

Command and Response

- ▶ GET•/MANAGEMENT/CUSTOMLOGO/StorageFreeSize=
- ◀ pr•/MANAGEMENT/CUSTOMLOGO/StorageFreeSize=<storage_free_size>

Example

- ▶ GET /MANAGEMENT/CUSTOMLOGO/StorageFreeSize=
- ◀ pr /MANAGEMENT/CUSTOMLOGO/StorageFreeSize=864

6.9.3. Querying the Number of Uploaded Files

The number of custom image files uploaded to the device can be queried.

Command and Response

- ▶ GET•/MANAGEMENT/CUSTOMLOGO.FileCount=
- ◀ pr•/MANAGEMENT/CUSTOMLOGO.FileCount=<file_count>

Example

- ▶ GET /MANAGEMENT/CUSTOMLOGO.FileCount=
- ◀ pr /MANAGEMENT/CUSTOMLOGO.FileCount=3

6.9.4. Querying the List of Uploaded Files

The list of the files uploaded to the device can be queried.

Command and Response

- ▶ GET•/MANAGEMENT/CUSTOMLOGO.FileList=
- ◀ pr•/MANAGEMENT/CUSTOMLOGO.FileList=<file_list>

Example

- ▶ GET /MANAGEMENT/CUSTOMLOGO.FileList=
- ◀ pr /MANAGEMENT/CUSTOMLOGO.FileList=detroit.jpg, intro_1641507027.jpg, sunset_hd_background_photos_12_scaled.jpg

6.9.5. Deleting a Custom Image

The custom image files on the device can be deleted.

Command and Response

- ▶ CALL•/MANAGEMENT/CUSTOMLOGO:DeleteFile(<file_name>)
- ◀ mO•/MANAGEMENT/CUSTOMLOGO:DeleteFile

Example

- ▶ CALL /MANAGEMENT/CUSTOMLOGO:DeleteFile(detroit.jpg)
- ◀ mO /MANAGEMENT/CUSTOMLOGO:DeleteFile

6.9.6. Selecting a Custom Logo - No Connection to the Encoder

The logo to be shown when there is no connection with the encoder can be set here.

Command and Response

- ▶ SET•/MEDIA/VIDEO/<out>.NoConnectionLogo=<file_name>
- ◀ CHG•/MEDIA/VIDEO/<out>.NoConnectionLogo=<file_name>

Example

- ▶ SET /MEDIA/VIDEO/O1.NoConnectionLogo=intro_1641507027.jpg
- ◀ pw /MEDIA/VIDEO/O1.NoConnectionLogo=intro_1641507027.jpg

6.9.7. Selecting a Custom Logo - No Active Video Signal

The logo to be shown when there is no incoming video signal can be set here.

Command and Response

- ▶ SET•/MEDIA/VIDEO/<out>.NoVideoLogo=<file_name>
- ◀ CHG•/MEDIA/VIDEO/<out>.NoVideoLogo=<file_name>

Example

- ▶ SET /MEDIA/VIDEO/O1.NoVideoLogo=intro_1641507027.jpg
- ◀ pw /MEDIA/VIDEO/O1.NoVideoLogo=intro_1641507027.jpg

6.9.8. Selecting a Custom Logo to Be Forced Over the Active Video

You can set a custom logo to be shown over an active video signal here.

Command and Response

- ▶ CALL•/MEDIA/VIDEO/<out>.forceShowCustomLogo=(<file_name>)
- ◀ mO•/MEDIA/VIDEO/<out>.forceShowCustomLogo

Example

- ▶ CALL /MEDIA/VIDEO/O1.forceShowCustomLogo=detroit.jpg
- ◀ mO /MEDIA/VIDEO/O1.forceShowCustomLogo

INFO: In this case the **IsLogoForced** parameter becomes **true** and the file name will appear in the **ForcedLogo** property. If there is no custom logo forced over the video, the **IsLogoForced** parameter is **false** and the **ForcedLogo** property is empty.

6.9.9. Setting the Status of the Information Text

You can change whether to display the information text over the custom logo screen or not.

Command and Response

- ▶ SET•/MEDIA/VIDEO/<out>.ShowInfoText=<switch_valid>
- ◀ pw•/MEDIA/VIDEO/<out>.ShowInfoText=<switch_valid>

Parameters

If the <switch_valid> parameter is **0** (or **false**), the information text will not be shown on the custom logo screen. If the value is **1** (or **true**), the information text will appear at the bottom of the custom logo screen.

Example

- ▶ SET /MEDIA/VIDEO/O1.ShowInfoText=true
- ◀ pw /MEDIA/VIDEO/O1.ShowInfoText=true

6.9.10. Setting the Signal Type of the Output Video Signal

Command and Response

- ▶ SET•/MEDIA/VIDEO/<out>/SCALER.SignalType=<sig_type>
- ◀ pw•/MEDIA/VIDEO/<out>/SCALER.SignalType=<sig_type>

Parameters

See the previous section.

Example

- ▶ SET /MEDIA/VIDEO/01/SCALER.SignalType=HDMI
- ◀ pw /MEDIA/VIDEO/01/SCALER.SignalType=HDMI

INFO: The property takes effect only when the **ScalingMode** property is set to **MANUAL** setting.

6.9.11. Querying the State of the USB Connection

When the extenders are in **Multicast mode**, the USB transmission has to be determined by selecting the active Decoder. To query the current state of a given Decoder, use the following command:

Command and Response *#usbkvm #kvm*

- ▶ GET•/MEDIA/KM.Controlling
- ◀ pr•/MEDIA/KM.Controlling=<USB_state>

Parameters

If the <USB_state> parameter is **0** (or **false**), there is no USB data transmission to/from an Encoder. If the value is **1** (or **true**), the USB data transmission is enabled and the Decoder is connected to an Encoder.

Example

- ▶ GET /MEDIA/KM.Controlling
- ◀ pr /MEDIA/KM.Controlling=false

See more information about the USB features in the [USB Interface](#) section.

6.9.12. Establishing the USB Connection

When the extenders are in **Multicast mode**, the USB transmission has to be determined by selecting the active Decoder. To establish the connection between the Decoder and the Encoder, use the following command:

Command and Response

- ▶ CALL•/MEDIA/KM:acquireControl(true)
- ◀ mO•/MEDIA/KM:acquireControl

Example

- ▶ CALL /MEDIA/KM:acquireControl(1)
- ◀ mO /MEDIA/KM:acquireControl

ATTENTION! Establishing the connection to a Decoder will disconnect the USB transmission of the previously connected Decoder.

6.10. Audio-related Commands

DIFFERENCE: The following commands refer to the AP-series only.

The port numbering is a required parameter in most cases. See the details in the [Audio Port Numbering](#) section. *#audio*

6.10.1. Querying the Audio Input Selection Mode

Command and Response

- ▶ GET•/MEDIA/AUDIO.ioSelect
- ◀ pw•/MEDIA/AUDIO.ioSelect=<sel_mode>

Parameters

Identifier	Parameter description	Parameter values
<sel_mode>	The currently applied audio input selection method.	0: unknown 1: HDMI 2: analog 3: auto1 4: auto2

- **auto1:** the analog audio input port is selected when a plug is connected.
- **auto2:** the selection follows the video input setting:
 - When HDMI is selected as the video source, the audio of the original HDMI stream is transmitted.
 - When VGA is selected as the video source, the analog audio is transmitted.

INFO: **auto2** mode is available in VINX-210AP-HDMI-ENC device only.

Example

- ▶ GET /MEDIA/AUDIO.ioSelect
- ◀ pw /MEDIA/AUDIO.ioSelect=1

6.10.2. Setting the Audio Input Selection Mode

Command and Response

- ▶ SET•/MEDIA/AUDIO.ioSelect=<sel_mode>
- ◀ pw•/MEDIA/AUDIO.ioSelect=<sel_mode>

Parameters

See the previous section.

Example

- ▶ SET /MEDIA/AUDIO.ioSelect
- ◀ pw /MEDIA/AUDIO.ioSelect=2

6.10.3. Querying the Audio Signal Presence

Command and Response

- ▶ GET•/MEDIA/AUDIO/<in>.SignalPresent
- ◀ pr•/MEDIA/AUDIO/<in>.SignalPresent=<signal_present>

Parameters

If the <signal_present> parameter is **0 or false**, then signal is not present at the port. If the value is **1 or true**, then signal is present at the input.

■ INFO: In the case of analog audio ports, the value of the parameter is 1 when a plug is connected.

Example

- ▶ GET /MEDIA/AUDIO/I1.SignalPresent
- ◀ pr /MEDIA/AUDIO/I1.SignalPresent=false

6.11. Analog Audio Input/Output Signal Level Settings

6.11.1. Querying the Volume (Exact Value)

Command and Response *#analogaudio #volume*

- ▶ GET•/MEDIA/AUDIO/<port>.AnalogVolumedB
- ◀ pw•/MEDIA/AUDIO/<port>.AnalogVolumedB=<value>

Parameters

The response <value> is in dB.

Example

- ▶ GET /MEDIA/AUDIO/I2.AnalogVolumedB
- ◀ pw /MEDIA/AUDIO/I2.AnalogVolumedB=-20.00

6.11.2. Setting the Volume (Exact Value)

Command and Response

- ▶ SET•/MEDIA/AUDIO/<port>.AnalogVolumedB=<value>
- ◀ pw•/MEDIA/AUDIO/<port>.AnalogVolumedB=<value>

Parameters

The <value> is in dB and the accepted values are between -44 and 0.

Example

- ▶ SET /MEDIA/AUDIO/I2.AnalogVolumedB=-10
- ◀ pw /MEDIA/AUDIO/I2.AnalogVolumedB=-10.00

■ INFO: Changing the value of the property above will also change the **AnalogVolume** property accordingly.

6.11.3. Setting the Volume (by a Step Value)

Command and Response

- ▶ CALL•/MEDIA/AUDIO/<port>.stepVolumeDb(<value>)
- ◀ mO•/MEDIA/AUDIO/<port>.stepVolumeDb

Parameters

The <value> is in dB; positive and negative values are accepted.

Example

- ▶ CALL /MEDIA/AUDIO/I2.stepVolumeDb(-10.5)
- ◀ mO /MEDIA/AUDIO/I2.stepVolumeDb

Explanation

The volume of the audio signal has been decreased by 10.5 dB.

■ INFO: Calling the method above will change the **AnalogVolume** and **AnalogVolumedB** properties accordingly.

6.11.4. Querying the Volume (in Percentage)

Command and Response

- ▶ GET•/MEDIA/AUDIO/<port>.AnalogVolume
- ◀ pw•/MEDIA/AUDIO/<port>.AnalogVolume=<vol_per>

Parameters

The value of <vol_per> is defined between 0 and 100 (min and max).

Example

- ▶ GET /MEDIA/AUDIO/I2.AnalogVolume
- ◀ pw /MEDIA/AUDIO/I2.AnalogVolume=80

6.11.5. Setting the Volume (in Percentage)

Command and Response

- ▶ SET•/MEDIA/AUDIO/<port>.AnalogVolume=<value>
- ◀ pw•/MEDIA/AUDIO/<port>.AnalogVolume=<value>

Parameters

The <value> is defined in percentage. The accepted values are between 0 and 100. Higher/lower values will be rounded up/down.

Example

- ▶ SET /MEDIA/AUDIO/I2.AnalogVolume=50
- ◀ pw /MEDIA/AUDIO/I2.AnalogVolume=50

■ INFO: Changing the value of the property above will also change the **AnalogVolumedB** property accordingly.

6.11.6. Setting the Volume (by a Step Value in Percentage)

Command and Response

- ▶ CALL•/MEDIA/AUDIO/<port>:stepVolumePercent(<value>)
- ◀ mO•/MEDIA/AUDIO/<port>:stepVolumePercent

Parameters

The <value> is defined in percentage. The accepted values are between 0 and 100. Higher/lower values will be rounded up/down. Please note that the step value is calculated from 100% – see the example below:

Example

- ▶ GET /MEDIA/AUDIO/I2.AnalogVolume
- ◀ pw /MEDIA/AUDIO/I2.AnalogVolume=80
- ▶ CALL /MEDIA/AUDIO/<port>:stepVolumePercent=-10
- ◀ mO /MEDIA/AUDIO/<port>:stepVolumePercent
- ◀ CHG /MEDIA/AUDIO/O2.AnalogVolume=70

INFO: Changing the value of the property above will also change the **AnalogVolumedB** property accordingly.

6.11.7. Querying the Mute State

Command and Response #mute #unmute

- ▶ GET•/MEDIA/AUDIO/<port>.AnalogMute
- ◀ pw•/MEDIA/AUDIO/<port>.AnalogMute=<mute_state>

Parameters

If the <mute_state> parameter is **0** or **false**, then the port is **not muted**. If the value is **1** or **true**, port is **muted**.

Example

- ▶ GET /MEDIA/AUDIO/I2.AnalogMute
- ◀ pw /MEDIA/AUDIO/I2.AnalogMute=false

6.11.8. Setting the Mute State

Command and Response

- ▶ GET•/MEDIA/AUDIO/<port>.AnalogMute
- ◀ pw•/MEDIA/AUDIO/<port>.AnalogMute=<mute_state>

Parameters

See the previous section.

INFO: Changing the value of the property above to **0** or **false** will also change the **AnalogVolume** and **AnalogVolumedB** properties accordingly.

Example

- ▶ SET /MEDIA/AUDIO/I2.AnalogVolume=50
- ◀ pw /MEDIA/AUDIO/I2.AnalogVolume=50

6.12. Serial Port Settings

ATTENTION! The new port settings are stored, but only applied if the **applySettings** method is called, which will reboot the device. When two or more serial parameters are changed, the **applySettings** method is enough to be called once as a final step; it results in the rebooting of the extender.

INFO: The command listed below can be used to set the RS-232 port parameters. To query the current value of a parameter, use the GET command, e.g.: **GET /MEDIA/UART/P1.BaudRate**.

6.12.1. Setting the Port Availability

ATTENTION! The port must be enabled for the RS-232 data transmission; use this command.

Command and Response #rs232 #rs-232 #serial

- ▶ SET•/MEDIA/UART/<port>.Enabled=<port_status>
- ◀ pw•/MEDIA/UART/<port>.Enabled=<port_status>

Parameters

If the <port_status> parameter is **0** (or **false**), there is no RS-232 data transmission to/from another device. If the value is **1** (or **true**), the RS-232 data transmission is enabled.

Example

- ▶ SET /MEDIA/UART/P1.Enabled=true
- ◀ pw /MEDIA/UART/P1.Enabled=true
- ▶ CALL /MEDIA/UART/P1:applySettings(1)
- ◀ mO /MEDIA/UART/P1:applySettings

INFO: The **applySettings** method will save and apply the new value, and makes the extender reboot.

6.12.2. Setting the Baud Rate of the Port

Command and Response

- ▶ SET•/MEDIA/UART/<port>.Baudrate=<Baud_value>
- ◀ pw•/MEDIA/UART/<port>.Baudrate=<Baud_value>

Parameters

The <Baud_value> parameter can be set to: 300, 600, 1200, 2400, 4800, 9600, 19200, 38400, 57600, 115200.

Example

- ▶ SET /MEDIA/UART/P1.Baudrate=57600
- ◀ pw /MEDIA/UART/P1.Baudrate=57600
- ▶ CALL /MEDIA/UART/P1:applySettings(1)
- ◀ mO /MEDIA/UART/P1:applySettings

INFO: The **applySettings** method will save and apply the new value, and makes the extender reboot.

6.12.3. Setting the RS-232 Port Mode

The RS-232 port can be set to **Pass-through** or **Command Injection** mode. The introduction of these modes can be found in the [RS-232 Interface](#) section.

Command and Response

- ▶ SET•/MEDIA/UART/<port>.Guest=<port_mode>
- ◀ pw•/MEDIA/UART/<port>.Guest=<port_mode>

Parameters

If the <port_mode> parameter is **0** (or **false**), the mode is **Pass-through**. If the value is **1** (or **true**), the port is in **Command injection** mode; in that case, use the **6752** TCP/IP port number to address the port.

Example

- ▶ SET /MEDIA/UART/P1.Guest=false
- ◀ pw /MEDIA/UART/P1.Guest=false
- ▶ CALL /MEDIA/UART/P1:applySettings(1)
- ◀ mO /MEDIA/UART/P1:applySettings

INFO: The **applySettings** method will save and apply the new value, and makes the extender reboot.

6.12.4. Setting the Data Bits

Command and Response

- ▶ SET•/MEDIA/UART/<port>.DataBits=<Databits_value>
- ◀ pw•/MEDIA/UART/<port>.DataBits=<Databits_value>

Parameters

The <Databits_value> parameter can be set to the following values: 6, 7, 8

Example

- ▶ SET /MEDIA/UART/P1.DataBits=8
- ◀ pw /MEDIA/UART/P1.DataBits=8
- ▶ CALL /MEDIA/UART/P1:applySettings(1)
- ◀ mO /MEDIA/UART/P1:applySettings

INFO: The **applySettings** method will save and apply the new value, and makes the extender reboot.

6.12.5. Setting the Stop Bits

Command and Response

- ▶ SET•/MEDIA/UART/<port>.StopBits=<Stopbits_value>
- ◀ pw•/MEDIA/UART/<port>.StopBits=<Stopbits_value>

Parameters

The <Stopbits_value> parameter can be set to the following values: 1, 2.

Example

- ▶ SET /MEDIA/UART/P1.StopBits=1
- ◀ pw /MEDIA/UART/P1.StopBits=1
- ▶ CALL /MEDIA/UART/P1:applySettings(1)
- ◀ mO /MEDIA/UART/P1:applySettings

INFO: The **applySettings** method will save and apply the new value, and makes the extender reboot.

6.12.6. Setting the Parity

Command and Response

- ▶ SET•/MEDIA/UART/<port>.Parity=<parity_setting>
- ◀ pw•/MEDIA/UART/<port>.Parity=<parity_setting>

Parameters

Identifier	Parameter description	Parameter values
<parity_setting>	Parity (error detection method)	n : none o : odd e : even

Example

- ▶ SET /MEDIA/UART/P1.Parity=n
- ◀ pw /MEDIA/UART/P1.Parity=n
- ▶ CALL /MEDIA/UART/P1:applySettings(1)
- ◀ mO /MEDIA/UART/P1:applySettings

INFO: The **applySettings** method will save and apply the new value, and makes the extender reboot.

6.13. Arranging the Extenders to Groups

6.13.1. Querying the Working Mode (Unicast/Multicast)

Command and Response *#unicast #multicast*

- ▶ GET•/MANAGEMENT/MULTICAST.MulticastMode
- ◀ pw•/MANAGEMENT/MULTICAST.MulticastMode=<Multicast_mode>

Parameters

If the <Multicast_mode> parameter is **0** (or **false**), the device is in **Unicast mode**. If the property value is **1** (or **true**), the device is in **Multicast mode**.

Example

- ▶ GET /MANAGEMENT/MULTICAST.MulticastMode
- ◀ pw /MANAGEMENT/MULTICAST.MulticastMode=false

6.13.2. Setting the Working Mode (Unicast/Multicast)

Command and Response

- ▶ SET•/MANAGEMENT/MULTICAST.MulticastMode=<Multicast_mode>
- ◀ pw•/MANAGEMENT/MULTICAST.MulticastMode=<Multicast_mode>

Parameters

See the previous section.

Example

- ▶ SET /MANAGEMENT/MULTICAST.MulticastMode=1
- ◀ pw /MANAGEMENT/MULTICAST.MulticastMode=true
- ▶ CALL /MANAGEMENT/MULTICAST:applySettings(1)

ATTENTION! When you change the working mode, the **applySettings** method must be called always to store the new settings. After that, the device is restarted automatically; response is not sent.

6.13.3. Querying the Video Stream ID Setting Method

The Video stream ID can be set by the front panel DIP switch or by software.

Command and Response *#videostreamid #streamid*

- ▶ GET•/SYS/MB/PHY.ChannelIdSetBySoftware
- ◀ pr•/SYS/MB/PHY.ChannelIdSetBySoftware=<sw_setting>

Parameters

If the <sw_setting> parameter is **0** (or **false**), the Video Stream ID is set by the front panel DIP switch (HW setting). If the property value is **1** (or **true**), the Video Stream ID can be set by the command described in the [Setting the Video Stream ID](#) section (SW setting).

Example

- ▶ GET /SYS/MB/PHY.ChannelIdSetBySoftware
- ◀ pr /SYS/MB/PHY.ChannelIdSetBySoftware=false

Explanation

The current Video Stream ID is HW setting, the front panel DIP switch is valid. The ID can be changed only by the DIP switch.

ATTENTION! The state of the DIP switch can be ignored, see the [DIP Switch Enable](#) section.

6.13.4. Querying the DIP Switch Value

The current value of the DIP switch can be queried as follows:

Command and Response *#dipswitch*

- ▶ GET•/SYS/MB/GPIO.DipSwitch
- ◀ pr•/SYS/MB/GPIO.DipSwitch=<DIP_value>

Parameters

The states/values of the <DIP_value> parameter are described in the [DIP Switch States](#) section.

Example

- ▶ GET /SYS/MB/GPIO.DipSwitch
- ◀ pr /SYS/MB/GPIO.DipSwitch=0x8

Explanation

The current value is 0x8: the switch is in '1000' state, the Video Stream ID is '8'.

6.13.5. Querying the Video Stream ID

The response of the command below contains the current Video Stream ID, but contains no information about the setting method (HW setting/SW setting).

Command and Response

- ▶ GET•/SYS/MB/PHY.VideoChannelId
- ◀ pw•/SYS/MB/PHY.VideoChannelId=<channel_ID>

Parameter

The value of the <channel_ID> can be between 1 and 9999.

Example

- ▶ GET /SYS/MB/PHY.VideoChannelId
- ◀ pw /SYS/MB/PHY.VideoChannelId=10

6.13.6. DIP Switch Enable

The front panel DIP switch can be ignored with the command below. The command can be used to avoid an accidental Video stream ID change caused by a front panel switching.

Command and Response

- ▶ SET•/SYS/MB/GPIO.DipSwitchEnable=<switch_valid>
- ◀ pw•/SYS/MB/GPIO.DipSwitchEnable=<switch_valid>

Parameters

If the <switch_valid> parameter is **0** (or **false**), the DIP switch change has no effect on the Video Stream ID. If the property value is **1** (or **true**), the DIP switch has an effect on the ID (when it is in a state other than '0000').

Example

- ▶ SET /SYS/MB/GPIO.DipSwitchEnable=false
- ◀ pw /SYS/MB/GPIO.DipSwitchEnable=false

6.13.7. Setting the Video Stream ID

If the front panel DIP switch is in '0000' state or the DIP switch state is ignored, the Video Stream ID can be set by the following command:

Command and Response

- ▶ SET•/SYS/MB/PHY.VideoChannelId=<channel_ID>
- ◀ pw•/SYS/MB/PHY.VideoChannelId=<channel_ID>

Parameter

The value of the <channel_ID> can be between 1 and 9999.

Example

- ▶ SET /SYS/MB/PHY.VideoChannelId=8
- ◀ pw /SYS/MB/PHY.VideoChannelId=8

6.14. Video Wall Settings

Basic Rules *#videowall*

- One Decoder can be a part of only one video wall.
- The video wall must have a unique name within a system; the length of the name shall not exceed 24 characters.
- The video walls are stored in the LW3 protocol tree of the Decoders.
- All the Decoders and the Encoder must be set one-by-one. The set parameters are applied only in the given device.

Short Instructions

- Step 1.** All the affected VINX devices must be in Multicast mode. See the [Setting the Working Mode \(Unicast/Multicast\)](#) section to set the mode if necessary.
- Step 2.** Set the same Video Stream ID in the Encoder and in all desired Decoders. Use the front panel DIP switch and/or the commands as described in the [Setting the Video Stream ID](#) section.
- Step 3.** Send the Video Wall setup command to each Decoder one-by-one as described in the [Assigning a Decoder to a Video Wall](#) section.

6.14.1. Setting the Name of the Video Wall

Set the name of the video wall in the Decoder devices as follows:

Command and Response

- ▶ SET•/MEDIA/VIDEO/O1/VIDEOWALL.Name=<wall_name>
- ◀ pw•/MEDIA/VIDEO/O1/VIDEOWALL.Name=<wall_name>

Parameters

The video wall must have a unique name (<wall_name>) within a system ; the length of the name shall not exceed 24 characters.

Example

- ▶ SET /MEDIA/VIDEO/O1/VIDEOWALL.Name=Office_2x2
- ◀ pw /MEDIA/VIDEO/O1/VIDEOWALL.Name=Office_2x2

6.14.2. Assigning a Decoder to a Video Wall

ATTENTION! Setting the name of the video wall is highly recommended (see the previous section).

Command and Response

- ▶ SET•/MEDIA/VIDEO/O1/VIDEOWALL.Layout=<wall_parameters>
- ◀ pw•/MEDIA/VIDEO/O1/VIDEOWALL.Layout=<wall_parameters>

Parameters

The <wall_parameters> include the following order of settings:

<tot_col>;<tot_row>;<col_pos>;<row_pos>;<wid>;<hei>;<Hgap>;<Vgap>;<Btop>;<Bbot>;<Bléf>;<Bríg>;

Identifier	Parameter description
<tot_col>	Total number of columns
<tot_row>	Total number of rows
<col_pos>	Column position of the Decoder
<row_pos>	Row position of the Decoder
<wid>	The width of the screen (display area) (mm)
<hei>	The height of the screen (display area) (mm)
<Hgap>	Horizontal gap between the sinks (mm)
<Vgap>	Vertical gap between the sinks (mm)
<Btop>	Top bezel of the given sink (mm)
<Bbot>	Bottom bezel of the given sink (mm)
<Bléf>	Left bezel of the given sink (mm)
<Bríg>	Right bezel of the given sink (mm)

Example

- ▶ SET /MEDIA/VIDEO/O1/VIDEOWALL.Layout=2;2;1;1;520;320;0;0;0;0;0;0;
- ◀ pw /MEDIA/VIDEO/O1/VIDEOWALL.Layout=2;2;1;1;520;320;0;0;0;0;0;0;

Explanation

2x2 sized video wall is defined, the current Decoder is positioned in the first column, in the first row. The size of a display device is 520x320 mm. No bezel and gap are set.

INFO: If the Bezel and Gap values are zero, the dimensions (width and height) do not matter.

6.15. Setting up a Video Wall (Example)

The following list of commands show how a video wall can be created by sending LW3 commands. The specifications are the following:

- **Name:** Office_2x2
- **Size:** 2x2
- **Video Stream ID:** 10
- **IP address:** Encoder: 192.168.0.80, Decoders: see the figure
- **Display width:** 520x320 mm (each display)
- **Gap:** 20 mm
- **Bezel:** 10 mm (at all sides)

A1	B1
192.168.0.81	192.168.0.82
A2	B2
192.168.0.83	192.168.0.84

INFO: The IP address of each device has been set previously, and the DIP switch is in **0000** position.

Commands Sent to the Encoder

- ▶ SET /MANAGEMENT/MULTICAST.MulticastMode=true
- ◀ pw /MANAGEMENT/MULTICAST.MulticastMode=true
- ▶ SET /SYS/MB/PHY.VideoChannelId=10
- ◀ pw /SYS/MB/PHY.VideoChannelId=10

Commands Sent to the Decoder (A1)

- ▶ SET /MANAGEMENT/MULTICAST.MulticastMode=true
- ◀ pw /MANAGEMENT/MULTICAST.MulticastMode=true
- ▶ SET /SYS/MB/PHY.VideoChannelId=10
- ◀ pw /SYS/MB/PHY.VideoChannelId=10
- ▶ SET /MEDIA/VIDEO/O1/VIDEOWALL.Layout=2;2;1;1;520;320;20;20;0;10;0;10;
- ◀ pw /MEDIA/VIDEO/O1/VIDEOWALL.Layout=2;2;1;1;520;320;20;20;0;10;0;10;
- ▶ SET /MEDIA/VIDEO/O1/VIDEOWALL.Name=Office_2x2
- ◀ pw /MEDIA/VIDEO/O1/VIDEOWALL.Name=Office_2x2

Commands Sent to the Decoder (B1)

- ▶ SET /MANAGEMENT/MULTICAST.MulticastMode=true
- ◀ pw /MANAGEMENT/MULTICAST.MulticastMode=true
- ▶ SET /SYS/MB/PHY.VideoChannelId=10
- ◀ pw /SYS/MB/PHY.VideoChannelId=10
- ▶ SET /MEDIA/VIDEO/O1/VIDEOWALL.Layout=2;2;2;1;520;320;20;20;0;10;10;0;
- ◀ pw /MEDIA/VIDEO/O1/VIDEOWALL.Layout=2;2;2;1;520;320;20;20;0;10;10;0;
- ▶ SET /MEDIA/VIDEO/O1/VIDEOWALL.Name=Office_2x2
- ◀ pw /MEDIA/VIDEO/O1/VIDEOWALL.Name=Office_2x2

Commands Sent to the Decoder (A2)

- ▶ SET /MANAGEMENT/MULTICAST.MulticastMode=true
- ◀ pw /MANAGEMENT/MULTICAST.MulticastMode=true
- ▶ SET /SYS/MB/PHY.VideoChannelId=10
- ◀ pw /SYS/MB/PHY.VideoChannelId=10
- ▶ SET /MEDIA/VIDEO/O1/VIDEOWALL.Layout=2;2;1;2;520;320;20;20;10;0;0;10;
- ◀ pw /MEDIA/VIDEO/O1/VIDEOWALL.Layout=2;2;1;2;520;320;20;20;10;0;0;10;
- ▶ SET /MEDIA/VIDEO/O1/VIDEOWALL.Name=Office_2x2
- ◀ pw /MEDIA/VIDEO/O1/VIDEOWALL.Name=Office_2x2

Commands Sent to the Decoder (B2)

- ▶ SET /MANAGEMENT/MULTICAST.MulticastMode=true
- ◀ pw /MANAGEMENT/MULTICAST.MulticastMode=true
- ▶ SET /SYS/MB/PHY.VideoChannelId=10
- ◀ pw /SYS/MB/PHY.VideoChannelId=10
- ▶ SET /MEDIA/VIDEO/O1/VIDEOWALL.Layout=2;2;2;2;520;320;20;20;10;0;10;0;
- ◀ pw /MEDIA/VIDEO/O1/VIDEOWALL.Layout=2;2;2;2;520;320;20;20;10;0;10;0;
- ▶ SET /MEDIA/VIDEO/O1/VIDEOWALL.Name=Office_2x2
- ◀ pw /MEDIA/VIDEO/O1/VIDEOWALL.Name=Office_2x2

6.16. Crosspoint Switching Examples

The VINX devices can be arranged and used as a matrix. The working method of such a system is different from that of a dedicated matrix switcher. Therefore, the approach and the control commands are also different.

Important Notices about System Usage #switch #crosspoint

- The switching is realized in practice by **setting the Video stream ID** of the given **Decoder** to the same ID as the desired **Encoder**.
- The commands are addressed to **each Decoder separately** via LAN.
- The **crosspoint state cannot be queried** by a global command.
- **TX** means the **Encoder**, **RX** means the **Decoder** in the drawings.

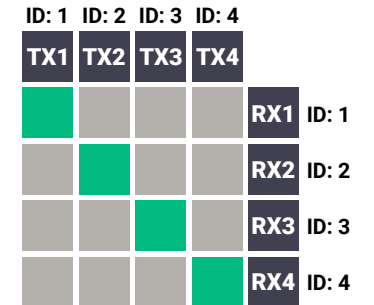

The following example demonstrates a 4x4 matrix layout and crosspoint-related commands, and how they can be used for crosspoint-handling. The initial state in the example is **diagonal**: I1-O1; I2-O2; I3-O3; I4-O4.

6.16.1. Switching an Input to an Output

- ▶ SET /SYS/MB/PHY.VideoChannelId=2
- ◀ pw /SYS/MB/PHY.VideoChannelId=2

The command above is sent to the **RX1 Decoder**.

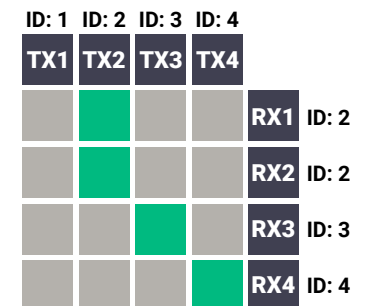
**6.16.2. Switching an Input to All Outputs**

- ▶ SET /SYS/MB/PHY.VideoChannelId=2
- ◀ pw /SYS/MB/PHY.VideoChannelId=2

The command above is sent to **all Decoders** separately.

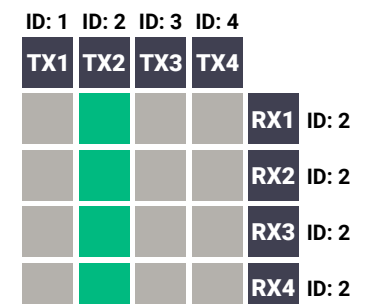
**6.16.3. Switching the Source of a Video Wall**

The source **Encoder** of an existing video wall (**VW1**) can be changed. In this case, the Video stream ID of the affected **Decoders** must be changed one-by-one.

- ▶ SET /SYS/MB/PHY.VideoChannelId=4
- ◀ pw /SYS/MB/PHY.VideoChannelId=4

The command above is sent to **all Decoders** in the **Video wall**.

INFO: The video wall properties are not changed by switching the **Encoder**. Each **Decoder** will show **the same area** of the (new) image as it had been set previously.

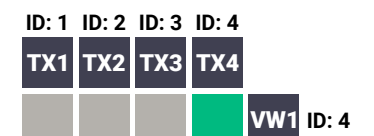

6.16.4. Multiple Switching

The commands have to be sent to the **Decoders** one-by-one, thus the switching is realized in practice by **setting the Video stream ID of the Decoders to the same ID as the desired Encoders**.

▶ `SET /SYS/MB/PHY.VideoChannelId=4`

◀ `pw /SYS/MB/PHY.VideoChannelId=4`

The command above is sent to **RX1**.

▶ `SET /SYS/MB/PHY.VideoChannelId=3`

◀ `pw /SYS/MB/PHY.VideoChannelId=3`

The command above is sent to **RX2**.

▶ `SET /SYS/MB/PHY.VideoChannelId=2`

◀ `pw /SYS/MB/PHY.VideoChannelId=2`

The command above is sent to **RX3**.

▶ `SET /SYS/MB/PHY.VideoChannelId=1`

◀ `pw /SYS/MB/PHY.VideoChannelId=1`

The command above is sent to **RX4**.

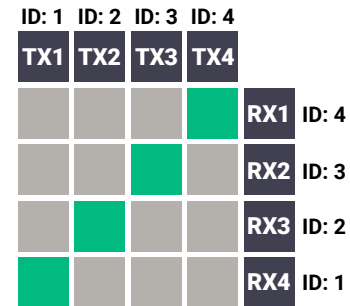

6.17. EDID Management (Encoder)

The Advanced EDID Management is available also by sending LW3 protocol commands. The structure of the EDID memory can be found in the [The EDID Memory Structure](#) section.

6.17.1. Querying the Emulated EDID

Command and Response *#edid*

▶ `GET•/EDID.EdidStatus`

◀ `pr•/EDID.EdidStatus=<EDID_mem_loc>:E1`

Parameters

Identifier	Parameter description	Parameter values
<EDID_mem_loc>	The EDID memory location	F1-F132: Factory preset EDIDs U1-U5: User presets D1: The EDID of the Display Device at the local output

E1 means the Emulated EDID memory location (Input port).

INFO: There are empty slots in the Factory EDID range for future developments. See the [Factory EDID List](#) section.

Example

▶ `GET /EDID.EdidStatus`

◀ `pr /EDID.EdidStatus=F47:E1`

Explanation

F47 EDID (Factory #47) is currently emulated on the input port of the Encoder (E1).

6.17.2. Setting the Emulated EDID on the Input Port

Command and Response

▶ `CALL•/EDID:switch(<source>:<destination>)`

◀ `mO•/EDID:switch`

Parameters

Identifier	Parameter description	Parameter values
<source>	Source EDID memory location	F1-F132: Factory preset EDIDs U1-U5: User presets D1: The EDID of the Display Device at the local output
<destination>	The emulated EDID memory of the input port	E1

Example

▶ `CALL /EDID:switch(F49:E2)`

◀ `mO /EDID:switch`

6.17.3. Copying an EDID

Command and Response

- ▶ CALL•/EDID:copy(<source>:<destination>)
- ◀ mO•/EDID:copy

Parameters

Identifier	Parameter description	Parameter values
<source>	Source EDID memory location	F1-F132: Factory preset EDIDs U1-U5: User presets D1: The EDID of the Display Device at the local output
<destination>	The desired User EDID location	U1-U5

Example

- ▶ CALL /EDID:copy(D1:U1)
- ◀ mO /EDID:copy

Explanation

The EDID of the last connected sink (HDMI output, D1) has been copied to U1 User memory slot.

6.17.4. Querying the Preferred Resolution of an EDID

Command and Response

- ▶ GET•/EDID/<EDID_mem>/<EDID_mem_loc>.PreferredResolution
- ◀ pr•/EDID/<EDID_mem>/<EDID_mem_loc>.PreferredResolution=<Resolution>

Parameters

Identifier	Parameter description	Parameter values
<EDID_mem>	The desired EDID memory type	F: Factory preset EDIDs U: User presets D: EDID from a connected display device E: Emulated EDID
<EDID_mem_loc>	The desired EDID memory location	F1-F132: Factory preset EDIDs U1-U5: User presets D1: The EDID of the Display Device at the local output E1: The emulated EDID at the input
<Resolution>	The preferred resolution in the indicated format	<width>x<height><scan_mode><refresh_rate>Hz <scan_mode>: p (progressive), i (interlaced)

Example

- ▶ GET /EDID/U/U2.PreferredResolution
- ◀ pr /EDID/U/U2.PreferredResolution=1920x1080p60.00Hz

INFO: Use the **Manufacturer** property to query the manufacturer, and the **MonitorName** property to query the name of the monitor.

6.17.5. Deleting an EDID from the User Memory

Command and Response

- ▶ CALL•/EDID:delete(<User_loc>)
- ◀ mO•/EDID:delete

Parameters

Identifier	Parameter description	Parameter values
<User_loc>	User EDID location	U1-U5

Example

- ▶ CALL /EDID:delete(U1)
- ◀ mO /EDID:delete

6.18. LW3 Commands - Quick Summary

System Commands

Querying the Product Name

- ▶ GET•/.ProductName

Setting the Device Label

- ▶ SET•/SYS/MB.DeviceLabel=<Custom_name>

Querying the Serial Number

- ▶ GET•/.SerialNumber

Querying the Package Version

- ▶ GET•/SYS/MB.PackageVersion

Resetting the Device

- ▶ CALL•/SYS:reset()

Restoring the Factory Default Settings

- ▶ CALL•/SYS:factoryDefaults()

Cleartext Login Protection

Setting the Login Password

- ▶ CALL•/LOGIN:setPassword(<password>)

Logging into the Device

- ▶ CALL•/LOGIN:login(<password>)

Logging out of the Device

- ▶ CALL•/LOGIN:logout(<password>)

Enabling/Disabling the Cleartext Login Function

- ▶ SET•/LOGIN:LoginEnable=<login_state>

Network Configuration

Querying the IP Address

- ▶ GET•/MANAGEMENT/NETWORK.IpAddress

Querying the IP Setup Mode (FW 2.x.x)

- ▶ GET•/MANAGEMENT/NETWORK.IpSetupMode

Setting the IP Setup Mode (FW 2.x.x)

- ▶ SET•/MANAGEMENT/NETWORK.IpSetupMode

Querying the DHCP State (FW 1.x.x)

- ▶ GET•/MANAGEMENT/NETWORK.DhcpEnabled

Setting the DHCP State (FW 1.x.x)

- ▶ SET•/MANAGEMENT/NETWORK.DhcpEnabled=<DHCP_state>

Setting a Static IP Address

- ▶ SET•/MANAGEMENT/NETWORK.StaticIpAddress=<IP_address>

Querying the Subnet Mask

- ▶ GET•/MANAGEMENT/NETWORK.NetworkMask

Setting a Static Subnet Mask

- ▶ SET•/MANAGEMENT/NETWORK.StaticNetworkMask=<subnet_mask>

Querying the Gateway Address

- ▶ GET•/MANAGEMENT/NETWORK.GatewayAddress

Setting a Static Gateway Address

- ▶ SET•/MANAGEMENT/NETWORK.StaticGatewayAddress=<gateway_address>

Encoder-related Commands

Querying the Input Video Signal Presence

- ▶ GET•/MEDIA/VIDEO/<in>.SignalPresent

Querying the Resolution of the Input Video Signal

- ▶ GET•/MEDIA/VIDEO/<in>.Resolution

Querying the Active Input Port

- ▶ GET•/MEDIA/VIDEO.InputSource

Querying the Video Input Selection Mode

- ▶ GET•/MEDIA/VIDEO.SelectionMode

Setting the Video Input Selection Mode

- ▶ SET•/MEDIA/VIDEO.SelectionMode=<sel_mode>

Querying the Video Quality Mode

- ▶ GET•/MEDIA/VIDEO/QUALITY.QualityMode

Setting the Video Quality Mode

- ▶ SET•/MEDIA/VIDEO/QUALITY.QualityMode=<quality_mode>

Querying the HDCP State

- ▶ GET•/MEDIA/VIDEO/<in>.HdcpState

Setting the HDCP State

- ▶ SET•/MEDIA/VIDEO/<in>.HdcpEnable=<HDCP_state>

Force HDCP Version

- ▶ SET•/MEDIA/VIDEO/<out>.ForceHDCP=<hdcp_version>

Decoder-related Commands**Querying the Resolution of the Output Video Signal**

- ▶ GET•/MEDIA/VIDEO/<out>.Resolution

Querying the Scaling Mode of the Output Video Signal

- ▶ GET•/MEDIA/VIDEO/<out>/SCALER.ScalingMode

Setting the Scaling Mode of the Output Video Signal

- ▶ SET•/MEDIA/VIDEO/<out>/SCALER.ScalingMode=<sc_mode>

Querying the Signal Type of the Output Video Signal

- ▶ GET•/MEDIA/VIDEO/<out>/SCALER.SignalType

Setting the Resolution of the Output Video Signal

- ▶ SET•/MEDIA/VIDEO/<out>/SCALER.OutputResolution

Rotating the screen

- ▶ SET•/MEDIA/VIDEO/<out>/VIDEOWALL.Rotation=<value>

Setting the No-signal-screen

- ▶ SET•/MEDIA/VIDEO/<out>.EnableVinxGui=<vinx_gui>

Setting the State of the Output

- ▶ SET•/MEDIA/VIDEO/<out>.OutputEnabled=<output_state>

Setting the Delay of Muting the Audio During Switching

- ▶ SET•/SYS/MB/PHY.AudioMuteDelay=<delay_time>

Setting the Switch Order

- ▶ SET•/SYS/MB/PHY.SwitchOrder=<order>

Using of Free Routing

- ▶ SET•/MANAGEMENT/MULTICAST/FreeRoute=<freeroute_state>
- ▶ SET•/MANAGEMENT/MULTICAST/FreeRouteMap=<freeroute_value>

Custom Logo Management**Querying the Storage Size**

- ▶ GET•/MANAGEMENT/CUSTOMLOGO.StorageSize=

Querying the Free Storage Size

- ▶ GET•/MANAGEMENT/CUSTOMLOGO/StorageFreeSize=

Querying the Number of Uploaded Files

- ▶ GET•/MANAGEMENT/CUSTOMLOGO.FileCount=

Querying the List of Uploaded Files

- ▶ GET•/MANAGEMENT/CUSTOMLOGO.FileList=

Deleting a Custom Image

- ▶ CALL•/MANAGEMENT/CUSTOMLOGO>DeleteFile(<file_name>)

Selecting a Custom Logo - No Connection to the Encoder

- ▶ SET•/MEDIA/VIDEO/<out>.NoConnectionLogo=<file_name>

Selecting a Custom Logo - No Active Video Signal

- ▶ SET•/MEDIA/VIDEO/<out>.NoVideoLogo=<file_name>

Selecting a Custom Logo to Be Forced Over the Active Video

- ▶ CALL•/MEDIA/VIDEO/<out>.forceShowCustomLogo=(<file_name>)

Setting the Status of the Information Text

- ▶ SET•/MEDIA/VIDEO/<out>.ShowInfoText=<switch_valid>

Setting the Signal Type of the Output Video Signal

- ▶ SET•/MEDIA/VIDEO/<out>/SCALER.SignalType=<sig_type>

Querying the State of the USB Connection

- ▶ GET•/MEDIA/KM.Controlling

Establishing the USB Connection

- ▶ CALL•/MEDIA/KM:acquireControl(true)

Audio-related Commands**Querying the Audio Input Selection Mode**

- ▶ GET•/MEDIA/AUDIO.ioSelect

Setting the Audio Input Selection Mode

- ▶ SET•/MEDIA/AUDIO.ioSelect=<sel_mode>

Querying the Audio Signal Presence

- ▶ GET•/MEDIA/AUDIO/<in>.SignalPresent

Analog Audio Input/Output Signal Level Settings**Querying the Volume (Exact Value)**

- ▶ GET•/MEDIA/AUDIO/<port>.AnalogVolumedB

Setting the Volume (Exact Value)

- ▶ SET•/MEDIA/AUDIO/<port>.AnalogVolumedB=<value>

Setting the Volume (by a Step Value)

- ▶ CALL•/MEDIA/AUDIO/<port>.stepVolumeDb(<value>)

Querying the Volume (in Percentage)

- ▶ GET•/MEDIA/AUDIO/<port>.AnalogVolume

Setting the Volume (in Percentage)

- ▶ SET•/MEDIA/AUDIO/<port>.AnalogVolume=<value>

Setting the Volume (by a Step Value in Percentage)

- ▶ `CALL•/MEDIA/AUDIO/<port>:stepVolumePercent(<value>)`

Querying the Mute State

- ▶ `GET•/MEDIA/AUDIO/<port>.AnalogMute`

Setting the Mute State

- ▶ `GET•/MEDIA/AUDIO/<port>.AnalogMute`

Serial Port Settings**Setting the Port Availability**

- ▶ `SET•/MEDIA/UART/<port>.Enabled=<port_status>`

Setting the Baud Rate of the Port

- ▶ `SET•/MEDIA/UART/<port>.Baudrate=<Baud_value>`

Setting the RS-232 Port Mode

- ▶ `SET•/MEDIA/UART/<port>.Guest=<port_mode>`

Setting the Data Bits

- ▶ `SET•/MEDIA/UART/<port>.DataBits=<Databits_value>`

Setting the Stop Bits

- ▶ `SET•/MEDIA/UART/<port>.StopBits=<Stopbits_value>`

Setting the Parity

- ▶ `SET•/MEDIA/UART/<port>.Parity=<parity_setting>`

Arranging the Extenders to Groups**Querying the Working Mode (Unicast/Multicast)**

- ▶ `GET•/MANAGEMENT/MULTICAST.MulticastMode`

Setting the Working Mode (Unicast/Multicast)

- ▶ `SET•/MANAGEMENT/MULTICAST.MulticastMode=<Multicast_mode>`

Querying the Video Stream ID Setting Method

- ▶ `GET•/SYS/MB/PHY.ChannelIdSetBySoftware`

Querying the DIP Switch Value

- ▶ `GET•/SYS/MB/GPIO.DipSwitch`

Querying the Video Stream ID

- ▶ `GET•/SYS/MB/PHY.VideoChannelId`

DIP Switch Enable

- ▶ `SET•/SYS/MB/GPIO.DipSwitchEnable=<switch_valid>`

Setting the Video Stream ID

- ▶ `SET•/SYS/MB/PHY.VideoChannelId=<channel_ID>`

Video Wall Settings**Setting the Name of the Video Wall**

- ▶ `SET•/MEDIA/VIDEO/O1/VIDEOWALL.Name=<wall_name>`

Assigning a Decoder to a Video Wall

- ▶ `SET•/MEDIA/VIDEO/O1/VIDEOWALL.Layout=<wall_parameters>`

EDID Management (Encoder)**Querying the Emulated EDID**

- ▶ `GET•/EDID.EdidStatus`

Setting the Emulated EDID on the Input Port

- ▶ `CALL•/EDID:switch(<source>:<destination>)`

Copying an EDID

- ▶ `CALL•/EDID:copy(<source>:<destination>)`

Querying the Preferred Resolution of an EDID

- ▶ `GET•/EDID/<EDID_mem>/<EDID_mem_loc>.PreferredResolution`

Deleting an EDID from the User Memory

- ▶ `CALL•/EDID:delete(<User_loc>)`

7

Firmware Update

The devices can be updated via the built-in web page, or by the Lightware Device Updater v2 (LDU2) software. The software is available at www.lightware.com. In order to get the firmware pack with the necessary components (*.lfp or *.lfp2 file) for your specific product, please contact support@lightware.com.

- ▶ [BUILT-IN WEB OR LDU2](#)
- ▶ [IMPORTANT NOTICES – BEFORE STARTING THE UPDATE](#)
- ▶ [ABOUT THE FIRMWARE PACKAGE \(LFP/LFP2 FILE\)](#)
- ▶ [OPTION 1. – UPDATING VIA THE BUILT-IN WEB PAGE](#)
- ▶ [OPTION 2. – UPDATING BY LDU2](#)
- ▶ [RUNNING THE SOFTWARE](#)
- ▶ [THE UPDATING STEPS](#)
- ▶ [COMMAND LINE INTERFACE \(CLI\)](#)
- ▶ [CLI COMMANDS](#)
- ▶ [IF THE UPDATE IS NOT SUCCESSFUL](#)

7.1. Built-in Web or LDU2

The firmware of the VINX device can be updated via two ways. The following table contains the features of the methods:

Function	Built-in Web	LDU2
Platform	Mozilla Firefox, Google Chrome	Windows, mac OS
Installation	Web browser needed only	Required
LFP file support	✓	-
LFP2 file support	✓	✓
Log export	-	✓

7.2. Important Notices – Before Starting the Update

- **Update all VINX devices** within a system. Make sure that the same firmware runs on the devices. If the firmwares are different, the seamless operation is not guaranteed.
- While the firmware is being updated, **signal processing is not performed**. The normal operation mode is suspended, as the device is switched to bootload mode.
- **Do not interrupt** the firmware update. If any problem occurs, reboot the device and restart the process.
- The settings and parameters (e.g. User EDID memory, video wall settings) **will not be lost** by updating the firmware.

7.3. About the Firmware Package (LFP/LFP2 File)

The firmware files are packed in an LFP/LFP2 package. You need only this file to do the update in your device.

- The package contains all the necessary components, binary, and other files; You do not have to get further files.
- There is a descriptor file in the package that contains each firmware with version number, and a list showing the compatible devices, which is displayed in Lightware Device Updater v2 (LDU2) after loading.

7.4. Option 1. – Updating via the Built-in Web Page

WARNING! Never disconnect the power source from the VINX devices during the update! Interrupting the firmware update may cause the device to become unusable.

This method is available by the built-in web page of the VINX device. We recommend this way of update if you do not have the chance to install a software, or you have just a few devices.

7.4.1. Firmware Updating Steps

- Step 1.** Get the necessary **firmware pack (*.lfp or *.lfp2 file)** and save it to the control device (computer/mobile device).
- Step 2.** **Establish the connection** from the computer/mobile device to the desired VINX extender as described in the [Connecting via the Built-in Web Page](#).
- Step 3.** Navigate to the **Advanced Settings** tab.
- Step 4.** Locate the **Update Firmware** section and press the **Choose file** button. Browse the firmware package file and press **OK**.

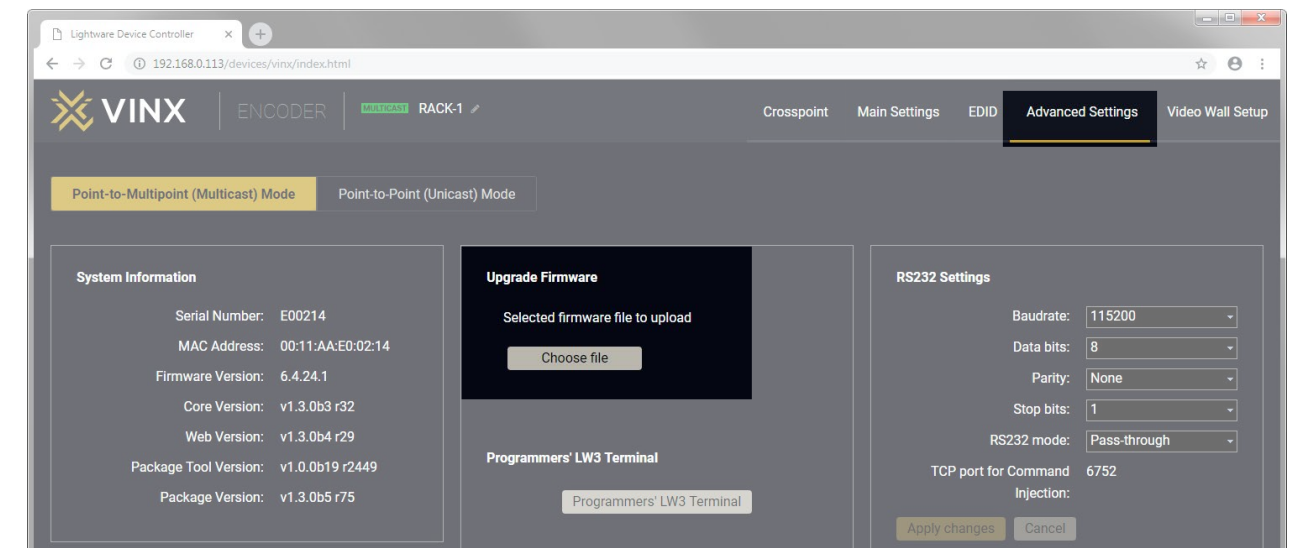

Firmware Update via the Built-in Web Page

- Step 5.** Press the **Update Firmware** button. The firmware pack will be uploaded into the device, and the update process is started automatically.
- Step 6.** The progress bar and a short label will show the current state of the process.

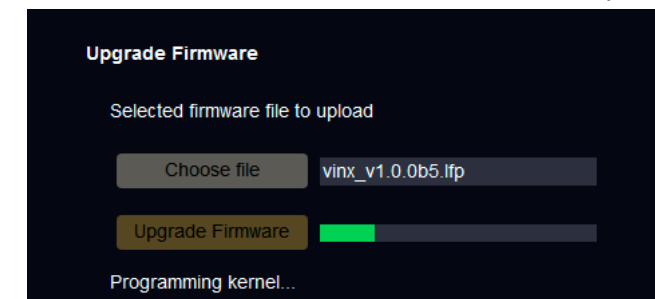

- Step 7.** When the programming is finished, the device will reboot and the connection will be lost. Powering the device off and on again is recommended.

INFO: LFP and LFP2 packages are also accepted for updating via the built-in web.

7.5. Option 2. – Updating by LDU2

7.5.1. Introduction

Lightware Device Updater v2 (LDU2) software is the second generation of the LFP-based (Lightware Firmware Package) firmware update process.

DIFFERENCE: The software can be used for uploading the packages with LFP2 extension only. LDU2 is not suitable for using LFP files, please use the LDU software for that firmware update.



7.5.2. Preparation

Most Lightware devices can be controlled over several interfaces (e.g. Ethernet, USB, RS-232). But the firmware can usually be updated over one dedicated interface, which is the Ethernet in most cases.

If you want to update the firmware of one or more devices, you need the following:

- **LFP2 file,**
- **LDU2 software** installed on your PC or Mac.

Both can be downloaded from www.lightware.com/downloads.

Optionally, you can download the **release notes** file in HTML format.

7.5.3. About the Firmware Package (LFP2 File)

All necessary tools and binary files are packed into the LFP2 package file. You need only this file to do the update on your device.

- This allows the use of the same LFP2 package for different devices.
- The package contains all the necessary components, binary, and other files.
- The release notes is included in the LFP2 file, which is displayed in the window where you select the firmware package file in LDU2.

7.5.4. LDU2 Installation

ATTENTION! Minimum system requirement: 2 GB RAM. The minimum display resolution is 1600x900.

INFO: The Windows and the Mac applications have the same look and functionality.

Download the software from www.lightware.com/downloads.

Installation in case of Windows OS

Run the installer. If the User Account Control displays a pop-up message, click **Yes**.

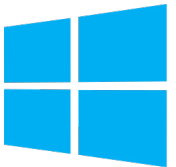

Installation Modes

Normal install	Snapshot install
Available for Windows, MacOS and Linux	Available for Windows
The installer can update only this instance	Cannot be updated
One updateable instance may exist for all users	Many different versions can be installed for all users

ATTENTION! Using the default Normal install is highly recommended.

INFO: If you have a previously installed version, you will be prompted to remove the old version before installing the new one.

Installation in case of macOS

Mount the DMG file by double clicking on it, and drag the LDU2 icon over the Applications icon to copy the program into the Applications folder. If you want to copy LDU2 into another location, just drag the icon over the desired folder.

ATTENTION! Please check the firewall settings on the macOS device. LDC needs to be added to the exceptions of the blocked softwares for the proper operation.

INFO: This type of installer is equal with the **Normal install** of Windows.



Installation in case of Linux

Step 1. Download the **archive file** (tar.gz) from www.lightware.com and unpack it to a temp folder.

Step 2. Run the **install_ldu2.sh** file in the temp folder. The script will install LDU2 into the following folder: HOME/.local/share/lightware/ldu2.

Step 3. The folder above will contain this file: **LightwareDeviceUpdaterV2.sh**, which can be used to start LDU2.

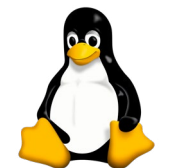

7.6. Running the Software

You have two options:

- **Starting the LDU2** by double-clicking on the shortcut/program file, or
- Double-clicking on an **LFP2 file**.

LDU2 Auto-Update

At startup, the software checks if a newer version is available on the web.

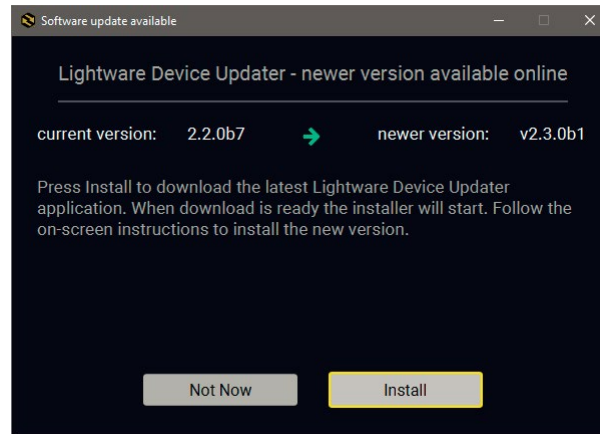

Main Screen

When the software is started by the shortcut, the device discovery screen appears. Press the **Discover devices** button to start finding the Lightware devices:

DISCOVER DEVICES

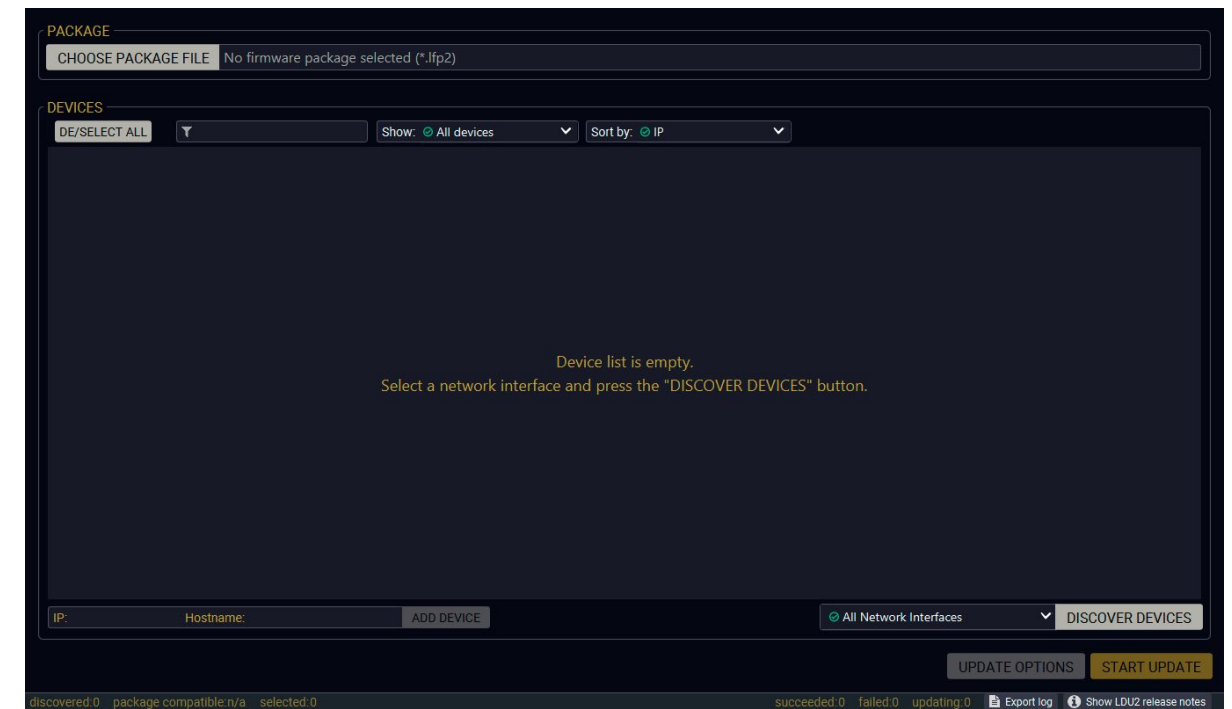

Devices may also be added manually by typing the IP address in the box near the bottom of the screen. From LDU2 version v2.16.1, manual addition of devices can also be done using the hostname.

ATTENTION! If the device cannot be added by the hostname, please use the IP address.

If you start the software by double-clicking on the LFP2 file, the firmware will be loaded. Press the **Discover devices** button; all the devices will be listed that are compatible with the selected firmware pack.







INFO: If you press the **Select package file** button, the release notes of the LFP2 file will be displayed in the right panel; see the [Step 1. Select the Firmware Package.](#) section.

Device List

When the discovery has completed, the devices available on the network are listed in the application.

ID	Device Name	IP	S/N	Package	FW	HW
1.	UMX-TPS-TX140K UMX-TPS-TX140K	192.168.0.100	00006363			
2.	VINX-120AP-HDMI-ENC-DNT ENC-0011AAE0C071	192.168.1.9	E0C071	v2.0.1b3	v2.0.1b1	
3.	VINX-110-HDMI-DEC DEC-0011AAE80015	192.168.1.13	E80015	v2.0.1b3	v2.0.1b1	
4.	RAP-B511-EU-K LW_RAP-B511-EU-K_34567890	192.168.1.14	34567890	v1.1.0b3	v1.2.0b2	N/A
5.	MMX4x2-HT200 LW_MMX4x2-HT200_00005031	192.168.1.15	00005031	v1.6.0b19	v1.6.0b19	V12_AAA0

Legend of the Icons

-  **IP address editor** The IP address of the device can be changed in the pop-up window.
-  **Identify me** Clicking on the icon results the front panel LEDs blinking for 10 seconds, which helps identify the device physically.
-  **Favorite device** The device has been marked, thus the IP address is stored. When a device is connected with that IP address, the star will be highlighted in that line.
-  **Further information available** Device is unreachable. Change the IP address using the front panel LCD menu or the IP address editor of the LDU2.
-  **Cleartext login enabled** The password-protection is enabled. You have to enter the password to perform the firmware update in the **Update options** window, or in the appearing window in the beginning of the update.
-  **Service mode** The device is in bootload mode. Backup and restore cannot be performed in this case.

7.7. The Updating Steps

ATTENTION! While the firmware is being updated, the normal operation mode is suspended, as the device is switched to bootload mode. Signal processing is not performed. Do not interrupt the firmware update. If any problem occurs, reboot the unit and restart the process.

Keeping the Configuration Settings

By default, device configuration settings are restored when the firmware update is finished. If factory reset has been chosen in the parameters window, all device settings will be erased. In the case of factory reset, you can save the settings of the device in the Lightware Device Controller software and restore it later.

The following flow chart demonstrates how this function works in the background.

Step 1. Create a backup

The current configuration of the device is being saved into a configuration backup file on your computer.

Step 2. Start the Update

The device reboots and starts in bootload mode (firmware update mode).

Step 3. Update

The CPU firmware is changed to the new one.

Step 4. Factory reset

All configuration settings are restored to the factory default values.

Step 5. Conversion / Restore

The firmware package checks the backup data before the restoration procedure, and if it is necessary, a conversion is applied to avoid incompatibility problems between the firmware versions. All configuration settings are restored to the device after the conversion.

If the factory default option is selected in the Parameters window, the conversion / restoration procedure will not be performed!

Step 6. Finish

Once the firmware update procedure is finished, the device reboots and is ready to use.

Step 1. Select the Firmware Package.

Press the **Choose Package File** button, and navigate to the location where the LFP2 file was saved. When you click on the name of package, the preview of the release notes are displayed in the right panel.

CHOOSE PACKAGE FILE

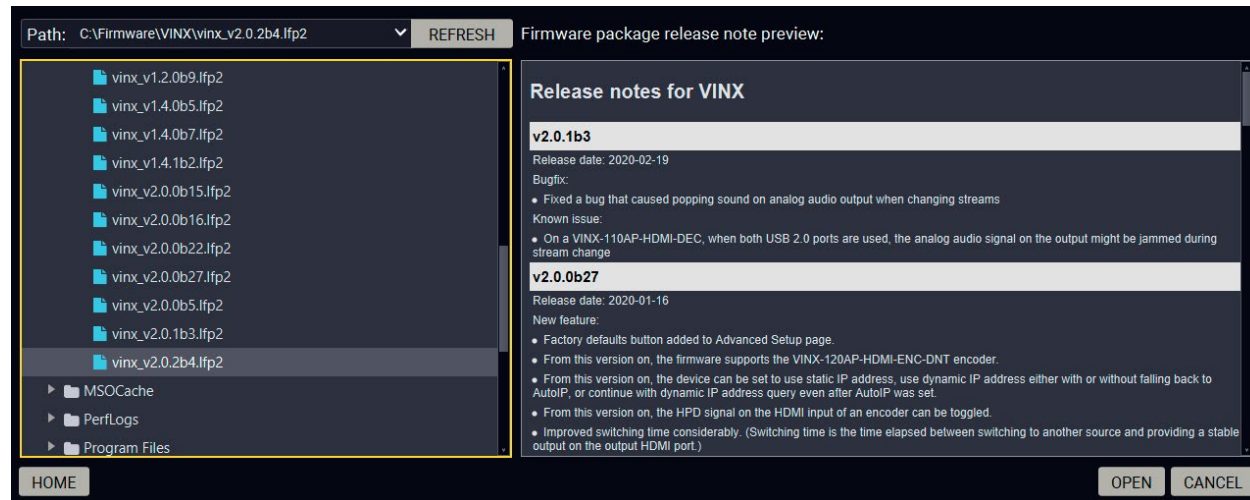

After the package file is loaded, the list is filtered to show the compatible devices only. The current firmware version of the device is highlighted in orange if it is different from the version of the package loaded.

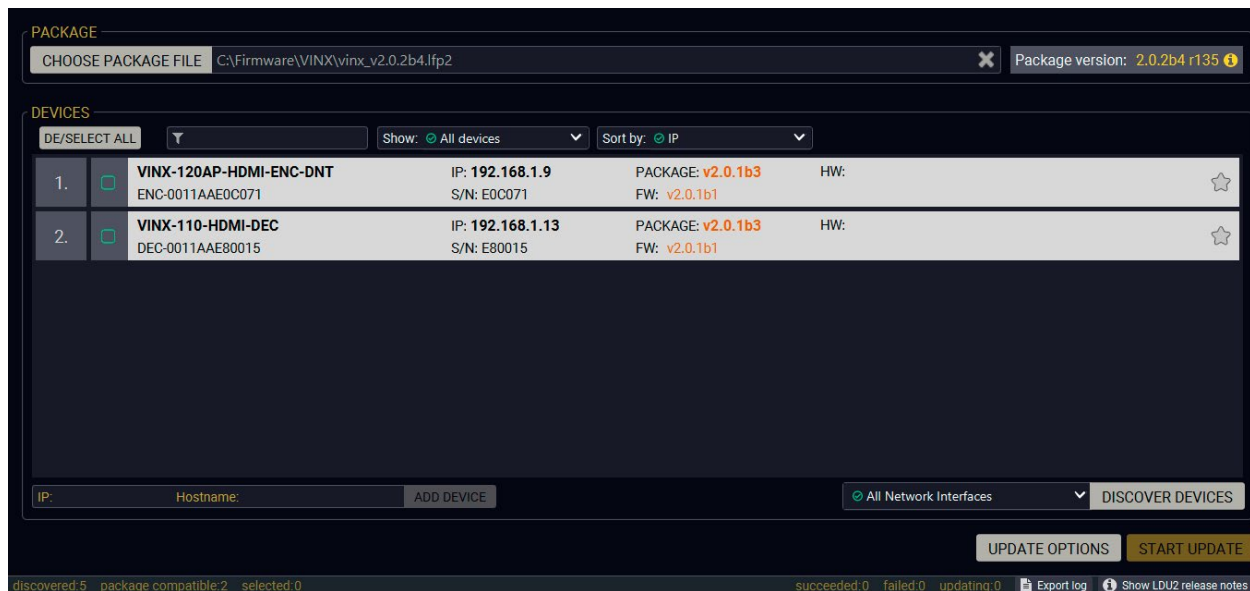

INFO: If you start the update by double-clicking on the LFP file, the screen above will be loaded right away.

Step 2. Select the desired devices for updating.

Select the devices for updating; the selected line will be highlighted in green.

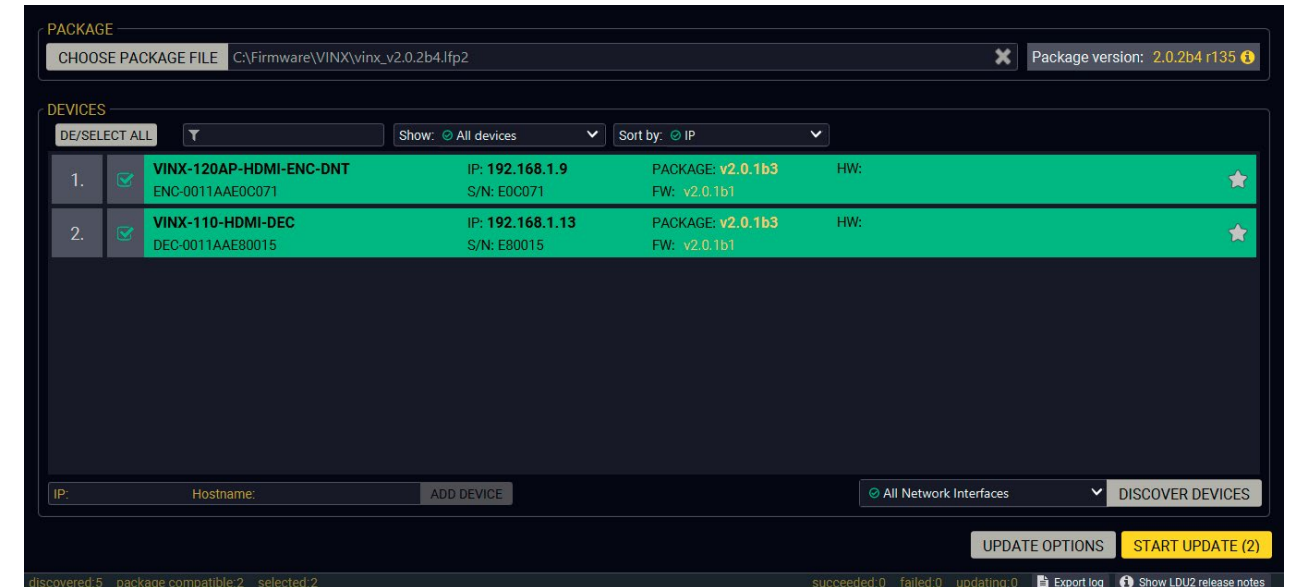
**Step 3. Check the update parameters.**

DIFFERENCE: The appearing settings are device-dependent and can be different from device to device.

Clicking on the **Parameters** button, special settings will be available, like:

PARAMETERS

- Creating a backup about the configuration,
- Restoring the configuration or reloading the factory default settings after the firmware update,
- Uploading the default Miniweb (if available)
- Enter the password for the Cleartext login. `#builtinweb` `#miniweb` `#web`

INFO: The password entered here will be used for all selected devices where the Cleartext login is enabled. If the password is incorrect, a window will appear to ask for the correct one for each device during the update.

Please arrange the settings carefully.

Step 4. Start the update and wait until it is finished.

Click on the **Start Update** button to start the procedure. The status is shown in percent in the right side of the device line, and the overall process in the bottom progress bar.



INFO: The device might reboot during the firmware update procedure.

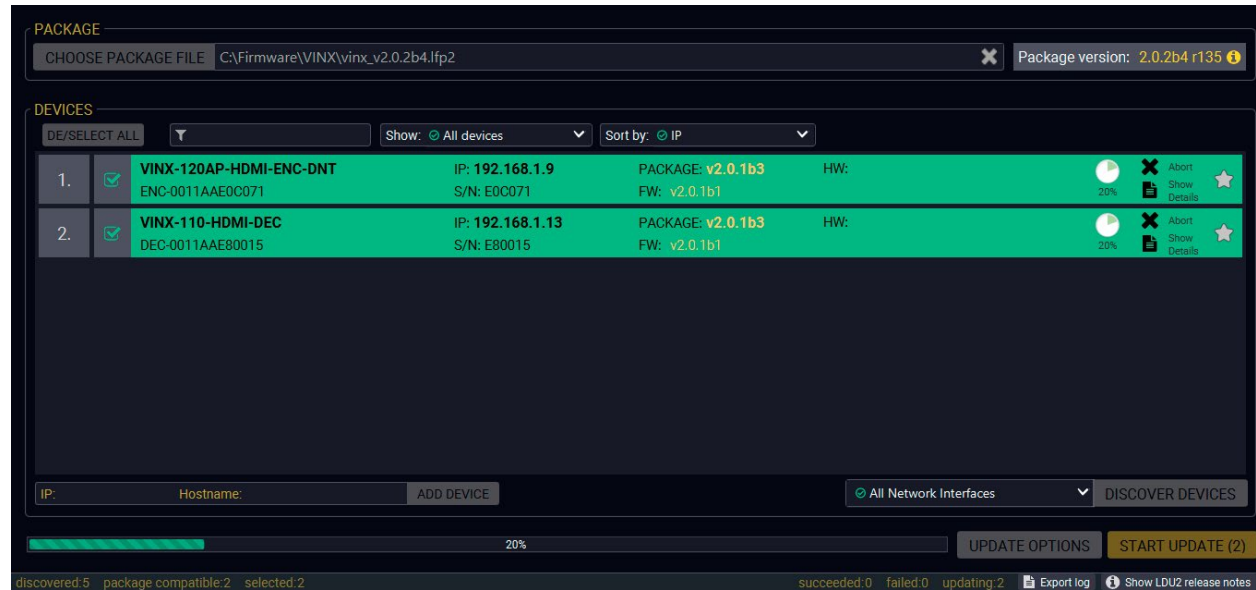

When the progress bar reaches 100% (**Done** is displayed at all devices), the update of all devices are finished successfully and a message appears; you can close the software.

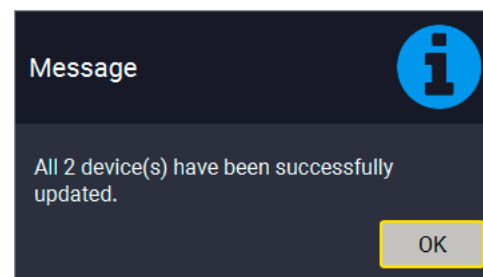
**Step 5. Wait until the unit reboots with the new firmware.**

Once the firmware update procedure is completed, the device is rebooted with the new firmware. Shutting down and restarting the device is recommended.

7.8. Command Line Interface (CLI)

DIFFERENCE: The Command Line Interface is available from LDU2 v2.9.0b9.

The CLI of the LDU2 software is a simple tool for creating scriptable device updates without the need for human interactions. It allows batch updating with the same features that are available in the case of GUI usage.

7.8.1. How to Run**Running under Windows® OS**

The installer of LDU2 puts the following file into the installation folder:

LightwareDeviceUpdaterV2_CLI.cmd

CLI is available via this file, the exe is not suitable for that purpose. Open a command line window to execute or test the features directly.

Step 1. Open an Explorer window where the cmd file is located, the default is:

c:\Program Files (x86)\Lightware\Lightware Device Updater V2\LightwareDeviceUpdaterV2_CLI.cmd.

Step 2. Click on the address line (highlighted in blue in the picture), type **cmd.exe** and press enter. The command interpreter window of Windows is opened at the path of the LDU2 install folder.

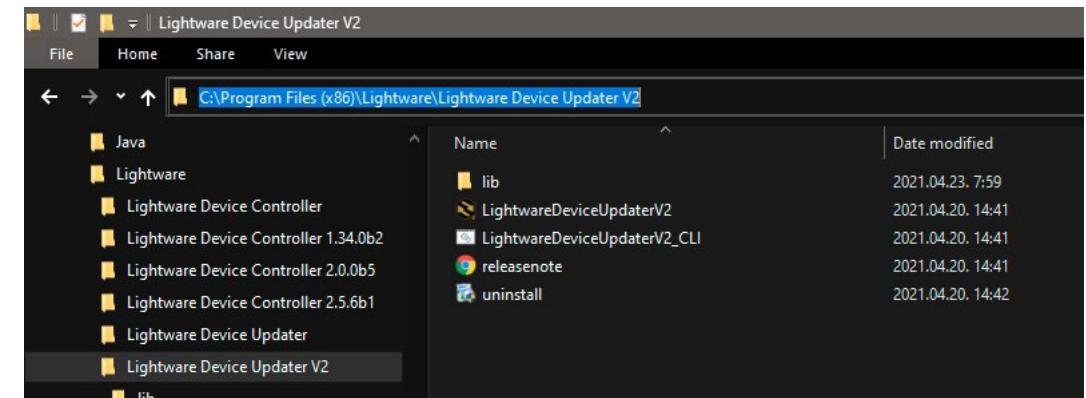

Step 3. Now you can use the **LightwareDeviceUpdaterV2_CLI.cmd** file with the commands and options that are described in the coming sections:

Running under Linux

The Command Line Interface under Linux Operating Systems can be run by the following:

LightwareDeviceUpdaterV2.sh.

Running an update:

```
bash LightwareDeviceUpdaterV2.sh update --ip 172.24.5.27 --package ~/Downloads/vinx_v3.1.0b4.lfp2
```

The commands and options are the same under Windows® and Linux, too. The following sections contain examples with **LightwareDeviceUpdaterV2_CLI.cmd**.

7.8.2. How to Use

Command Structure

The commands can be run over CLI in the following way:

LightwareDeviceUpdaterV2_CLI.cmd [command] [options]

[Command]: a certain command described in the coming sections; only one command can be run at a time

[Options]: mandatory and/or optional parameters of the command, if any. Optional parameters have a default value, which can be found at each affected command. You only have to define the parameter if you want to apply a different value. The **order of the options** is arbitrary.

Important Notes

- CLI is **case-sensitive** (including commands, options and other parameters).
- There is **no limit** regarding the number of the devices to update. At most 20 devices are updated simultaneously, when one of them is finished, the following (21st) will be started automatically.
- If an update is failed, the IP address of the affected device(s) are listed at the end.

7.9. CLI Commands

INFO: The commands and options described in the following sections are the same under Windows® and Linux, too. The examples contain **LightwareDeviceUpdaterV2_CLI.cmd**.

About the Examples

- Sent command is in **blue**, response is in **grey**.
- If the response in practice is **longer than listed** in the example, this symbol can be seen: [...].

7.9.1. Help

The defined commands and options can be listed by the **help** command.

Command

LightwareDeviceUpdaterV2_CLI.cmd help

Example

```
C:\Program Files (x86)\Lightware\Lightware Device Updater V2>LightwareDeviceUpdaterV2_CLI.cmd help

C:\Program Files (x86)\Lightware\Lightware Device Updater V2>lib\jre\bin\java.exe -jar lib\ldu2.jar help
Command line usage:
  Win: LightwareDeviceUpdaterV2_CLI.cmd [command] [options]
  Linux: LightwareDeviceUpdaterV2.sh [command] [options]

Commands:
  * help
  * version
  * update
  * deviceInfo
  * restore
  * packageOptions

[...]
```

7.9.2. LDU2 Version

The response shows the version of the LDU2 and the version of the Script API (the Application Programming Interface that is used by the LDU2 and the script).

Command

LightwareDeviceUpdaterV2_CLI.cmd version

Example

```
C:\Program Files (x86)\Lightware\Lightware Device Updater V2>LightwareDeviceUpdaterV2_CLI.cmd version

C:\Program Files (x86)\Lightware\Lightware Device Updater V2>lib\jre\bin\java.exe -jar lib\ldu2.jar version
LDU2 version: 2.14.0b5
Script API version: 1.3.13
```

7.9.3. Check For New LDU2 Version

The following command can be used to check if an update of LDU2 is available. This is just a request, since the CLI is not suitable for handling the complete installation of the software.

Command

LightwareDeviceUpdaterV2_CLI.cmd checkForUpdates

Example 1

```
C:\Program Files (x86)\Lightware\Lightware Device Updater V2>LightwareDeviceUpdaterV2_CLI.cmd checkForUpdates

C:\Program Files (x86)\Lightware\Lightware Device Updater V2>lib\jre\bin\java.exe -jar lib\ldu2.jar checkForUpdates
Current LDU2 version: 2.14.0b5
LDU2 is up-to-date
```

Example 2

```
c:\Program Files (x86)\Lightware\Lightware Device Updater V2>LightwareDeviceUpdaterV2_CLI.cmd checkForUpdates

c:\Program Files (x86)\Lightware\Lightware Device Updater V2>lib\jre\bin\java.exe -jar lib\ldu2.jar checkForUpdates
Current LDU2 version: 2.13.1b4
New version is available online: v2.14.0b5
Download URL: http://update.lightware.hu/ldu2/1wr/v2.14.0b5/install_LDU2_v2.14.0b5.exe
```

7.9.4. Device Info

The most important information about the selected device is displayed; see the example for more details.

Command

```
LightwareDeviceUpdaterV2_CLI.cmd deviceInfo [options]
```

Options

Option	Description	Required?
-i or --ip	List of IP addresses of devices to be updated	one of them is mandatory
-n or --hostName	List of host names of devices to be updated	
-v or --packageVersion	Shows installed package version only	optional

Example 1

```
C:\Program Files (x86)\Lightware\Lightware Device Updater V2>LightwareDeviceUpdaterV2_CLI.cmd deviceInfo --ip
192.168.0.110
C:\Program Files (x86)\Lightware\Lightware Device Updater V2>lib\jre\bin\java.exe -jar lib\ldu2.jar deviceInfo --ip
192.168.0.110
Product name: WP-VINX-110P-HDMI-ENC
IP address: 192.168.0.110
Serial number: 808139
MAC address: 34:1B:22:80:81:39
Part number: 91810012
Device label: VINX-TX-808139
Package version: v3.0.1b8
CPU FW version: v3.0.1b3
HW version:
Operation mode: Application mode
```

Example 2

```
C:\Program Files (x86)\Lightware\Lightware Device Updater V2>LightwareDeviceUpdaterV2_CLI.cmd deviceInfo --ip
192.168.0.110 --packageVersion
C:\Program Files (x86)\Lightware\Lightware Device Updater V2>lib\jre\bin\java.exe -jar lib\ldu2.jar deviceInfo --ip
192.168.0.110 --packageVersion
v3.0.1b8
```

7.9.5. Update

This command can be used to update the firmware of the devices.

Command

```
LightwareDeviceUpdaterV2_CLI.cmd update [options]
```

Options

Option	Description	Required?
-p or --package	The path of the firmware package file	yes
-i or --ip	List of IP addresses of devices to be updated	one of them is mandatory
-n or --hostName	List of host names of devices to be updated	
-r or --reportProgress	Report update progress in percentage form. Default: false	optional

Example

```
C:\Program Files (x86)\Lightware\Lightware Device Updater V2>LightwareDeviceUpdaterV2_CLI.cmd update --ip
192.168.1.7 --package C:\Firmwares\UMX-HDMI-140_v1.3.0b5.lfp2 --reportProgress

C:\Program Files (x86)\Lightware\Lightware Device Updater V2>lib\jre\bin\java.exe -jar lib\ldu2.jar update --ip
192.168.0.110 --package C:\Firmwares\vinx_v3.1.0b4.lfp2 --reportProgress
[2022-03-24 14:48:17.267] [ INFO] [          main] - Device IPs: [192.168.0.110]
[2022-03-24 14:48:19.400] [ INFO] [          main] - All selected devices are available over the network.
[2022-03-24 14:48:19.779] [ INFO] [          main] - All the selected devices are compatible with the specified
package.
[2022-03-24 14:48:20.004] [ INFO] [ 192.168.0.110] - Version of the package: 3.1.0
[2022-03-24 14:48:20.293] [ INFO] [ 192.168.0.110] -
  >>> Device IP:      192.168.0.110
  >>> Product name:  WP-VINX-110P-HDMI-ENC
  >>> Part number:   91810012
  >>> Serial number: 808139
  >>> Device label:  VINX-TX-808139
  >>> Mac address:   34:1B:22:80:81:39
  >>> Core FW version: v3.1.0b3 r2
  >>> Package version: v3.1.0b4 r1
[2022-03-24 14:48:20.352] [ INFO] [ 192.168.0.110] - Uploading vinx.zip at: http://192.168.0.110/cgi-bin/astfwup.
cgi
[2022-03-24 14:48:24.788] [ INFO] [ProgressReporter] - Progress: 6%
[2022-03-24 14:48:29.796] [ INFO] [ProgressReporter] - Progress: 10%
[2022-03-24 14:48:34.802] [ INFO] [ProgressReporter] - Progress: 12%
[2022-03-24 14:48:39.811] [ INFO] [ProgressReporter] - Progress: 14%
[2022-03-24 14:48:44.814] [ INFO] [ProgressReporter] - Progress: 16%
[2022-03-24 14:49:32.323] [ INFO] [ 192.168.0.110] - The device is starting to update itself...
[2022-03-24 14:49:37.476] [ INFO] [ 192.168.0.110] - Polling update_fw_result.txt...
[2022-03-24 14:54:29.924] [ INFO] [ProgressReporter] - Progress: 27%
[2022-03-24 14:54:54.932] [ INFO] [ProgressReporter] - Progress: 28%
[2022-03-24 14:55:29.946] [ INFO] [ProgressReporter] - Progress: 29%
[2022-03-24 14:55:54.949] [ INFO] [ProgressReporter] - Progress: 30%
[2022-03-24 14:56:24.952] [ INFO] [ProgressReporter] - Progress: 31%
[2022-03-24 14:56:49.955] [ INFO] [ProgressReporter] - Progress: 32%
[2022-03-24 14:57:19.957] [ INFO] [ProgressReporter] - Progress: 33%
[2022-03-24 14:57:49.961] [ INFO] [ProgressReporter] - Progress: 34%
[2022-03-24 14:58:09.633] [ INFO] [ 192.168.0.110] - Self-update process is DONE
[2022-03-24 14:58:09.964] [ INFO] [ProgressReporter] - Progress: 85%
[2022-03-24 14:58:29.095] [ INFO] [ 192.168.0.110] - Rebooting...
[2022-03-24 14:58:29.099] [ INFO] [ 192.168.0.110] - Trying to reconnect after device reset over LW3. #1.0
[2022-03-24 14:58:29.973] [ INFO] [ProgressReporter] - Progress: 90%
[2022-03-24 14:58:43.294] [ INFO] [ 192.168.0.110] - Trying to reconnect after device reset over LW3. #2.0
[2022-03-24 14:58:57.524] [ INFO] [ 192.168.0.110] - Trying to reconnect after device reset over LW3. #3.0
[2022-03-24 14:59:11.756] [ INFO] [ 192.168.0.110] - Trying to reconnect after device reset over LW3. #4.0
[2022-03-24 14:59:25.963] [ INFO] [ 192.168.0.110] - Trying to reconnect after device reset over LW3. #5.0
[2022-03-24 14:59:40.179] [ INFO] [ 192.168.0.110] - Trying to reconnect after device reset over LW3. #6.0
[2022-03-24 14:59:40.222] [ INFO] [ 192.168.0.110] - Reconnected to device. Device uptime: 72.0
[2022-03-24 14:59:40.268] [ INFO] [ 192.168.0.110] - Package version on device is verified.
[2022-03-24 14:59:40.268] [ INFO] [ 192.168.0.110] - Device update complete!
[2022-03-24 14:59:40.269] [ INFO] [ 192.168.0.110] - Done

All 1 update(s) finished successfully.
```

The lines containing "ProgressReporter" can be enabled optionally. If it is enabled, the current state is displayed for every step in the update procedure..

7.9.6. Exit Codes

There is a return value in all cases when a command run is finished. Currently, three codes are defined:

Code	Displayed text	Description
0	N/A	The update performed successfully
1	Update error (ErrorCode:1)	The error happened during the update
2	CLI error (ErrorCode:2)	The error happened before starting the update

The error line contains further information about the error.

Querying the Exit Code under Windows®

```
c:\Program Files (x86)\Lightware\Lightware Device Updater V2\echo %errorlevel%
0
```

Querying the Exit Code under Linux

```
echo $?
0
```

If this value is queried after the update and it is 0, the update was performed successfully.

7.10. If the Update is not successful





- Restart the process and try the update again.
- If the device cannot be switched to bootload (firmware update) mode, you can do that manually as written in the User's manual of the device. Please note that backup and restore cannot be performed in this case.
- If the backup cannot be created for some reason, you will get a message to continue the process without backup or stop the update. A root cause can be that the desired device is already in bootload (firmware update) mode, thus the normal operation mode is suspended and backup cannot be made.
- If an update is not successful, the **Export log** button becomes red. If you press the button, you can download the log file as a ZIP package, which can be sent to Lightware Support if needed. The log files contain useful information about the circumstances to find the root cause. *#bootload*

8

Troubleshooting

Usually, if the system seems not to transport the signal as expected, the best strategy for troubleshooting is to check signal integrity through the whole signal chain starting from source side and moving forward to receiver end.

Pictogram Legend











-  Link to the section of connections/cabling.
-  Link to the section of front panel operation.
-  Link to the section of the built-in web page.
-  Link to the section of LW3 protocol commands.

The following sections are available in the chapter:

- ▶ [USE CASES](#)
- ▶ [HOW TO SPEED UP THE TROUBLESHOOTING PROCESS](#)

8.1. Use Cases

At first, check front panel LEDs and take the necessary steps according to their states. For more information about front and rear panel LEDs of the devices, refer to the [VINX-120-HDMI-ENC](#) and [VINX-110-HDMI-DEC](#) sections.

Symptom	Root cause	Action	Refer to
Video issues			
No video on the screen	No video signal on the input.	Check the source and the cable connections.	
	The Video Stream IDs are different.	Check the settings of the extenders and assign them.	 5.4.1
	HDCP is disabled (EDID information cannot be read)	Enable the HDCP on the input of the Encoder. (In certain cases, the source device cannot read the EDID from the Encoder.)	 5.4.3
	HDCP-encrypted content sent to a non-HDCP sink.	Replace the sink to a HDCP-capable one.	
Network issues			
Cannot connect to an extender	The extenders did not get IP address.	The Ethernet switch needs more time to be ready than the extenders. Reboot the VINX devices.	
	The extender is not connected.	Check the LEDs and the cable connections.	 2.1 2.2
	The extenders and the PC are not in the same subnet.	Make sure the devices are located in the same subnet.	
USB issues			
The video stream cannot be changed by the keyboard shortcut	The keyboard is connected to an USB 2.0 port.	Connect the keyboard to the USB 1.1 port.	
	Shortcut is not assigned properly.	Check the settings and set the shortcut(s) again.	 5.4.1
	The keyboard is connected to another Decoder.	Connect it to the desired Decoder.	
USB data transmission does not work	Another Decoder is selected for USB transmission.	Check the LEDs or the USB settings in the built in web page.	 2.2  5.8.2
	The Encoder and the computer are not connected over USB.	Connect the supplied USB cable between the computer and the Encoder.	

8.2. How to Speed Up the Troubleshooting Process

Lightware's technical support team is always working hard to provide the fastest support possible. Our team's response time is one of the best in the industry, and in the toughest of cases we can directly consult with the hardware or software engineer who designed the product to get the information from the most reliable source.

However, the troubleshooting process can be even faster... with your help.

There are certain pieces of information that push us in the right direction to find the root cause of the problem. If we receive most of this information in the first e-mail, or it is gathered at the time when you call us, then there is a pretty high chance that we will be able to respond with the final solution right away. This information is the following:

- Schematic (a pdf version is preferred, but a hand drawing is sufficient).
- Serial number(s) of the device(s) (it is either printed somewhere on the box or you can query it in the Device Controller software or on the built-in website).
- Firmware versions of the devices (please note that there may be multiple CPUs or controllers in the device and we need to know all of their firmware versions, a screenshot is the best option).
- Cable lengths and types (in our experience, it's usually the cable).
- Patch panels, gender changers or anything else in the signal path that can affect the transmission.
- Signal type (resolution, refresh rate, color space, deep color).
- Emulated EDID(s) (please save them as a file and send it to us).
- Actions to take in order to re-create the problem (if we cannot reproduce the problem, it is hard for us to find the cause).
- Photo or video about the problem ('image noise' can mean many different things, it's better if we see it too).
- Error logs from the Device Controller software.
- In the case of Event Manager issue, the event file and/or backup file from the Device Controller software.
- The more of the information above you can give us, the better. Please send this information to the Lightware Support Team (support@lightware.com) to speed up the troubleshooting process.

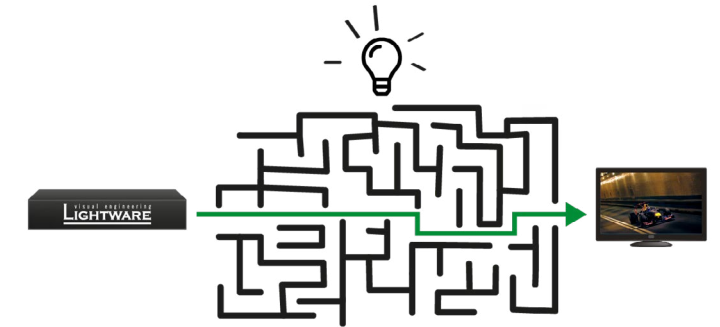

9

Technologies

The following sections contain descriptions and useful technical information on how the devices work in the background. The content is based on experiences and cases we met in the practice. These sections help to understand features and technical standards like the following:

- ▶ [EDID MANAGEMENT](#)
- ▶ [AV OVER IP](#)
- ▶ [HDCP MANAGEMENT](#)
- ▶ [RS-232 SIGNAL MANAGEMENT \(VINX AP-SERIES\)](#)

9.1. EDID Management

9.1.1. Understanding the EDID

The Extended Display Identification Data (EDID) is the passport of display devices (monitors, TV sets, projectors). It contains information about the capabilities of the display, such as supported resolutions, refresh rates (these are called Detailed Timings), the type and manufacturer of the display device, etc.

After connecting a source to a display (DVI, HDMI, DP), the source reads out the EDID to determine the resolution and refresh rate of the image to be transmitted.

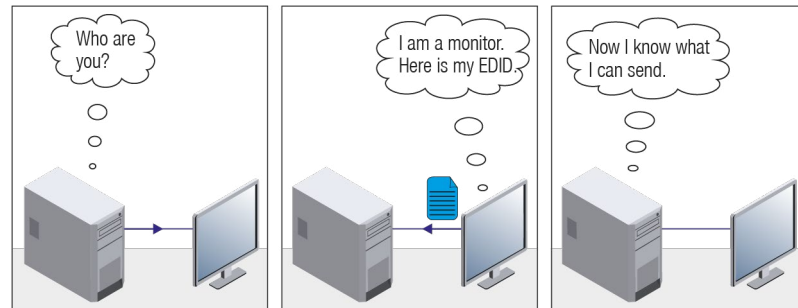

EDID Communication

Most DVI computer displays have a 128-byte-long EDID structure. However, Digital Televisions and HDMI capable displays may have another 128 bytes, which is called E-EDID and defined by CEA (Consumer Electronics Association). This extension contains information about additional Detailed Timings, audio capabilities, speaker allocation and HDMI capabilities. It is important to know that all HDMI capable devices must have CEA extension, but not all devices with CEA extension are HDMI capable.

Common Problems Related to EDID

- Problem:** “My system consists of the following: a computer, a Lightware device, a WUXGA (1920x1200) LCD monitor, and an SXGA (1280x1024) projector. I would like to see the same image on the monitor and the projector. What EDID should I choose on the Lightware device?”
- Solution:** If you want to see the image on both displays, you need to select the resolution of the smaller display (in this case SXGA), otherwise the smaller display may not show the higher resolution image.
- Problem:** “I have changed to a different EDID on an input port of the Lightware device to have a different resolution, but nothing happens.”
- Solution:** Some graphics cards and video sources read out the EDID only after power-up, and later they do not sense that the EDID has been changed. You need to restart your source to make it read out the EDID again.

9.1.2. Advanced EDID Management

Each DVI sink (e.g. monitors, projectors, plasma displays, etc...) must support the EDID data structure. Source BIOS and operating systems are likely to query the sink using DDC2B protocol to determine what pixel formats and interface are supported. DVI standard uses EDID data structure to identify the monitor type and capabilities. Most DVI sources (VGA cards, set top boxes, etc.) will output DVI signal after accepting the connected sink's EDID information. In the case of EDID readout failure or missing EDID, the source will not output DVI video signal.

Lightware devices provide the Advanced EDID Management function that helps system integration. The built-in EDID Router can store and emulate factory pre-programmed- and User programmable EDIDs. The EDID of the attached monitors or projectors for each output are stored in a non-volatile memory. This way, the EDID of a monitor is available when the monitor is unplugged or switched off.

Any EDID can be emulated on any input. An emulated EDID can be copied from the EDID router's memory (static EDID emulation), or from the last attached monitor's memory (dynamic EDID emulation). For example, the Lightware device can be set up to emulate a sink device, which is connected to one of the outputs. In this case, the EDID automatically changes if the monitor is replaced with another display device (as long as it has a valid EDID).

The EDID is independently programmable for all inputs without affecting each other. All inputs have their own EDID circuit.

INFO: The user is not required to disconnect the video cable to change an EDID as opposed to other manufacturer's products. The EDID can be changed even if a source is connected to the input and powered ON.

INFO: When the EDID has been changed, the router toggles the HOTPLUG signal for 2 seconds. Some sources do not sense this signal. In such cases, the source device must be restarted or powered OFF and ON again.

9.2. AV Over IP

Basics

Beside the traditional AV matrix switchers and extenders, the video over IP or networked AV system is the biggest leading technology in the AV industry. The spreading of the technology speeds up the general increasing of the use of the IT-related devices and equipment all around the world - from the offices to the homes.

The main difference compared to the traditional AV technologies is the method of the signal transmission: the networked AV transmitter/encoder devices convert the video signal to TCP/IP packets and transfer them to the receivers/decoders. The interface of the transmission can be CATx or fiber optical cable, depending on the signal bandwidth and the distance between the source and sink devices.

What is TCP/IP?

DEFINITION: TCP/IP, or the Transmission Control Protocol/Internet Protocol, is a suite of communication protocols used to interconnect network devices on the Internet or in a private network.

TCP/IP specifies how data is exchanged over the network by providing end-to-end communications that identify how it should be broken into packets, addressed, transmitted, routed and received at the destination. TCP/IP requires little central management, and it is designed to make networks reliable, with the ability to recover automatically from the failure of any device on the network. *

The two main protocols in the Internet protocol suite serve specific functions. TCP defines how applications can create channels of communication across a network. It also manages how a message is assembled into smaller packets before they are then transmitted over the Internet and reassembled in the right order at the destination address. *

IP defines how to address and route each packet to make sure it reaches the right destination. Each gateway computer on the network checks this IP address to determine where to forward the message. *

* Source: <https://searchnetworking.techtarget.com/definition/TCP-IP>

9.3. HDCP Management

Lightware Visual Engineering is a legal HDCP adopter. Several functions have been developed, which helps to solve HDCP related problems. Complex AV systems often have both HDCP and non-HDCP components. The matrix allows transmitting HDCP encrypted and unencrypted signals. The devices will be still HDCP compliant, as they will never output an encrypted signal to a non-HDCP compliant display device. If an encrypted signal is switched to a non-compliant output, a red screen alert or muted screen will appear.

9.3.1. Protected and Unprotected Content

Many video sources send HDCP protected signal if they detect that the sink is HDCP capable – even if the content is not copyrighted. This can cause trouble if an HDCP capable device is connected between the source and the display. In this case, the content cannot be viewed on non-HDCP capable displays and interfaces like event controllers. Rental and staging technicians often complain about certain laptops, which are always sending HDCP encrypted signals if the receiver device (display, matrix router, etc.) reports HDCP compliancy. Even though HDCP encryption is not required all the time (e.g. computer desktop image), certain laptops still do that.

To avoid unnecessary HDCP encryption, Lightware introduced the HDCP enabling/disabling function: the HDCP capability can be disabled in the Lightware device. If HDCP is disabled, the connected source will detect that the sink is not HDCP capable, and turn off authentication.

9.3.2. Disable Unnecessary Encryption

HDCP Compliant Sink

All the devices are HDCP-compliant, no manual setting is required, both protected and unprotected contents are transmitted and displayed on the sink.



Not HDCP-compliant Sink 1.

Not-HDCP compliant sink is connected to the matrix. Some sources (e.g. computers) always send HDCP encrypted signals if the receiver device reports HDCP compliancy, however, HDCP encryption is not required all the time (e.g. computer desktop image). If HDCP is enabled in the matrix, the image will not be displayed on the sink.



Setting the HDCP parameter to Auto on the output port and disable HDCP on the input port, the transmitted signal will not be encrypted if the content is not protected. Thus, non-HDCP compliant sinks will display non-encrypted signal.

Not HDCP-compliant Sink 2.

The layout is the same as in the previous case: non-HDCP compliant display device is connected to the matrix but the source would send protected content with encryption. If HDCP is enabled on the input port of the matrix, the source will send encrypted signal.



The sink is not HDCP compliant, thus it will not display the video signal, but blank screen is shown. If HDCP is disabled on the input port of the matrix, the source will not send the signal. The solution is to replace the display device with an HDCP-capable one.

9.3.3. HDCP v2.2

HDCP v2.2 is the latest evolution of copy protection. It is designed to create a secure connection between a source and a display. The 2.x version of HDCP is not a continuation of HDCPv1, and is rather a completely different link protection. One of the main differences is the number of the allowed devices within a closed A/V system: HDCP v2.2 allows 32 devices (HDCP v1.4 allows 128 devices). A further limit is that up to four level is allowed, which means the protected signal can be transmitted over at most four repeater/matrix/switcher devices. HDCP content protection is activated only if an active video stream is transmitted from the source to the display. The encryption is not activated without a video signal.

HDCP v2.2 standard allows the application of a previous version of HDCP (e.g. HDCP v1.4) between the source and the display if the source device allows it. According to the standard, if the image content is protected with HDCP, the highest supported content protection level has to be applied. However, if the highest level of protection is not justified by the source content, the level may be decreased to avoid compatibility problems; this case is determined by the source.

HDCP v2.2 Source and HDCP v1.4 Sink

In this case the signal of an HDCP v2.2 compliant source is switched to an HDCP v1.4 compliant sink device. The signal is encrypted with HDCP v2.2 on the input and encrypted with HDCP v1.4 on the output of the Lightware device. A lower level of encryption may be applied only if the source device/content allows it - according to the HDCP standard. In this case, the HDCP setting on the input port has to be set to HDCP 1.4 and Depends on input on the output port.



HDCP v1.4 Source and HDCP v2.2 Sink

The example below is the reversal of the previous case. An HDCP v1.4 compliant source sends a signal with HDCP v1.4 encryption. The signal is switched to an HDCP v2.2 compliant sink device. In this case, the outgoing signal has to be encrypted with the highest supported encryption level towards the sink, as the Lightware device and the sink are both HDCP v2.2 compliant. The HDCP v2.2 standard does not allow keeping the original HDCP v1.4 encryption level on the output.



What Kind of Signal Will be on the Output of the Lightware Device?

See the table below that summarizes the possible cases:

Incoming Signal	HDCP v1.4 Compatible Sink on the Output	HDCP v2.2. Compatible Sink on the Output
HDCP v1.4	HDCP v1.4	HDCP v2.2
HDCP v2.2 (convertable)*	HDCP v1.4	HDCP v2.2
HDCP v2.2 (not convertable)*	Red screen	HDCP v2.2

* Stream type 0: the video stream allows the conversion of the signal to apply a lower level of encryption.

** Stream type 1: the video stream does not allow the conversion of the signal.

9.4. RS-232 Signal Management (VINX AP-Series)

9.4.1. General Information

There are two types of devices in general serial communication:

- **Data Terminal Equipment:** Data Terminal Equipment (DTE) is an end instrument that converts user information into signals or reconverts received signals. Typical DTE devices: computers, LCD touch panels and control systems.
- **Data Circuit-terminating Equipment:** Data Circuit-terminating Equipment (DCE) is a device that sits between the DTE and a data transmission circuit. It is also called data communication equipment and data carrier equipment. Typical DCE devices: projectors, industrial monitors and amplifiers.

Among others, the pin assignment is different between DTE and DCE.

	DTE	DCE
Pin 2:	RD	TD
Pin 3:	TD	RD



RD: Received Data (digital input)
TD: Transmitted Data (digital output)

Different type of serial cables must be used between different serial devices.

	DTE	DCE
DTE	Null-modem	TD
DCE	Straight	Null-modem*

* In general, contact DCE with DCE by tail-circuit serial cable.

9.4.2. Types of Serial Cables

Straight Serial Cable	Null-modem Serial Cable
Straight pin-outs both ends.	Straight pin-out at the one end and cross pin-out at the other end (interchange lines of TX and RX).
	

Devices may have male or female plugs and their type can be straight or null-modem cables.

ATTENTION! The cable type does not depend on the plug type.

9.4.3. Serial Device Types

The types of VINX devices from serial data transmission point of view are the following:

VINX model	Unit type
VINX-120AP-HDMI-ENC, VINX-120AP-HDMI-ENC-DNT, VINX-210AP-HDMI-ENC	DCE
VINX-110AP-HDMI-DEC	DTE

9.4.4. RS-232 Signal Transmission over VINX Devices

The following examples show when source and sink devices are connected over Lightware's DCE- and DTE-type extenders for serial data transmission.

Data Transmission from a DCE Source to a DCE Sink Device

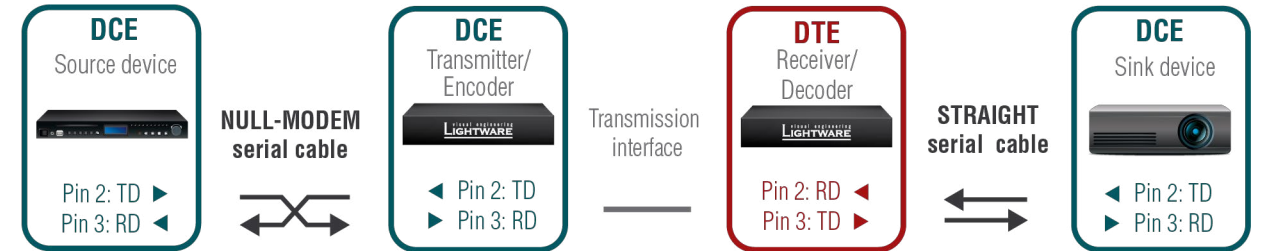

Data Transmission from a DCE Source to a DTE Sink Device

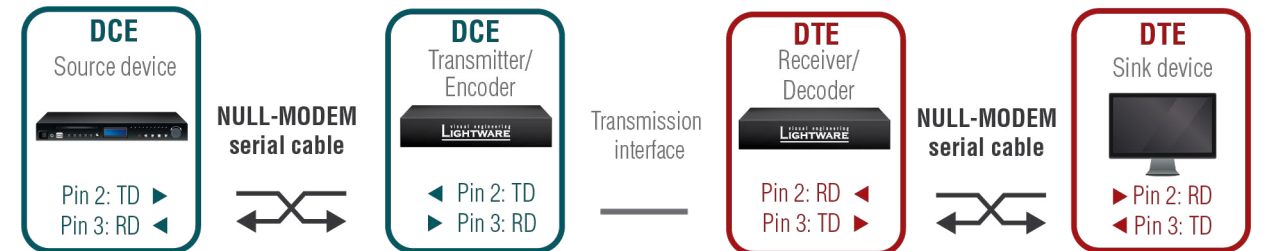

Data Transmission from a DTE Source to a DCE Sink Device

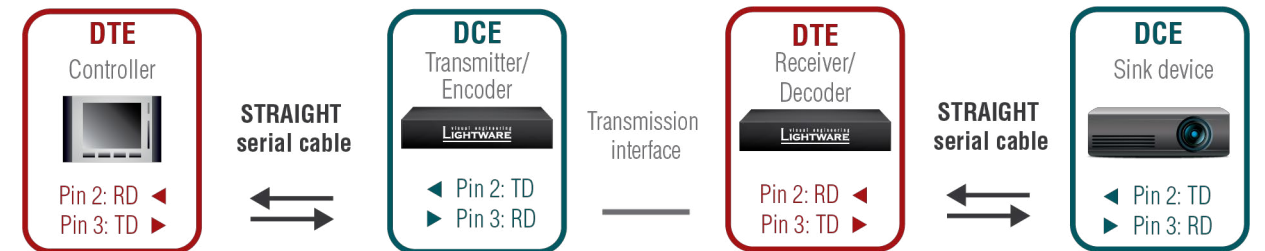

Data Transmission from a DTE Source to a DTE Sink Device

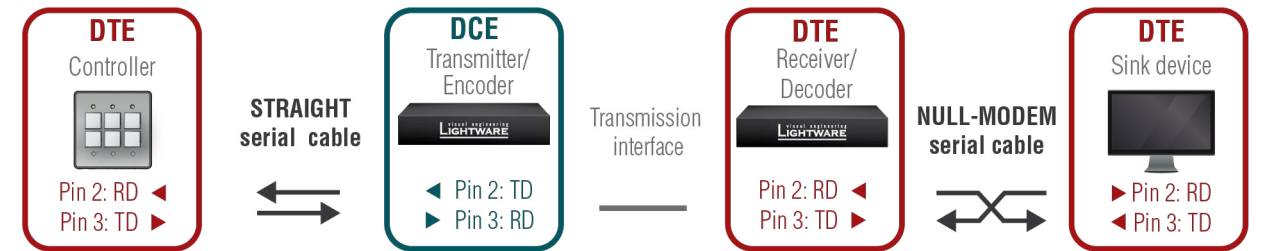

10

Appendix

Tables, drawings, guides, and technical details as follows:

- ▶ SPECIFICATIONS
- ▶ DELAY IN THE VIDEO TRANSMISSION
- ▶ FACTORY DEFAULT SETTINGS
- ▶ DIP SWITCH STATES
- ▶ MECHANICAL DRAWINGS
- ▶ RS-232 CABLE WIRING GUIDE
- ▶ SUPPORTED RESOLUTIONS
- ▶ FACTORY EDID LIST
- ▶ FIRMWARE RELEASE NOTES
- ▶ APPLICATION NOTE (LW-AN-001)
- ▶ **HASHTAG KEYWORD LIST**
- ▶ APPLIED PORTS (NETWORK SETTINGS)
- ▶ AUDIO PORT NUMBERING
- ▶ FURTHER INFORMATION

10.1. Specifications

10.1.1. VINX Basic Series

DIFFERENCE: Valid for VINX-120-HDMI-ENC and VINX-110-HDMI-DEC devices.

General

Compliance	CE, UKCA
Electrical safety	IEC/EN 62368-1:2014
EMC (emission)	IEC/EN 55032:2015
EMC (immunity)	IEC/EN 55035:2017
RoHS	EN 63000:2018
Warranty	3 years
Operating temperature	0° to +50°C (+32° to +122°F)
Operating humidity	10% to 90%, non-condensing
Cooling	Passive

Power

Power supply option	Power adaptor (supplied)
---------------------	--------------------------

VINX-110-HDMI-DEC

Power consumption (max)	5W
Heat dissipation (max)	17 BTU/h

VINX-120-HDMI-ENC

Power consumption (max)	8.5W
Heat dissipation (max)	29 BTU/h

Power adaptor

Supported power source	100-240 V AC; 50/60 Hz
Supplied power	5 V DC, 3A
AC power plug	Interchangeable (EU, UK, JP/US, AUS/NZ)
DC power plug	Locking DC connector (2.1/5.5 mm pin)

Enclosure

Enclosure material	1 mm steel
Dimensions in mm	100.4 W x 115 D x 26 H
Dimensions in inch	3.95 W x 4.53 D x 1.02 H
Weight	375 g

Video Input

HDMI Input Port

Connector type	19-pole HDMI type A receptacle
A/V standard	DVI 1.0, HDMI 1.4
HDCP Compliance	Yes, v2.2
Color space	RGB, YCbCr
Supported resolutions at 8 bits/color *	up to 3840x2160@30Hz (4:4:4) or 3840x2160@60Hz (4:2:0); 1920x1080@60Hz (4:4:4) up to 12 bits/color
3D signal support	'Side-by-side' and 'Top-to-bottom' modes
Audio formats	Embedded LPCM, Dolby Digital 5.1 ch, Dolby Digital Plus, Dolby Digital Pro-Logic, Dolby TrueHD, DTS:X, Dolby Atmos, DTS 5.1 ch, DTS 96/24, DTS-ES Discrete, DTS-ES Matrix, DTS-HD High Resolution Audio, DTS-HD Master Audio

Video Output

HDMI Output Port

Connector type	19-pole HDMI type A receptacle
A/V standard	DVI 1.0, HDMI 1.4
HDCP Compliance	v2.2
Color space	RGB, YCbCr
Supported resolutions at 8 bits/color *	up to 3840x2160@30Hz (4:4:4) or 3840x2160@60Hz (4:2:0), 1920x1080@60Hz (4:4:4) up to 12 bits/color
3D signal support	'Side-by-side' and 'Top-to-bottom' modes
Audio formats	Embedded LPCM, Dolby Digital 5.1 ch., Dolby Digital Plus, Dolby Digital Pro-Logic, Dolby TrueHD, DTS:X, Dolby Atmos, DTS 5.1 ch, DTS 96/24, DTS-ES Discrete, DTS-ES Matrix, DTS-HD High Resolution Audio, DTS-HD Master Audio

USB Ports

USB Port Type (Encoder)	mini-B type receptacle
USB Port Type (Decoder)	type-A receptacle, 4 pcs.
	2x USB 1.1 and 2x USB 2.0 compliant
Data Communication Mode	transparent

RS-232 Ports

Connector type	RJ12 female receptacle
Baud rates	300, 600, 1200, 2400, 4800, 9600, 19200, 38400, 57600, 115200 Baud
Data bits	6, 7, 8
Parity	None / Odd / Even
Stop bits	1 / 2
Data Communication Mode	Duplex, transparent

Infrared Ports

Output connector type (Encoder)	3.5 mm TS (1/8" jack)
Input connector type (Decoder)	3.5 mm TRS (1/8" jack)

10.1.2. VINX AP-series

DIFFERENCE: The specification data below refer to the VINX-120AP-HDMI-ENC-DNT, VINX-120AP-HDMI-ENC, VINX-210AP-HDMI-ENC and VINX-110AP-HDMI-DEC devices.

General

Compliance	CE, UKCA
Electrical safety	IEC/EN 62368-1:2014
EMC (emission)	IEC/EN 55032:2015
EMC (immunity)	IEC/EN 55035:2017
RoHS	EN 63000:2018
Warranty	3 years
Operating temperature	0° to +50°C (+32° to +122°F)
Operating humidity	10% to 90%, non-condensing
Cooling	Passive

Power

Power supply option	Power adaptor (supplied) / PoE
Power over Ethernet (PoE)	via AV in/out (IEEE802.3af)

VINX-110AP-HDMI-DEC

Power consumption (max)	5.2W
Heat dissipation (max)	18 BTU/h

VINX-120AP-HDMI-ENC

Power consumption (max)	7.5W
Heat dissipation (max)	25 BTU/h

VINX-120AP-HDMI-ENC-DNT

Power consumption (max)	8.2W
Heat dissipation (max)	28 BTU/h

VINX-210AP-HDMI-ENC

Power consumption (max)	8.3W
Heat dissipation (max)	28 BTU/h

Power adaptor

Supported power source	100-240 V AC; 50/60 Hz
Supplied power	12V DC, 1A DC
AC power plug	Interchangeable (EU, UK, JP/US, AUS/NZ)
DC power plug	Locking DC connector (2.1/5.5 mm pin)

Enclosure

Enclosure Material	1 mm steel
Dimensions in mm	221W x 105.3D x 26H
Dimensions in inch	8.7W x 4.14D x 1.02H
Weight	665 g

SFP Module Slot

Number of port	1
Supported data rate	1 Gbps
Accepted interfaces	SFP optical transceiver modules

Video Input**HDMI Input Port**

Connector type	19-pole HDMI type A receptacle
A/V standard	DVI 1.0, HDMI 1.4
HDCP Compliance	v2.2
Color space	RGB, YCbCr
Supported resolutions at 8 bits/color *	up to 3840x2160@30Hz (4:4:4) or 3840x2160@60Hz (4:2:0), 1920x1080@60Hz (4:4:4) up to 12 bits/color
3D signal support	'Side-by-side' and 'Top-to-bottom' modes
Audio formats	Embedded LPCM, Dolby Digital 5.1 ch, Dolby Digital Plus, Dolby Digital Pro-Logic, Dolby TrueHD, DTS:X, Dolby Atmos, DTS 5.1 ch, DTS 96/24, DTS-ES Discrete, DTS-ES Matrix, DTS-HD High Resolution Audio, DTS-HD Master Audio

VGA Input Port

Connector type	DE-15F (15-pole D-sub Female)
Supported video signal	Analog RGB and YPbPr video
Color depth	Up to 24 bits, 8 bit/color
Max. resolution	1680x1050@60 Hz

Video Output**HDMI Output Port**

Connector type	19-pole HDMI Type A receptacle
A/V standard	DVI 1.0, HDMI 1.4
HDCP compliance	HDCP 2.2
Color space	RGB, YCbCr
Supported resolutions at 8 bits/color *	up to 3840x2160@30Hz (4:4:4) or 3840x2160@60Hz (4:2:0), 1920x1080@60Hz (4:4:4) up to 12 bits/color
Audio formats	Embedded LPCM, Dolby Digital 5.1 ch, Dolby Digital Plus, Dolby Digital Pro-Logic, Dolby TrueHD, DTS:X, Dolby Atmos, DTS 5.1 ch, DTS 96/24, DTS-ES Discrete, DTS-ES Matrix, DTS-HD High Resolution Audio, DTS-HD Master Audio

USB Ports

USB Port Type (Encoder)	B type receptacle
USB Port Type (Decoder)	type-A receptacle, 4 pcs.
	2x USB 1.1 and 2x USB 2.0 compliant
Data Communication Mode	transparent
Data transmission rate (max)	5 MBit/s

RS-232 Ports

Serial Port Type	DE-9 (9-pole D-sub) connector
Baud rates	300, 600, 1200, 2400
	4800, 9600, 19200, 38400, 57600, 115200 Baud
Data bits	6, 7, 8
Parity	None / Odd / Even
Stop bits	1 / 2
Data Communication Mode	Duplex, transparent

Infrared Ports

Output connector type (Encoder)	3.5 mm TS (1/8" jack)
Input connector type (Decoder)	3.5 mm TRS (1/8" jack)

Analog Audio Input (VINX-120AP-HDMI-ENC and VINX-210AP-HDMI-ENC)

Connector type	3.5mm TRS (1/8" jack)
Audio formats	2-ch PCM
Sampling frequency	44.1 – 192 kHz
Signal transmission	unbalanced signal
Volume adjustment	-44 – 0 dB

Microphone Input (VINX-110AP-HDMI-DEC only)

Gain in the signal path *	+20dB
Peak level without distortion	-2.5dBFS (3% THD)
Total Harmonic Distortion (THD)	0.08% (refl: -12DBFS, 1kHz)
THD+Noise	0.3% (approx. -60dBFS)
Signal to Noise ratio (SNR)	62dBFS
Dynamic Range (DR)	72dBFS
Crosstalk	100% (mono channel)
Frequency response below 50Hz	above -3dB

* compared to the forward audio signal level. If this input is connected to a powered equipment, hum noise issue may occur. In this case an isolation transformer (a passive DI box) can help.

ATTENTION! The microphone input port applies a fixed bias to feed the connected electret (condenser) microphone. Thus, it is not suitable for dynamic microphones that do not contain isolation or an impedance matching transformer. (Danger of damage to the microphone.)

Analog Audio Output

Connector type	3.5mm TRS (approx. 1/8" jack)
Audio formats	2-ch PCM
Signal transmission	unbalanced signal
Sampling frequency	44.1 kHz – 192 kHz
Volume adjustment	-44 – 0 dB

Dante® Audio Output Port

Connector type	RJ45 female connector
Signal transmission	Dante® or AES67
Supported channels	2-channel stereo
Sampling rates	44.1, 48, 96 kHz

INFO: Specifications are subject to change without notice.

10.1.3. VINX Wall plate

DIFFERENCE: Valid for WP-VINX-110P-HDMI-ENC.

General

Compliance	CE, UKCA
Electrical safety	IEC/EN 62368-1:2014
EMC (emission)	IEC/EN 55032:2015
EMC (immunity)	IEC/EN 55035:2017
RoHS	EN 63000:2018
Warranty	3 years
Operating temperature	0° to +50°C (+32° to +122°F)
Operating humidity	10% to 90%, non-condensing
Cooling	Passive

Power

Power supply option	Power adaptor (optional accessory) / PoE
Power over Ethernet (PoE)	via AV in/out (IEEE802.3af)
Power consumption (max)	4.6W
Heat dissipation (max)	16 BTU/h

Enclosure

Enclosure material	1 mm steel
Dimensions in mm	116.3 W x 43.1 D x 115 H
Dimensions in inch	4.57 W x 1.7 D x 4.53 H
Weight	515 g

Video Input**HDMI Input Port**

Connector type	19-pole HDMI type A receptacle
A/V standard	DVI 1.0, HDMI 1.4
HDCP Compliance	HDCP 2.2
Color space	RGB, YCbCr
3D signal support	'Side-by-side' and 'Top-to-bottom' modes
Supported resolutions at 8 bits/color *	up to 4096x2160@30Hz (4:4:4) or 4096x2160@60Hz (4:2:0), up to 3840x2160@30Hz (4:4:4) or 3840x2160@60Hz (4:2:0), 1920x1080@60Hz (4:4:4) up to 12 bits/color
Audio formats	Embedded LPCM, Dolby Digital 5.1 ch, Dolby Digital Plus, Dolby Digital Pro-Logic, Dolby TrueHD, DTS:X, Dolby Atmos, DTS 5.1 ch, DTS 96/24, DTS-ES Discrete, DTS-ES Matrix, DTS-HD High Resolution Audio, DTS-HD Master Audio

Video Output

Connector type	RJ45 connector
Power Over Ethernet	yes (IEE 802.3af)
HDCP Compliance	v2.2
Color space	RGB, YCbCr
Supported resolutions at 8 bits/color *	up to 4096x2160@30Hz (4:4:4) or 4096x2160@60Hz (4:2:0), up to 3840x2160@30Hz (4:4:4) or 3840x2160@60Hz (4:2:0) 1920x1080@60Hz (4:4:4) up to 12 bits/color
3D signal support	'Side-by-side' and 'Top-to-bottom' modes
Audio formats	8 channel PCM, Dolby TrueHD, DTS-HD Master Audio7.1
USB Ports	
USB Port Type	B type receptacle
Data Communication Mode	transparent
Data transmission rate (max)	5 MBit/s

10.2. Delay in the Video Transmission

Due to the design of the devices, frame delay is in the signal transmission from the Encoder towards the Decoder. The tables below show the cases and the measurable delay.

No Scaling, No Frame Rate Conversion

Input resolution	Output resolution	Delay	Frame delay
1080p60	1080p60	19ms	1.1
1080p50	1080p50	22ms	1.1
2160p25	2160p25	45ms	1.1
720p60	720p60	19ms	1.1

After the receiver got the signal, there is a synchronizing period (approx. 30 sec), then the frame delay stays constant as written above.

Active Scaling, No Frame Rate Conversion

Input resolution	Output resolution	Delay	Frame delay
720p60	1080p60	19ms	1.1
1280x960p60	1080p60	19ms	1.1
1080p25	2160p25	47ms - 100ms	
720p25	2160p25	47ms - 100ms	
1080p60	720p60	19ms	1.1
1080p30	2160p30	38ms	1.1

After the receiver got the signal, there is a synchronizing period (approx. 30 sec), then the frame delay stays constant as written above.

Active Frame Rate Conversion (Scaling Does Not Matter)

Input resolution	Output resolution	Delay (min)	Delay (max)
1080p60	1080p50	18ms	50ms
1080p29.97	1080p50	50ms	80ms
720p29.97	1080p50	50ms	80ms
720p29.97	2160p25	50ms	110ms
720p24	2160p25	70ms	110ms
1080p50	720p60	45ms	55ms

10.3. Factory Default Settings

Parameter	Setting/Value
IP address	Dynamic (AutoIP with DHCP fallback)
RS-232 port setting	115200 BAUD, 8, N, 1
DIP switch state	0000
Video stream ID	1
Connecting method	Multicast mode
Selected video input (VINX-210AP-HDMI-ENC)	Auto
Selected audio input	Auto#1
Emulated EDID (HDMI input)	F47 (Universal HDMI EDID)
Emulated EDID (VGA input)	F89 (Universal Analog EDID)
User EDID memory	Empty (cleared)
Output video mode (Encoder)	Movie mode
Output scaling (Decoder)	Pass-through, no rotation
Available video walls	Empty (cleared)

10.4. DIP Switch States

DIP switch state	Video Stream ID	/SYS/MB/GPIO.DipSwitch value
0000	SW setting	0x0
0001	1	0x1
0010	2	0x2
0011	3	0x3
0100	4	0x4
0101	5	0x5
0110	6	0x6
0111	7	0x7
1000	8	0x8
1001	9	0x9
1010	10	0xa
1011	11	0xb
1100	12	0xc
1101	13	0xd
1110	14	0xe
1111	15	0xf

10.5. Mechanical Drawings

The dimensions are in mm. Encoder and Decoder devices have the same size of chassis. The basic VINX devices are built into quarter-rack sized chassis, the AP-series have half-rack sized chassis.

Half-rack Sized Models

Front View

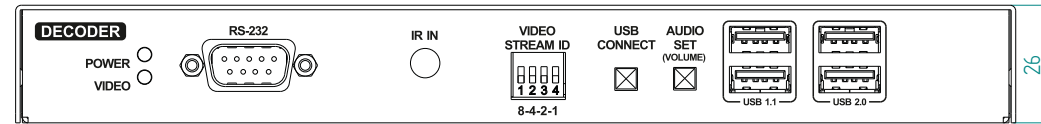

Top View

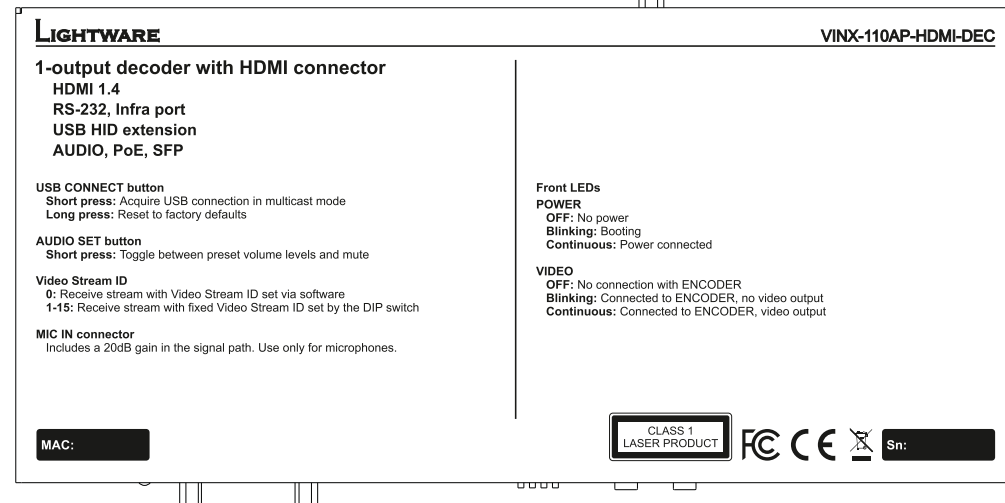

Rear View



Side View

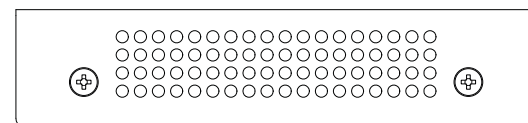

Bottom View

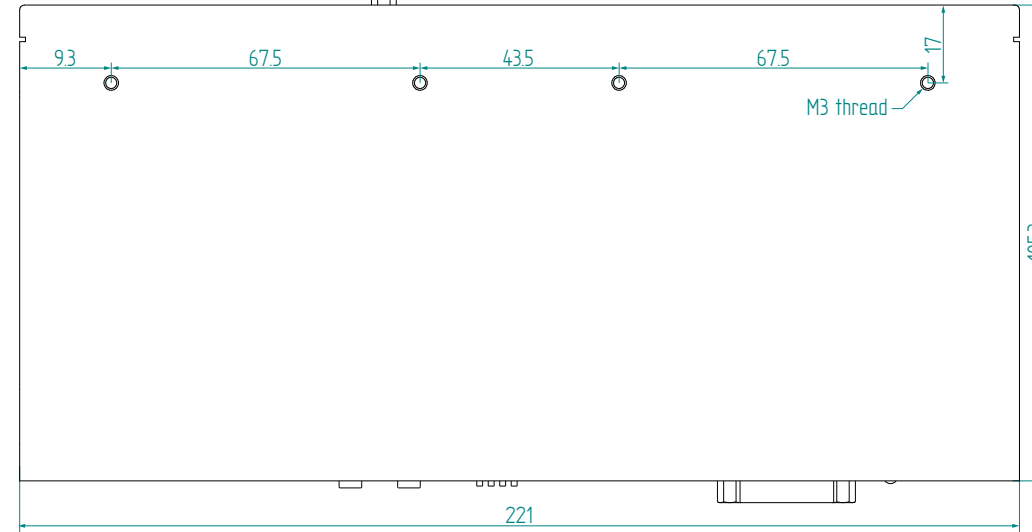

Quarter-rack Sized Models

Front View

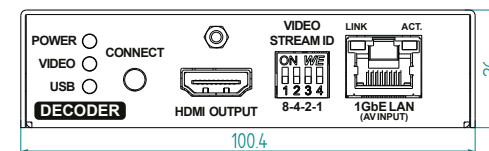

Rear View

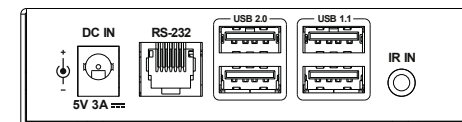

Side View

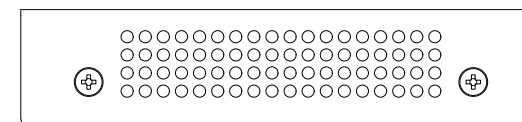

Top View

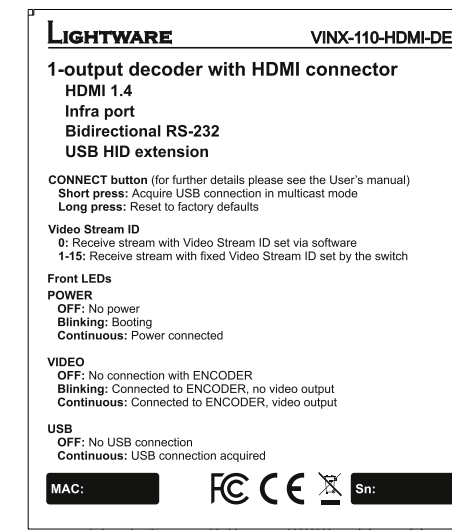

Bottom View

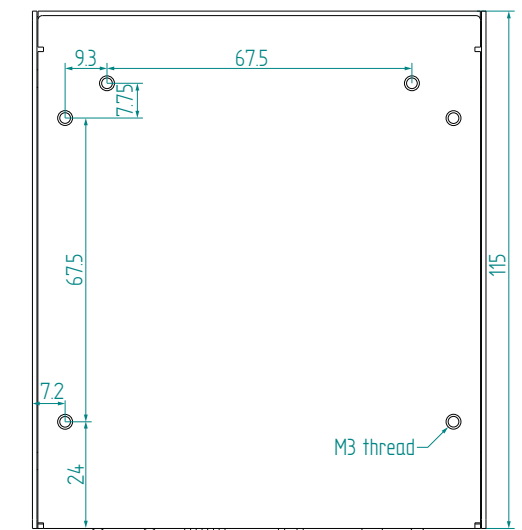

Wall plate model

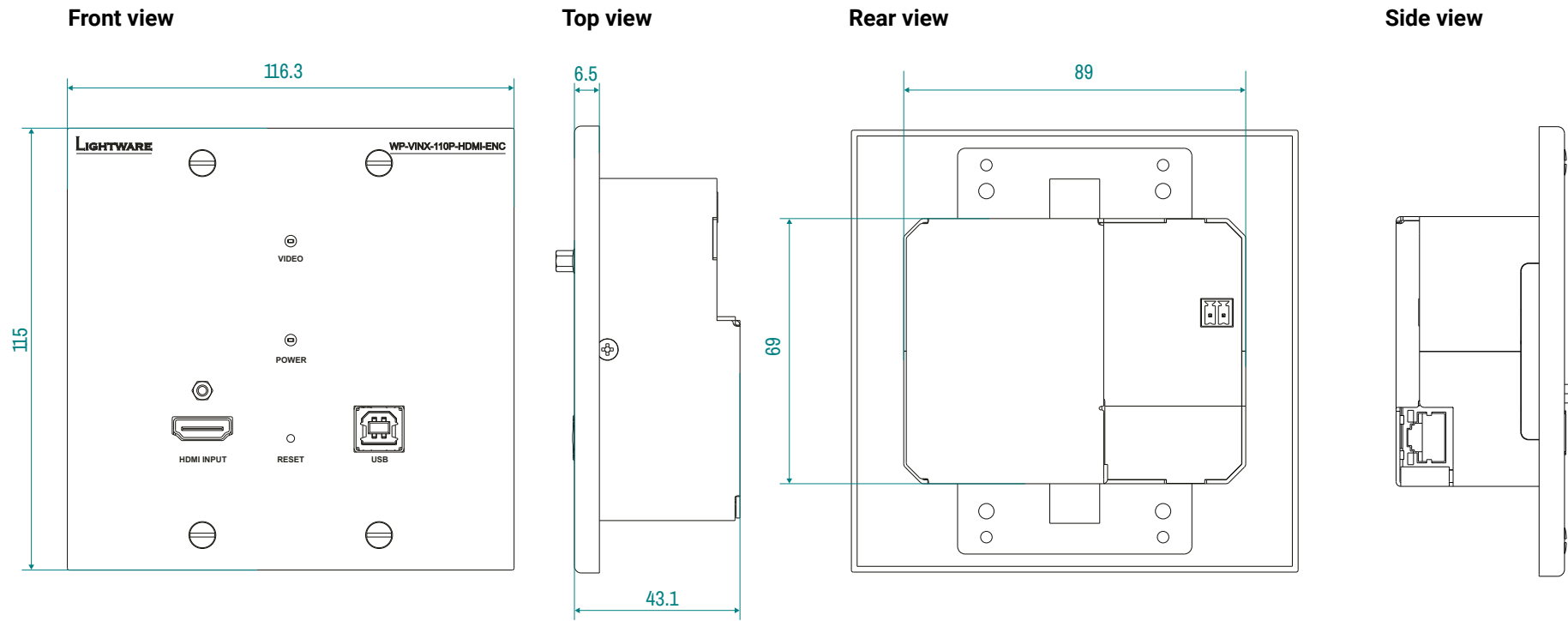

10.6. RS-232 Cable Wiring Guide

The Pinout of a DE-9 Type Serial Connector

The DE-9 type (D-subminiature, or D-sub) male or female connector is also used for RS-232 serial communication. There are two types of devices in general serial communication:

Data Terminal Equipment (DTE): This is an end instrument that converts user information into signals or reconverts received signals. Typical DTE devices: computers, LCD touch panels and control systems.

Data Circuit-terminating Equipment (DCE): This kind of device is placed between the DTE and a data transmission circuit. It is also called data communication equipment and data carrier equipment. Typical DCE devices: projectors, industrial monitors and amplifiers.

The pinout of DTE and DCE devices are different:

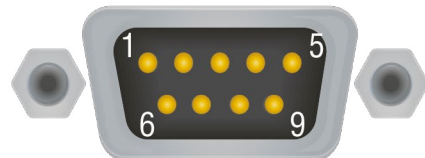

Pin nr.	Signal
1	NC (not connected)
2	RX data receive (input)
3	TX data transmit (output)
4	DTR (internally connected to pin6)
5	GND signal ground (shield)
6	DSR (internally connected to pin4)
7	RTS (internally connected to pin8)
8	CTS (internally connected to pin7)
9	NC (not connected)

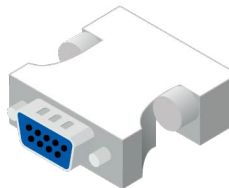
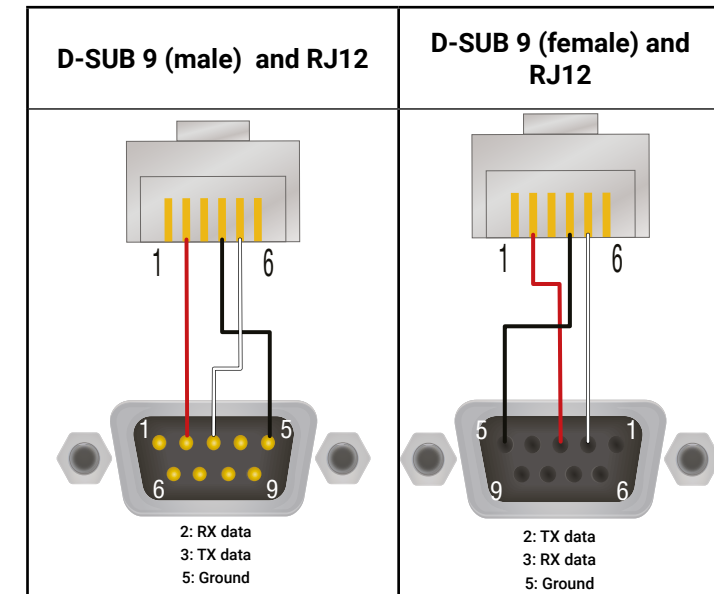
10.7. Supported Resolutions

Resolution	Frame rate
640x350	70
640x350	85
640x400	85
640x480	50
640x480	60
640x480	67
640x480	72
640x480	75
640x480	85
720x240	60
720x240	120
720x240	240
720x288	50
720x288	100
720x288	200
720x400	70
720x400	85
720x480 (480p)	60
720x480	120
720x480	240
720x576 (576p)	50
720x576	100
720x576	200
768x480	50
768x480	60
768x480	75
768x480	85
800x600	50
800x600	56
800x600	60

Resolution	Frame rate
800x600	72
800x600	75
800x600	85
832x624	75
834x624	75
848x480	50
848x480	60
848x480	75
848x480	85
852x480	60
960x600	50
960x600	60
960x600	75
960x600	85
1024x384	87
1024x576	60
1024x768	50
1024x768	60
1024x768	70
1024x768	75
1024x768	85
1064x600	50
1064x600	60
1064x600	75
1064x600	85
1152x720	50
1152x720	60
1152x720	75
1152x720	85
1152x864	60

Resolution	Frame rate
1152x864	75
1152x864	85
1152x864	100
1152x870	75
1224x768	50
1224x768	60
1224x768	75
1224x768	85
1280x720	24
1280x720	25
1280x720	30
1280x720 (720p)	50
1280x720 (720p)	60
1280x720 (720p)	75
1280x720	85
1280x720	100
1280x720	120
1280x768	50
1280x768	60
1280x768	75
1280x768	85
1280x800	60
1280x800	75
1280x800	85
1280x960	50
1280x960	60
1280x960	75
1280x960	85
1280x1024	50
1280x1024	60

Resolution	Frame rate
1280x1024	75
1280x1024	85
1280x1024	96
1280x1470	24
1280x1470	30
1280x1470	50
1280x1470	60
1360x768	50
1360x768	60
1360x768	75
1360x768	85
1365x1024	60
1365x1024	75
1366x768	60
1400x788	60
1400x1050	50
1400x1050	60
1400x1050	75
1400x1050	85
1440x240	60
1440x288	50
1440x480	60
1440x576	50
1440x900	60
1440x900	75
1440x900	85
1440x960	72
1536x960	50
1536x960	60
1536x960	75

Resolution	Frame rate
1536x960	85
1600x900	60
1600x1024	60
1600x1200	50
1600x1200	60
1600x1200	65
1600x1200	70
1600x1200	75
1600x1200	85
1600x1200	120
1680x1050	50
1680x1050	60
1680x1050	75
1680x1050	85
1704x960	50
1704x960	60
1704x960	75
1704x960	85
1728x1080	50
1728x1080	60
1728x1080	75
1728x1080	85
1792x1344	60
1792x1344	75
1856x1392	60
1856x1392	75
1860x1050	50
1860x1050	60
1860x1050	75
1860x1050	85

Resolution	Frame rate
1920x540	50
1920x540	120
1920x540	100
1920x1080	24
1920x1080i	25
1920x1080i	29.97
1920x1080	30
1920x1080 (1080p)	50
1920x1080 (1080p)	60
1920x1080	75
1920x1080	85
1920x1200	50
1920x1200	60
1920x1200	75
1920x1200	85
1920x1440	50
1920x1440	60
1920x1440	75
1920x2205	24
1920x2205	30
1920x2205	50
1920x2205	60
2048x1152	60
2048x1280	60
2048x1536	50
2048x1536	60
2128x1200	50
2128x1200	60
2128x1200	75
2304x1440	50

Resolution	Frame rate
2304x1440	60
2456x1536	50
2560x1080	24
2560x1080	25
2560x1080	30
2560x1080	50
2560x1080	60
2560x1200	30
2560x1200	60
2560x1440	50
2560x1600	60
2728x1536	50
3840x2160	24
3840x2160	25
3840x2160	30
2840x2160	50
3840x2160	60
4096x2160	24
4096x2160	25
4096x2160	30
4096x2160	50
4096x2160	60

10.8. Factory EDID List

Mem	Resolution	Type	EDID features
F1	640 x 480p @ 60.00 Hz	D	
F3	800 x 600p @ 60.32 Hz	D	
F4	1024 x 768p @ 60.00 Hz	D	
F5	1280 x 768p @ 50.00 Hz	D	
F6	1280 x 768p @ 59.94 Hz	D	
F7	1280 x 768p @ 75.00 Hz	D	
F8	1360 x 768p @ 60.02 Hz	D	
F9	1280 x 1024p @ 50.00 Hz	D	
F10	1280 x 1024p @ 60.02 Hz	D	
F11	1280 x 1024p @ 75.02 Hz	D	
F15	1680 x 1050p @ 60.00 Hz	D	
F16	1920 x 1080p @ 50.00 Hz	D	
F17	1920 x 1080p @ 60.00 Hz	D	
F20	1600 x 1200p @ 50.00 Hz	D	
F21	1600 x 1200p @ 60.00 Hz	D	
F22	1920 x 1200p @ 50.00 Hz	D	
F23	1920 x 1200p @ 59.56 Hz	D	
F29	1920 x 1080p @ 60.00 Hz	U	
F32	640 x 480p @ 59.95 Hz	H	2chLPCM
F33	720 x 480p @ 59.94 Hz	H	2chLPCM
F34	720 x 576p @ 50.00 Hz	H	2chLPCM
F35	1280 x 720p @ 50.00 Hz	H	2chLPCM
F36	1280 x 720p @ 60.00 Hz	H	2chLPCM
F37	1920 x 1080i @ 50.04 Hz	H	2chLPCM
F38	1920 x 1080i @ 50.00 Hz	H	2chLPCM
F39	1920 x 1080i @ 60.05 Hz	H	2chLPCM
F40	1920 x 1080i @ 60.05 Hz	H	2chLPCM
F41	1920 x 1080p @ 24.00 Hz	H	2chLPCM
F42	1920 x 1080p @ 25.00 Hz	H	2chLPCM
F43	1920 x 1080p @ 30.00 Hz	H	2chLPCM

Mem	Resolution	Type	EDID features
F44	1920 x 1080p @ 50.00 Hz	H	2chLPCM
F45	1920 x 1080p @ 59.94 Hz	H	2chLPCM
F46	1920 x 1080p @ 60.00 Hz	H	2chLPCM
F47	1920 x 1080p @ 60.00 Hz	U	2chLPCM
F48	1920 x 1080p @ 60.00 Hz	U	2chLPCM, 8chLPCM, DD, DTS, AAC, DD+, DTS-HD, MLP, DST, WMAP
F49	1920 x 1080p @ 60.00 Hz	U	2chLPCM, 8chLPCM, DD, DTS, AAC, DD+, DTS-HD, MLP, DST, WMAP
F50	720 x 480i @ 30.03 Hz	A	
F51	720 x 576i @ 25.04 Hz	A	
F52	640 x 480p @ 60.00 Hz	A	
F53	640 x 480p @ 75.00 Hz	A	
F54	800 x 600p @ 50.00 Hz	A	
F55	800 x 600p @ 60.32 Hz	A	
F56	800 x 600p @ 75.00 Hz	A	
F57	1024 x 768p @ 49.99 Hz	A	
F58	1024 x 768p @ 60.00 Hz	A	
F59	1024 x 768p @ 75.03 Hz	A	
F60	1280 x 768p @ 50.00 Hz	A	
F61	1280 x 768p @ 59.94 Hz	A	
F62	1280 x 768p @ 75.00 Hz	A	
F63	1360 x 768p @ 60.02 Hz	A	
F64	1364 x 768p @ 50.00 Hz	A	
F65	1364 x 768p @ 59.94 Hz	A	
F66	1364 x 768p @ 74.99 Hz	A	
F67	1280 x 1024p @ 50.00 Hz	A	
F68	1280 x 1024p @ 60.02 Hz	A	
F69	1366 x 1024p @ 60.00 Hz	A	
F70	1400 x 1050p @ 50.00 Hz	A	
F71	1400 x 1050p @ 60.00 Hz	A	
F72	1400 x 1050p @ 75.00 Hz	A	
F73	1920 x 540i @ 50.00 Hz	A	

Mem	Resolution	Type	EDID features
F74	1920 x 540i @ 60.00 Hz	A	
F75	1920 x 1080p @ 50.00 Hz	A	
F76	1920 x 1080p @ 60.00 Hz	A	
F89	1920 x 1200p @ 59.56 Hz	U	
F96	2560 x 1600p @ 59.86 Hz	D	
F100	1024 x 768p @ 60.00 Hz	H	2chLPCM
F101	1280 x 1024p @ 50.00 Hz	H	2chLPCM
F102	1280 x 1024p @ 60.02 Hz	H	2chLPCM
F103	1280 x 1024p @ 75.02 Hz	H	2chLPCM
F104	1600 x 1200p @ 50.00 Hz	H	2chLPCM
F105	1600 x 1200p @ 60.00 Hz	H	2chLPCM
F106	1920 x 1200p @ 59.56 Hz	H	2chLPCM
F108	2560 x 1600p @ 59.86 Hz	H	2chLPCM
F110	3840 x 2160p @ 24.00 Hz	H	2chLPCM
F111	3840 x 2160p @ 25.00 Hz	H	2chLPCM
F112	3840 x 2160p @ 30.00 Hz	H	2chLPCM
F118	3840 x 2160p @ 30.00 Hz	U	2chLPCM
F119	3840 x 2160p @ 30.00 Hz	U	2chLPCM, 8chLPCM, DD, DTS, AAC, DD+, DTS-HD, MLP, DST, WMAP
F125	1366 x 768p @ 60.00 Hz	H	2chLPCM
F131	4096 x 2160p @ 25.00 Hz	H	2chLPCM
F132	4096 x 2160p @ 30.00 Hz	H	2chLPCM

Legend

D: DVI EDID

H: HDMI EDID

U: Universal EDID, supporting many standard resolutions:

- **F29:** Universal EDID for DVI signals (no audio support).
- **F47:** HDMI EDID supporting PCM audio.
- **F48:** HDMI EDID supporting all type of audio.
- **F49:** HDMI EDID supporting all type of audio and deep color.
- **F89:** Universal EDID for analog signals (no audio support).
- **F118:** HDMI EDID supporting PCM audio and 4K@30 Hz signals.
- **F119:** HDMI EDID supporting all type of audio and 4K@30 Hz signals.

10.9. Firmware Release Notes

The list below shows the released firmware packages with important notes.

v3.4.0b3

Release date: 2022-11-08

New feature:

- Fixed the USB shortcut issue
- Fixed the reset button function in case of the VINX wallplate

Bugfix:

- Fixed the default input interface (HDMI) in case of the VINX wallplate
- Fixed a routing issue between different subnets when DHCP server is on.
- Fixed the audio disappearing issue after renewal of the IP address

v3.3.1b2

Release date: 2022-09-14

Bugfix:

- Fixed the IP setting issue after factory reset in case of VINX-110-HDMI-DEC device.

v3.3.0b5

Release date: 2022-08-31

New feature:

- Added feature to switch off video output on decoder to cut off outgoing video signal.
- Improved performance in large VINX systems with 100+ endpoints. Fixed switching time slowdown.
- Resetting to factory defaults with front panel button is modified to prevent accidental resets. Button long press resets to defaults only during 90 seconds after startup.

v3.1.1b4

Release date: 2022-05-04

New feature:

- From this version on, the value of Video stream ID can be as high as 9999. Consequently, the number of encoders in the system can be 9999.
- From this version on, login to the VINX devices can be made password protected.
- Improved the update process.

Bugfix:

- Fixed a bug that caused the VINX splash screen to be overlaid over the video content on the decoder output.
- Fixed a bug that resulted in a video wall pictogram with the wrong video wall size in the Properties pane of the Crosspoint view.

- Fixed a bug that caused a change in the Video stream ID on the decoder not to be executed when the encoder was restarted or the connection to the encoder was temporarily lost for some other reason.
- Fixed a bug that caused the crosspoint not to be rendered correctly if there was a video wall defined somewhere in the subnet.
- Fixed a bug that prevented the Frame detector data from being copied from the embedded web.

Known issue:

- When using Apple TV 4k or other Apple product as a video source with the VINX-120AP-HDMI-ENC, VINX_210AP-HDMI-ENC or VINX- 120AP-HDMI-ENC-DNT encoder, the HDCP handshake might not be successful and no video would be transmitted unless a DVI EDID (e.g. from the factory EDIDs) is emulated first towards the video source. After emulation of the DVI EDID, any new EDID emulated towards the video source will result in successful HDCP handshake and proper video transmission until the Apple TV 4k device is restarted.
- It might happen that the VINX splash screen is briefly shown on the output of the decoder when a previously broken link to the corresponding encoder is restored.

v3.0.1b8

Release date: 2021-12-10

New feature:

- From this version on, the limit on the number of devices supported in the crosspoint view is lifted. Thus, the crosspoint view can display all devices in the subnet.
- From this version on, three custom images can be uploaded on the VINX decoders. These images can be used as company logos whenever the connection to the encoder is lost or there is no video from the encoder.
- From this version on, the WP-VINX-110P-HDMI-ENC (VINX wallplate version) is also supported.
- From this version on, the crosspoint has a tile view of the inputs and outputs with the respective preview images displayed on the tiles.

Known issue:

- If the DIP switch is disabled by setting the 'DipSwitchEnable' property to false and the DIP switch setting is other than '0000', the Video Stream Id cannot be set from software through LW3 or the graphical user interface.
- It might take an unusually long time to display the crosspoint view when there are more than 100 VINX devices in the subnet.
- The Frame detector data cannot be copied from the embedded web. The same data can be copied from LDC, though.
- It might happen that the VINX splash screen is overlaid over the company logo.
- The extension of the image file to be uploaded as company logo is case sensitive. Use lower case extension to avoid the problem.
- The available space for storing company logos is erroneously reported as 0 (under StorageFreeSize) if no image file for company logo is uploaded.

v2.0.2b4

Release date: 2021-01-12

New feature:

- From this version on, black screen or the VINX screen can be selected to display when there is no video signal in the decoder.

v2.0.1b3

Release date: 2020-02-19

Bugfix:

- Fixed a bug that caused popping sound on analog audio output when changing streams

Known issue:

- On a VINX-110AP-HDMI-DEC, when both USB 2.0 ports are used, the analog audio signal on the output might be jammed during stream change

v2.0.0b27

Release date: 2020-01-16

New feature:

- Factory defaults button added to Advanced Setup page.
- From this version on, the firmware supports the VINX-120AP-HDMI-ENC-DNT encoder.
- From this version on, the device can be set to use static IP address, use dynamic IP address either with or without falling back to AutoIP, or continue with dynamic IP address query even after AutoIP was set.
- From this version on, the HPD signal on the HDMI input of an encoder can be toggled.
- Improved switching time considerably. (Switching time is the time elapsed between switching to another source and providing a stable output on the output HDMI port.)

Bugfix:

- Fixed a bug that resulted in some LW3 requests not to be executed when the sender closed the TCP connection before receiving an answer for the request from the VINX device.

v1.4.1b2

Release date: 2019-07-03

Bugfix:

- Fixed a bug that caused the IP related settings to be restored to their factory default values (to DHCP) when upgrading to v1.4.0.

v1.4.0b7

Release date: 2019-07-05

New feature:

- Added support for VINX-210AP-HDMI-ENC, VINX-120AP-HDMI-ENC, and VINX-110AP-HDMI-DEC.
- From this version on, the exact product name is presented to the user in the header of the built-in web and in LDC.
- From this version on, both the encoder and the decoder can be set whether or not to use jumbo frames. Note, that this setting is only available from LW3 and the decoder and the corresponding encoder shall be set to the same setting.

Bugfix:

- Fixed a bug that might have resulted in the Advanced Settings page to be rendered incorrectly at some resolutions.

Known issue:

- Pressing the front panel key (COMP MODE or USB CONNECT) for less than ten seconds might reset the device to its factory settings.
- On a VINX-120-HDMI-ENC device, The EDID is not read from the sink connected to the local output of the encoder. Thus, it cannot be used as a dynamic EDID.
- Some parameters of the EDID emulated on the HDMI input of VINX-210AP-HDMI-ENC and VINX-120AP-HDMI-ENC (other than the preferred timing) might get modified.
- VINX-210AP-HDMI-ENC might indicate wrong resolution for incoming analog signals with frame rate of 50 Hz.
- On a VINX-110AP-HDMI-DEC, compressed audio might be output for a brief period of time which results in digital noise on the output.

v1.3.0b5

Release date: 2018-12-18

New feature:

- Added controls for setting the RS-232 mode to Pass-through or Command injection.
- Added a Crosspoint tab to the graphical user interface. In the crosspoint tab it is possible to route any input to any output as long as the number of encoders and decoders in the subnet does not exceed 24 and the number of encoders is less or equal to 16.

Bugfix:

- Fixed a bug that caused the firmware upgrade to stop at 20% when upgrading through LDU2.
- Fixed a bug that caused the Output scaling radio button group to work hectically when the Output standard is set to DVI.

v1.2.1b1

Release date: 2018-10-24

Bugfix:

- Fixed a bug that resulted in wrong output format for scaling set to 1920x1080@50Hz.

v1.2.0b9

Release date: 2018-10-18

New feature:

- From this version on, the video mode related settings (Video quality as referred to in earlier versions) have been given a more descriptive and self explaining name.
- The Connect button in the Main Settings page has been renamed to Open Device.
- From this version on VINX devices are supported by the Lightware Device Manager.
- From this version on, the graphical user interface displays a preview image of the encoder input.
- Improved response time of the devices. As a result, changes made to the devices are reflected faster on the graphical user interface.
- The list of available output formats has been consolidated and a few output formats have been added.
- From this version on, the name of the device appears on the tab of the Programmers' LW3 Terminal window.

Bugfix:

- Fixed a bug that caused the video not to be transmitted properly in Unicast mode when switching Video Stream ID on the encoder.
- Fixed a bug that caused the Auto detect from EDID scaler feature not to work properly after a factory reset.
- Fixed a bug that caused the device to switch to Unicast mode from Multicast mode only at the second click on the corresponding button on the Advanced Settings page.
- Fixed a bug that let the user select two decoders to receive the same video stream in Unicast mode.
- Fixed a bug that caused the connection to the device to be lost when changing Video Stream ID on the decoder multiple times in rapid succession.
- Fixed a bug that caused the USB LED on the decoder not to reflect valid information when pressing the Connect button on several decoders connected to the same encoder in rapid successions multiple times.
- Added a warning message to state that the device having an Auto IP of 169.254.x.x cannot be detected after firmware upgrade as the IP address will change after a reboot.
- Fixed a bug that caused the Delete video wall button on the Video Wall Setup page to be active even if there is no video wall selected.
- Fixed a bug that let the user enter invalid value for stop bit in the LW3 tree view.

- Fixed a bug that caused the IGMP packets to be disregarded by certain switches due to missing Router Alert option from the IP header. Thus, it is no longer necessary to disable IP header validation on the switches.
- Fixed a bug that caused connection reset during firmware upgrade by LDU2.
- Fixed a bug that caused the Programmers' LW3 Terminal window to be rendered incorrectly at certain resolutions.

Known issue:

- The video wall being edited can lose focus when it is saved.
- The Output scaling radio button group works hectically when the Output standard is set to DVI.

v1.1.1b2

Release date: 2018-06-07

Bugfix:

- Fixed a bug that degraded switching speed.

v1.1.0b7

Release date: 2018-05-31

New feature:

- From this version on, the items in the Emulated EDID on input list reflect the monitor name field of the EDID instead of the format parameters for better identification.
- New EDIDs have been added to the factory EDID list.
- From this version on, the OSD messages that appear on the display connected to the VINX decoder are turned off by default. They can be turned on individually or globally, though.
- From this version on, information like the IP address of a decoder and the position within a video wall can be temporarily displayed on the monitor attached to a VINX decoder. This will ease the setup of video walls.
- For smooth video playback, the default operation mode has been changed from Graphic Mode to Video Mode.
- From this version on, VINX encoder and decoder units can be upgraded in batches by LDU2.
- It is now possible to disable (by an LW3 property) the DIP switch setting of the video stream ID.
- Version number of several components including package version has been added to the graphical user interface.
- It is now possible to set bandwidth limit for the encoded video stream generated by the encoder.
- It is now possible to create a list of favourite channels and associate shortcut keys to cycle through the list up and down. Moreover, shortcut keys can be associated with specific streams. The associated shortcut key, when pressed on a keyboard attached to a decoder, can be used to trigger the corresponding action.
- It is now possible to connect to an encoder from a decoder or to a decoder from an encoder by clicking on a Connect button in the list of available devices on the Main Settings page.

Bugfix:

- Fixed a bug that caused VINX-HDMI-120-ENC and VINX-HDMI-110-DEC not to be accessible via <http://lwr-gatewayAABBCCDDEEFF.local> or <http://lwr-clientAABBCCDDEEFF.local>, respectively, where AABBCCDDEEFF is the MAC address without colons of the device to be accessed.
- Fixed a bug that caused a decoder device to display invalid content when it was removed from a video wall.
- Fixed a bug that caused the VINX encoder to restart when the corresponding decoder was reading an EDID from the attached device that had a Video Format Preference block in its CEA extension.
- Fixed a bug that caused the RS-232 symbol rate not to be displayed correctly when a custom value was set via LW3.

Known issue:

- When defining a shortcut key combination for switching to previous or next stream or for a stream shortcut, and the shortcut key combination has more modifier keys, the box containing the key combination might get truncated.
- When an encoder is switched to Unicast mode and restarted, it still can receive the USB stream coming from a decoder in Multicast mode and having the same Video Stream ID.
- The Programmers' LW3 Terminal window might get rendered incorrectly at certain resolutions.
- When dragged at certain pixel positions it is impossible to move an item from the tile representing a video wall element on the Video Wall Setup page.
- Switching source or destination through the Device list pane on the Main Settings page of the encoder or decoder might take more time compared to switching directly by modifying the ID in the Video stream ID box.

v1.0.0b11

Release date: 2017-12-14

Known issue:

- The same Video Stream ID can be set on multiple VINX-120-HDMI-ENC devices that results in an UDP packet collision and erroneous video transmission.
- Neither VINX-HDMI-120-ENC, nor VINX-HDMI-110-DEC can be accessed via <http://lwr-gatewayAABBCCDDEEFF.local> or <http://lwr-clientAABBCCDDEEFF.local>, respectively, where AABBCCDDEEFF is the MAC address without colons of the device to be accessed.
- EDID information cannot be read by the source attached to the HDMI input of a VINX-120-HDMI-ENC device if HDCP is disabled on the input.
- Only 225.0.1.x can be selected as a multicast base address.
- Although changing parameters usually takes effect within an acceptable period of time, it might happen that feedback is not received for up to several seconds. This can result in uncertainty on the graphical user interface. This is the reason why e.g. a video wall seemingly still exists although it has already been deleted.

10.10. Application Note (LW-AN-001)

Gigabit Network Switch Requirements For VINX Devices

Network Properties

Network-based AV products use different network protocols for different operations. The network protocol can be UDP/IP and TCP/IP, the transmission mode can be Broadcast, Unicast, and Multicast.

These network protocols should be familiar to any network engineer. Because our network-based AV solutions bridge the gap between the audio-visual (AV) and information technology (IT) worlds, Lightware suggests involvement of both AV and IT departments in any installation.

Lightware products are designed to be plug-and-play. The figures in the next section illustrate the basic installation of one Decoder and one Encoder. A video source provides the digital video content to the Encoder which converts it to Ethernet packets and sends it to the attached Decoder. The Decoder reconstitutes the video with synchronized audio for presentation to the attached display.

Point-to-point vs Network Connection

VINX Encoders and Decoders have two typical applications:

- Point-to-point connection
- Point-to-multi point connection

Point-to-point Connection (Unicast mode)

Unicast transmission mode uses a one-to-one association between the source and the destination: each destination address uniquely identifies a single Decoder endpoint.



Point-to-Multi Point Connection (Multicast mode)

Multicast transmission mode uses a one-to-one or one-to-many association; multicast datagrams are forwarded simultaneously in a single transmission to many recipients through L2 switched network. There can be multiple encoders in a L2 subnet. The decoders have to be in the same subnet.



Unicast Routing

The packet forwarding requirement of the VINX devices for point-to-point connection is the unicast switching. Please note that the unicast mode is not the default setting of the Encoder and Decoder, users have to set it in the devices.

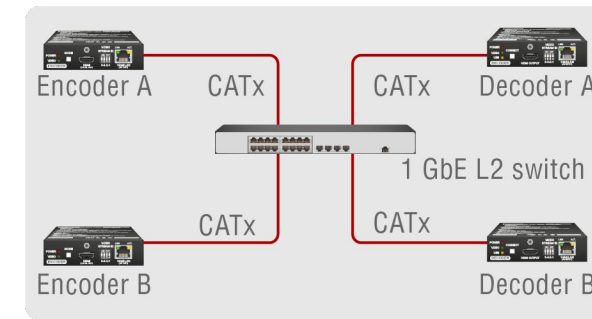

Hardware Requirement:

- 1 GbE Layer 2 (L2) switch

ATTENTION! VINX devices send certain system commands over multicast packages. If the multicast packet forwarding is disabled on the network, the signal transmission can fail.

Managed Switch for Multicast Routing

In TCP/IP terminology, Layer 2 is the data link layer that is responsible for splitting the information coming from higher layers in the TCP/ IP stack into Ethernet frames. An Ethernet frame includes, among others, labeling information with source and destination physical addresses (called source and destination MAC address). These physical addresses uniquely identify the source and destination physical devices (e.g. a VINX Encoder and a VINX Decoder). Ethernet frames provide error resilience by incorporating a redundancy check field, through which transmission errors can easily be detected. The device that uses only the physical address information found in the Ethernet frame to forward a packet from one of its input ports to one or more of its output ports is an unmanaged switch.

A managed switch, on the other hand, can handle the traffic and forward input packets to output packets by utilizing information from higher layers. This gives the managed switch more flexibility and also allows for more sophisticated functions like multicast forwarding. Since even a simple VINX network, where one VINX Encoder supplies more VINX Decoders, relies on multicasting, a multicast capable switch (i.e. a managed one) is mandatory. If non-managed switches transmit the multicast packages, the multicast traffic is usually broadcasted over all interfaces.

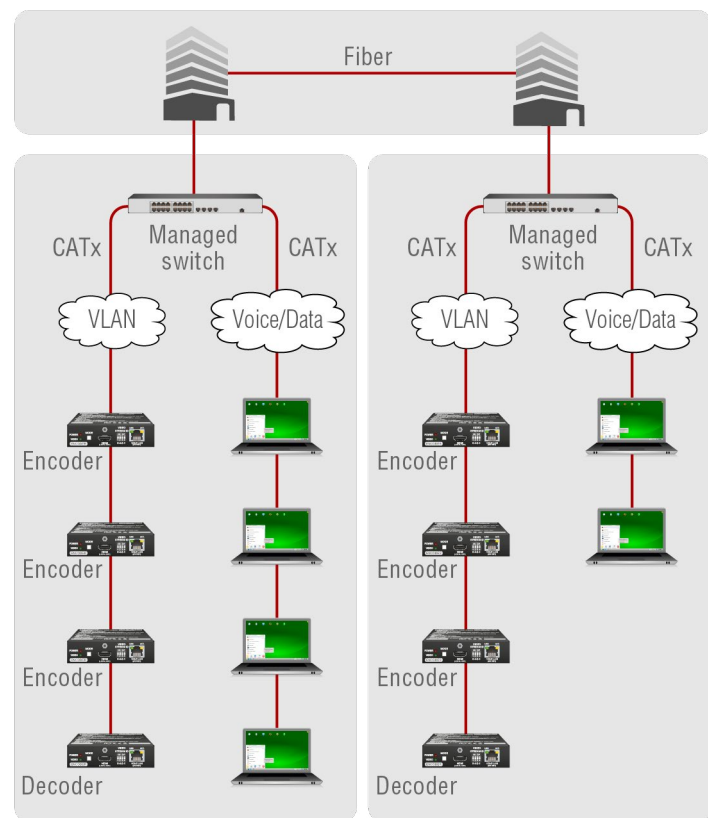

Hardware Requirement:

- 1 GbE Layer 3 (L3) switch or managed L2 switch

Why is it important?

By default, Lightware Video-over-IP Encoders and Decoders use multicast packet forwarding. The switches in the network shall offer the following capabilities:

- IGMPv2
- IGMP snooping
- IGMP fast leave
- IGMP Querier
- Multicast filtering
- 9k MTU - Jumbo/Giant frames

Switch Setup for Dante® Audio Signal Transmission

You can configure the QoS settings to ensure good system performance in a busy network. QoS (Quality of Service) refers to technology for prioritizing the transfer of specific data. By configuring the QoS settings recommended by Dante® on a network switch, you can prioritize the transfer of Dante® clock synchronization data and audio data over background data traffic. This will ensure good system performance when you need to transfer non-Dante® data over the same network. QoS is required when using Dante in networks that have 100Mbps devices, and is optional in networks with Gigabit devices. We recommend that QoS be enabled in all Dante® networks in order to ensure proper operation under all possible conditions.

The table below shows how Dante uses various Diffserv Code Points (DSCP) packet priority values: *

Priority	Usage	DSCP Label	Hex	Decimal	Binary
High	Time critical PTP events	CS7	0x38	56	111000
Medium	Audio, PTP	EF	0x2E	46	101110
Low	(reserved)	CS1	0x08	8	001000
None	Other traffic	BestEffort	0x00	0	000000

* source: <https://www.audinate.com/learning/faqs>

Green Ethernet in the Network

EEE (Energy Efficient Ethernet) is a technology that reduces switch power consumption during periods of low network traffic. It is also sometimes known as Green Ethernet and IEEE802.3az.

Although power management should be negotiated automatically in switches that support EEE, it is a relatively new technology, and some switches do not perform the negotiation properly. This may cause EEE to be enabled in Dante networks when it is not appropriate, resulting in poor synchronisation performance and occasional dropouts.

Managed Switch Properties in Details

IGMPv2

IGMPv2 is version 2 of the Internet Group Management Protocol. This protocol is used by end-point devices to signal their interest in receiving a specific multicast content via subscribing to the multicast group corresponding to the content. Using IGMPv2 packets, the end-point devices can send a leave message to indicate that they are no longer interested in receiving the stream of the multicast group. Moreover, a multicast capable router can periodically poll the end-point devices on its interfaces which multicast streams they are interested to receive. The answer to such a query is called a membership report. IGMPv2 must be supported by the managed switch.

IGMP Snooping

IGMP snooping is a feature which allows the switch to monitor IGMP traffic when enabled. The information collected from the IGMP packets is used by the managed switch to determine which interfaces the multicast traffic should be forwarded to. In other words, IGMP snooping is used to conserve bandwidth by allowing the switch to forward multicast traffic to those interfaces where it is really required.

IGMP Fast Leave

IGMP fast leave (or immediate leave), when configured, reduces the amount of time it takes for the managed switch to stop sending multicast traffic (corresponding to a multicast group defined by a multicast address) to an interface, where all end-point devices that used to be interested in a stream have sent a IGMP leave message. Without fast leave being enabled, the managed switch would first send out a query message and then would stop forwarding when no end-points answered within a pre-specified time interval. If fast leave is enabled, the switch stops forwarding the traffic without sending a query message.

IGMP Querier

In order for IGMP snooping to work properly, IGMP messages must traverse in the subnet between managed switches. However, if there is no multicast capable router present, periodically sending out query messages and receiving answers to those queries, IGMP messages are usually not forwarded upstream from one switch to another. By enabling the IGMP querier feature in a managed switch, the managed switch will act like a router, and will periodically query the devices in the subnet (even other managed switches) to send their membership reports. From those reports, all the listening switches with IGMP snooping enabled will be able to determine where multicast traffic should be sent to.

Multicast Filtering

Some control information from VINX devices is transmitted via multicast packets. However, these packets are not registered during certain startup intervals, or not registered at all. In order for all VINX devices in the subnet to receive such control information, multicast filtering must be set up, so that unregistered groups are forwarded to all interfaces on the managed switch.

Jumbo/Giant Frames

Ethernet frames consist of a header and a payload. Since the header has a fixed length (20 or 26 bytes), the bigger the payload, the higher the useful bandwidth is. Similarly, the higher the useful bandwidth, the better the picture quality of the encoded video stream will be. To maximize picture quality, the Ethernet frame size (and consequently, the payload) should be as high as possible. In a normal Ethernet frame, the payload can be at most 1500 bytes. An Ethernet jumbo frame, however, can carry up to 9000 bytes of payload. Since the goal of the transmission is to provide the best possible picture quality in all circumstances, the VINX Encoder device produces Ethernet jumbo frames. Thus, the handling of jumbo frames has to be enabled in the managed switches.

10.11. Hashtag Keyword List

This user's manual contains keywords with hashtag (#) to help you find the relevant information as quick as possible.

The format of the keywords is the following:

#<keyword>

The usage of the keywords: use the **Search** function (Ctrl+F / Cmd+F) of your PDF reader application, type the # (hashtag) character and the wished keyword.

The **#new** special keyword indicates a new feature/function that has just appeared in the latest firmware or software version.

Example

#dhcp

This keyword is placed at the DHCP (dynamic IP address) setting in the front panel operation, the Lightware Device Controller (LDC) and the LW3 programmer's reference section.

The following list contains all hashtag keywords placed in the document with a short description belonging to them. The list is in **alphabetical order** by the hashtag keywords.

Hashtag keyword ↓↑	Description
#advancedview	Advanced view window
#analogaudio	Analog audio related settings
#audio	Audio related settings
#bandwidth	Video stream bandwidth settings
#button	Description of the front panel buttons
#compression	Video compression settings
#crosspoint	Crosspoint switch setting
#dante	Dante® audio related settings
#devicelabel	Device label
#dhcp	Dynamic IP address (DHCP) setting
#dipswitch	Description of the front panel DIP switches
#edid	EDID related settings
#factory	Factory default settings
#firmwareversion	Firmware version query
#flip	Picture rotation/flip setting
#framedetector	Frame detector in LDC/built-in web
#hdcp	HDCP-encryption related setting
#inputselection	Video input selection for VINX-210AP-HDMI-ENC model
#ipaddress	IP address related settings
#kvm	USB KVM related settings

Hashtag keyword ↓↑	Description
#label	Device label
#led	Description of the front panel LEDs
#login	Cleartext login feature
#multicast	Multicast mode setting
#mute	Mute/unmute (for analog audio) setting
#network	Network (IP address) related settings
#new	New feature/function of the product
#osd	OSD settings
#qualitymode	Video quality mode setting
#reboot	Restarting the device
#reset	Restarting the device
#resolution	Resolution of the video signal query
#restart	Restarting the device
#rotation	Picture rotation/flip setting
#rs232	RS-232 related settings
#rs-232	RS-232 related settings
#scaler	Scaler related settings
#serial	RS-232 related settings
#signaltype	Signal type (HDMI/DVI) setting
#source	Video source selection
#status	Status query
#streamid	Video Stream ID settings
#switch	Crosspoint switch setting
#terminal	Advanced view window
#unicast	Unicast mode setting
#unmute	Mute/unmute (for analog audio) setting
#usbkvm	USB KVM related settings
#videoquality	Video quality mode setting
#videostreamid	Video Stream ID settings
#videowall	Videowall related settings
#volume	Volume (for analog audio) setting

10.12. Applied Ports (Network Settings)

The following ports are necessary to pass via a network switch/firewall for a proper working between the device and the softwares:

Purpose/function	Affected software	Protocol	Port nr.
Firmware update TFTP	LDU2	UDP	69
		UDP	49990
		UDP	49995
Device Discovery	LDC	UDP	224.0.0.251:5353
Remote IP	LDC	UDP	230.76.87.82:37421
LW3 protocol	-	TCP	6107
HTTP port	-	TCP	80
RS-232 command injection	-	TCP	6752

10.13. Audio Port Numbering

VINX-210AP-HDMI-ENC

	Video port	Audio port
HDMI in	I1	I1
VGA in	I2	-
Analog in	-	I2
Analog out	-	O1

VINX-120AP-HDMI-ENC and VINX-120AP-HDMI-ENC-DNT

	Video port	Audio port
HDMI in	I1	I1
Analog in	-	I2
Analog out	-	O1

VINX-110AP-HDMI-DEC

	Video port	Audio port
HDMI out	O1	O1
Microphone in	-	I2
Analog out	-	O2

10.14. Further Information

Limited Warranty Statement

1. Lightware Visual Engineering PLC (Lightware) warrants to all trade and end user customers that any Lightware product purchased will be free from manufacturing defects in both material and workmanship for three (3) years from purchase unless stated otherwise below. The warranty period will begin on the latest possible date where proof of purchase/delivery can be provided by the customer. In the event that no proof can be provided (empty 'Date of purchase' field or a copy of invoice), the warranty period will begin from the point of delivery from Lightware.

1.1. 25G and MODEX product series will be subject to a seven (7) year warranty period under the same terms as outlined in this document.

1.2. If during the first three (3) months of purchase, the customer is unhappy with any aspect of a Lightware product, Lightware will accept a return for full credit.

1.3. Any product that fails in the first six (6) months of the warranty period will automatically be eligible for replacement and advanced replacement where available. Any replacements provided will be warranted for the remainder of the original unit's warranty period.

1.4. Product failures from six (6) months to the end of the warranty period will either be repaired or replaced at the discretion of Lightware. If Lightware chooses to replace the product, then the replacement will be warranted for the remainder of the original unit's warranty period.

2. The above-stated warranty and procedures will not apply to any product that has been:

2.1. Modified, repaired or altered by anyone other than a certified Lightware engineer unless expressly agreed beforehand.

2.2. Used in any application other than that for which it was intended.

2.3. Subjected to any mechanical or electrical abuse or accidental damage.

2.4. Any costs incurred for repair/replacement of goods that fall into the above categories (2.1., 2.2., 2.3.) will be borne by the customer at a pre-agreed figure.

3. All products to be returned to Lightware require a return material authorization number (RMA) prior to shipment, and this number must be clearly marked on the box. If an RMA number is not obtained or is not clearly marked on the box, Lightware will refuse the shipment.

3.1. The customer will be responsible for in-bound and Lightware will be responsible for out-bound shipping costs.

3.2. Newly repaired or replaced products will be warranted to the end of the originally purchased product's warranty period.

Document Revision History

Rev.	Release date	Changes	Editor
1.0	21-12-2017	Initial release.	Laszlo Zsedenyi
...			
2.7	06-10-2022	Minor changes for HTML export	Laszlo Zsedenyi
2.8	19-12-2022	Function change on WP-VINX reset button; minor corrections	Tamas Forgacs

Contact Us

sales@lightware.com

+36 1 255 3800

support@lightware.com

+36 1 255 3810

Lightware Visual Engineering PLC.

Peterdy 15, Budapest H-1071, Hungary

www.lightware.com

©2022 Lightware Visual Engineering. All rights reserved. All trademarks mentioned are the property of their respective owners. Specifications subject to change without notice.